

SRF CHALLENGES FOR ENERGY RECOVERY LINACS

A. Burrill[#], Helmholtz Zentrum Berlin, Berlin, Germany

Abstract

Many of the challenges associated with operating a Superconducting RF (SRF) Energy Recovery Linac (ERL) are independent of the choice of operating frequency, beam energy, and overall purpose of the machine. Worldwide there are an increasing number of ERLs in various stages of development and operation which are facing a number of similar challenges and often solving them in very different ways. This paper will seek to summarize the main challenges the community as a whole faces, address how different laboratories are working to solve these problems, and seek to identify areas of overlap where the community can work together to solve some of these common problems.

INTRODUCTION

The development of Energy Recovery Linacs (ERLs) over the past 10 years has grown at an impressive rate. There are currently 10 institutions pursuing the development of SRF ERLs with 2 institutions actively operating ERLs as light sources, and for basic R&D. The reason for the rapid expansion of ERL development is centered on the energy recovery process and what this means to the operational cost and feasibility of running a low-emittance, high-current light source, photo-fission

driver, electron-nucleon collider or small electron scattering experiment [1-4].

For the ERL operation there are two distinct sections of the machine, the electron source (photoinjector) and booster module comprise the first section with the linac module making up the second section. Figure 1 shows a schematic of the HZB BERLinPro ERL and these two distinct sections [1]. In the photoinjector and booster there is no energy recovery processes, so the cavities are heavily beam loaded and require a significant amount of RF power to accelerate the electrons, on the order of 200 kW per cavity in the case of the BERLinPro project which will operate with a 100 mA average beam current.

On the other hand, once the electrons reach the linac the energy recovery process takes place and the power required to drive the linac cavities is on the order of 10 kW or less. This is due to the fact that as the electron bunch enters the linac it is accelerated on the crest of the RF wave, and when it returns, after making a pass around the ring, it is decelerated on the trough of the RF wave, returning the power to the cavity. Hence there is effectively zero net beam loading if done correctly and therefore allows for operation with much lower RF input power, and thus reduced operating cost.

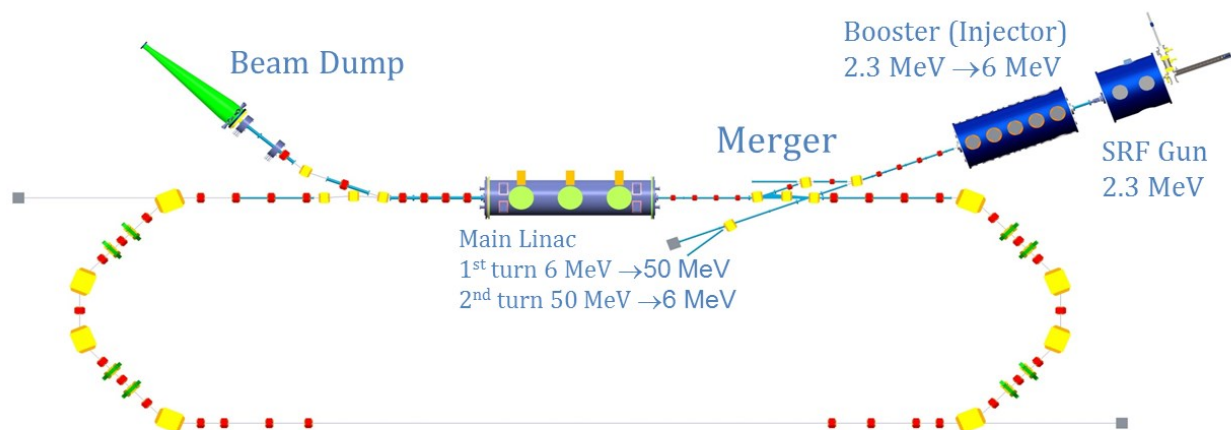

Figure 1: The layout of the BERLinPro ERL showing the main components of a superconducting RF ERL. On the top right are the injector and booster sections, which do not benefit from the energy recovery process. While in the middle top is the linac cryomodule which does utilize the energy recover process to accelerate and then decelerate the electron beam.

In addition there is no high energy, 100 mA, electron beam that must be disposed of after it is used.

The challenges presented by the construction of these machines come from all different areas of technological development, and this paper will seek to address them by looking at the following main issues:

1. The cavity design
2. The higher order mode damper design and operation
3. The stable RF operation and control of microphonics
4. The cryomodule design

There are certain challenges that are more specific to the different cryomodules required for the ERL, and these will be addressed in sections below. This paper will also try to summarize the latest developments in the area mentioned above.

CAVITY DESIGN

The cavity design that is required for the ERL differs from that of other electron accelerators in large part due to the high average beam currents at which these new machines are being designed to operate. Table 1 provides a summary of the ERLs that are currently under design,

construction or operation. From this table it is clear that an operating current of 10-100 mA or greater is desired for most machines. The 100 mA average current, which many machines will seek to reach either initially or during upgrade phases places great, but very different demands on all of the SRF cavities that make up an SRF ERL.

SRF Photoinjectors

The specific challenges associated with an SRF ERL photoinjector, such as that is being developed at HZB, and BNL [5, 6] are related to the fact that the photoinjectors are designed to operate at a very high electric field, $E_{peak} = 40 - 60$ MV/m, while coupling in several hundred kilowatts of RF power and utilizing a normal conducting photocathode as the electron source. In addition these cavities are not true $\beta=1$ electron accelerating structures since the electrons are created in this cavity and thus undergo acceleration from their nascent state, thus further complicating the design. In addition since each of these SRF photoinjectors is usually a unique design, the benefits gained from fabrication of a large number of identical cavities does not exist, thus making the photoinjector development that much more exciting and challenging, but also costly.

Table 1: A list of the existing ERLs around the world. The status of the machine is given in the right hand column.

Location	Purpose	Current	Energy	Status
SINAP (China)	THz FEL	20 mA	20 MeV	Prototype
BNL (USA)	high current R&D/eRHIC	50-300 mA	20 MeV	Commissioning
Daresbury (UK)	FEL (IR), THz, Demo	13 mA	27.5 MeV	Operational
PKU (China)	FEL	1 mA	30 MeV	Prototype
IHEP (China)	ERL & FEL	10 mA	35 MeV	Design Phase
KEK (Japan)	cERL/ light source	10-100 mA	35 MeV/3 GeV	Commissioning
TRIUMP (Canada)	Photo-fission driver	10 mA	50 MeV	Construction
HZB (Germany)	R&D for future light source	100 mA	50 MeV	Construction
Mainz (Germany)	Electron scattering experiments	1-10 mA	100 MeV	Design Phase
JLab (USA)	FEL (IR, UV) THz	10 mA	200 MeV	Operational
Cornell (USA)	X-ray light source	100 mA	5 GeV	Prototype
CERN (Switzerland)	LHeC (EIC)	6.4 mA	60 GeV	Design Phase

The main challenges for the SRF photoinjectors are summarized in table 2, with a sectional view of the HZB photoinjector given in figure 2. In this figure the challenge associated with these photoinjectors is easier to visualize. The cavity cell shape is complicated and requires a great deal of machining to fabricate the cell components as well as the cathode insertion device. As only one cavity is being fabricated, this adds to the challenge of the fabricated cavity matching the RF design exactly. It can also be seen that the chemical processing and high pressure water rinsing of the cavity becomes more complicated than for a traditional elliptical SRF cavity due to the complicated geometry near the cathode stalk and RF choke cell shown on the right hand side of the image.

Table 2: A summary of the requirements and challenges for a SRF Photoinjector for an ERL

Requirement	Challenge
2.3 MeV 100 mA beam = 230 kW RF power	- Dual High power RF power couplers (115 kW each)
Loaded Q (10^4 - 10^7)	- Coupler Penetration into beam pipe leading to coupler kicks of the soft beam, possible interception of beam halo. - Power dissipation in coupler region - gasket heating
Multiple beam operating conditions - Bunched operation - High current mode - High charge mode	- Variable coupling - LLRF control, - cavity stability
Superconducting magnet near the cavity	-Magnetic Shielding -Quench recovery
Normal conducting cathode in SRF cavity	-Thermal isolation - Cathode cooling -Multipacting -Contamination

SRF Booster Cavities

The cavity required for the booster module is often a single or two cell cavity as this represents the best compromise between beam loading and the accelerating voltage per cavity [7, 8]. These cavities require very strong RF coupling, since the beam loading is heavy, again on the order of 200 kW per cavity for a 100 mA beam.

This presents challenges less so for the cavity design itself, as this is an elliptical accelerating structure, where the reduced number of cells reduces the complexity, but instead moves the challenges to the RF input couplers as well as the HOM damper design. Recent experiences from KEK have shown that management of the power dissipation in the HOM antennas is a critical design issue which can limit the overall performance of the cryomodule, even at low accelerating gradients in the cavity on the order of 5 MV/m[9].

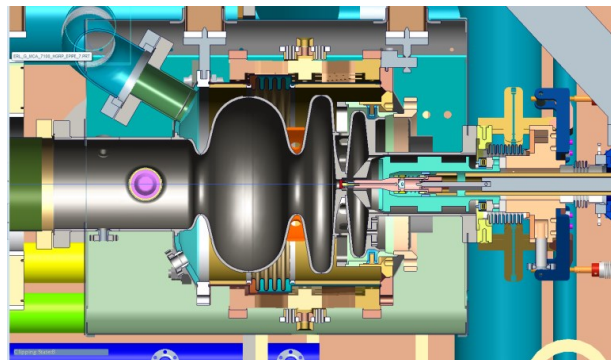

Figure 2: A cross sectional view of the BERLinPro SRF injector. The design of the cathode insert is based on the HZDR SRF photoinjector design [10].

Fortunately a modification to the HOM coupler design and the antenna ceramic will allow for this problem to be overcome, however it illustrates the problems that can arise with new designs for such high beam current. Alternatively, ferrite/ceramic based beam tube HOM couplers are being pursued by Cornell, BNL and HZB among others, which do not suffer from the KEK problems but do pose a significant danger of dust contamination and charging issues, more of which is discussed below.

SRF Linac Cavities

The main accelerating linac has design criteria that are somewhat different from those of the photoinjector and booster cavities. For an ERL, the linac cavity is typically a 5-9 cell cavity operating between 700 MHz and 1.5 GHz. The choice in the number of cells depends on the current for which the cavity is being designed as well as how well the HOMs are able to be coupled out of the structure, something that depends on the design and operating frequency. The choice of optimum frequency is a complicated matter that is related to the design operating current of the machine, the charge per bunch, bunch pulse length and the HOM power extraction required. Regardless of the chosen operating frequency and temperature there are several parameters which remain general design goals. In general the linac cavity must satisfy the following conditions:

1. Maintain a high Q_0 at the operating gradient, which is typically agreed to be between 15 and 20 MV/m.

2. Maintain a good emittance for a reasonable charge per bunch, typically 100 pC/ bunch for a 1300 MHz RF cavity.
3. The design should strive to reduce the E_{peak}/E_{acc} ratio as this has a direct relationship to field emission in the cavity, something which is detrimental to high Q_0 operation.
4. The design must provide good HOM propagation to allow for the higher order mode power to be absorbed beyond the cavity itself. In addition the cavity should be designed to avoid trapping any dangerous HOMs inside the cavity as this can potentially lead to beam instabilities.
5. The cavity should be designed for a minimum df/dp ratio so that pressure fluctuations do not disrupt the operation of the narrow-bandwidth linac cavities.
6. The sensitivity to microphonics should also be minimized in the cavity design to allow for operation with as high a loaded Q as possible, thus reducing the required RF power to drive the cavity.

Recent results from Cornell have demonstrated that this list of parameters can be satisfied in the vertical and horizontal test cryostat for a 7 cell ERL linac cavity, albeit without beam [11].

HIGHER ORDER MODE DAMPERS

As mentioned previously, the higher order modes excited in the cavities, the linac in particular, require suitable damping in order to avoid beam break-up instabilities or unwanted heating of the SRF cavity. For a 7 cell linac cavity with an HOM loss factor of $k_{HOM} = 12$ V/pC, a charge of 77 pC, and a 100 mA average current it is possible to produce 200 W of HOM power in each cavity based on equation 1.

$$P_{HOM} = k_{HOM} \cdot q_{bunch} \cdot I_{beam} \quad (1)$$

As this amount of power must be removed from the cavity in order to maintain operations an adequate HOM design is required. There are currently three general different design philosophies for HOM damping in SRF ERL cavities. The first two damper designs both make use of a broadband RF absorbing material, typically ferrite, SiC or AlN. In the first design the absorber is placed in a section of waveguide off of the cavity beam pipe, as shown in figure 3. In the second design the absorber is placed adjacent to the cavity along the beam pipe length. A picture of the beamline HOM absorber from BNL is shown in figure 4.

This type of absorber has several advantages, namely the broadband RF absorbing properties, the high power levels at which they can operate, and the ability to fabricate the material in the shape that best suits the application.

The waveguide absorbers also have the benefit of being further removed from the SRF cavity while not occupying much additional space along the length of the cryomodule, thus helping maintain a high real estate gradient, a key parameter for machine design. The downside of these types of absorbers is that they are not particulate free, so any dust from the absorber material can be detrimental to the cavity performance and the desire to maintain a high Q_0 .

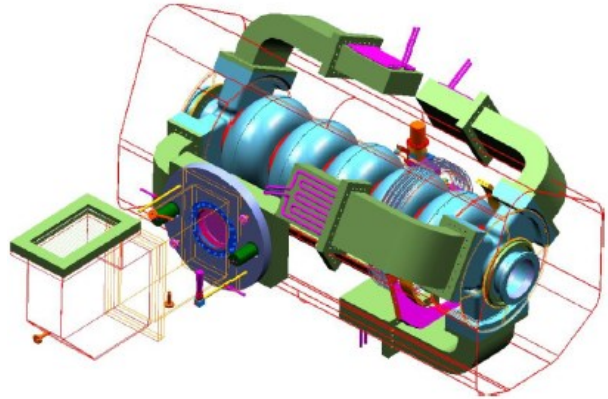

Figure 3: The JLab 750 MHz SRF cavity which utilizes 6 waveguide HOM absorbers.

This is perhaps more important for the beamline absorber which resides adjacent to the cavity due to its close proximity and direct line of sight to the cavity itself. In addition there have been issues in the past with the ferrite absorbers becoming insulating at 80K, their design operating temperature when used in the beamline configuration. This has led to serious problem with beam instabilities [12, 13]. Furthermore, care must be exercised when cooling the absorber to 80K as cooling down too quickly can result in cracking the ferrite material, thus increasing the likelihood of contamination of the SRF cavity.

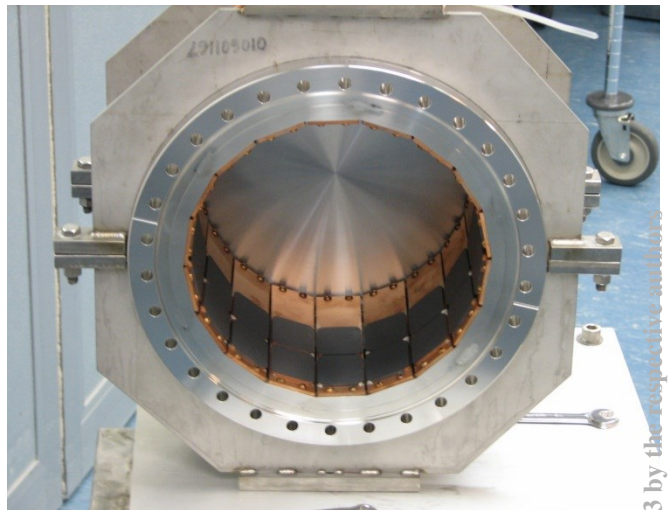

Figure 4: The BNL beamline HOM absorber used in the BNL ERL.

The other type of HOM damper that is being employed is a RF antenna design. This is currently being used at KEK on the booster module as well as at BNL on the new BNL3 cavity design [7, 14]. This design is, to first order, a high pass filter. A notch is set to prevent the fundamental mode from being absorbed by the filter, while the higher order modes couple well to the antenna. The design of both the KEK and BNL HOM antenna is shown in figure 5 for reference.

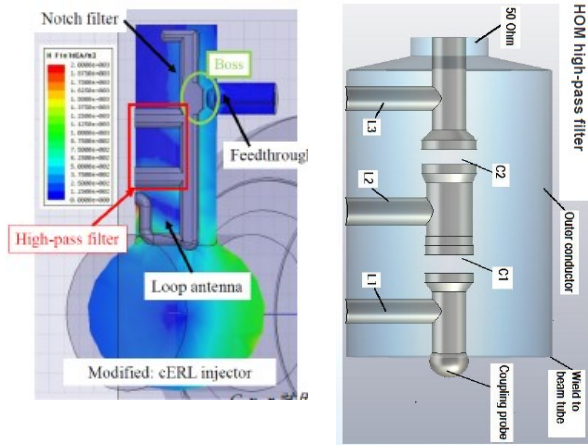

Figure 5: The KEK (left) and BNL (right) HOM antennas for ERL applications.

This configuration has the benefit of utilizing very little space, thus helping maintain a high real estate gradient, as well as being a particulate free design, and thus compatible with the SRF cavity. The downside of this type of coupler is the difficulty to adequately cool the superconducting HOM antenna to avoid run-away heating issues, as previously mentioned.

RF STABILITY

For the SRF linac cavity, which sees zero net beam loading, the amount of RF power required to operate the cavity is primarily determined by how well much the cavity is detuned due to external noise sources. The microphonics instability from external sources as well as the mechanical design play a large role in determining both the external coupling factor required for the cavity, Q_L , and in turn the amount of RF power required for the cavity to operate in a stable manner. For the ERL an amplitude phase stability, σ_A/A , of better than 1×10^{-4} and a phase stability, σ_ϕ of better than 0.02° is required in order to operate with $Q_L > 1 \times 10^8$. This performance was demonstrated at HoBiCaT with a TESLA 9-cell cavity by HZB and Cornell utilizing the Cornell LLRF system. [15] The cavity was operated with a Q_L of 2×10^8 which corresponds to a cavity half bandwidth of 3.4 Hz and was stable with peak microphonics of 30 Hz [16]. By being able to operate the main linac cavities with a high Q_L significant cost savings can be realized in both the capital procurement of RF transmitters and power couplers as well as in the operational cost of running the RF system. Recent tests at Cornell have demonstrated the ability to

utilize a 5kW solid state amplifier for operation of an ERL linac cavity [16].

CRYOMODULE

The cryomodule design requires the integration of the SRF cavity into a helium vessel nested inside of magnetic shielding along with high power input couplers, HOM absorbers, beam diagnostics and the associated cryogenic systems. The system must be designed such that precise alignment of the cavity beam axis is maintained, thus helping reduce the chance of emittance dilution in the module. In addition, all of the external heat loads must be well intercepted prior to reaching the 2K circuit to allow for the best operational performance of the module as previously mentioned.

The greatest challenge in building the cryomodule is ensuring that the cavity performance, as measured in vertical RF tests, is not degraded or compromised by any item in the cryomodule. Very often the assembly process itself is the biggest culprit resulting in early onset field emission, and thus degraded cavity performance, many times limiting the maximum achievable gradient due to the increased cryogenic load. In addition, HOM loads, input couplers and cold magnets placed inside the cryomodule can also adversely affect the performance.

However, HZB has been analysing mechanisms that deteriorate the Q-factor in cryomodule operation. In 2009 HZB demonstrated that the performance of SRF cavities could actually be improved by carefully controlling the cool down through the transition temperature to avoid thermal gradients [17]. More recent results support the hypothesis that temperature gradients cause thermocurrents which in turn result in additional trapped flux as the cavity goes superconducting. Hence cavity quality factor can be improved significantly if the cavity is cycled a little above the transition and then cooled down again. In these experiments at HZB the residual resistance of the cavity was reduced by a factor of 2.5 through the use of thermal cycling [18-20]. Cornell University has also adopted this technique and has recently measured Q_0 values for a 7 cell 1300 MHz cavity in excess of 6×10^{10} at an operating gradient of 16.2 MV/m, the design gradient for the Cornell ERL [11].

CONCLUSIONS

The number of laboratories working on development of SRF Energy Recovery Linacs is at an all-time high. Great advances are being made in the fields of cavity design, RF control, HOM damper development and cryomodule performance optimization. The efforts of many contributors over the past decades is making the development of a high Q_0 , high gradient ERL a reality around the world. While there are many challenges to face, the current state of cavity design, testing and cryomodule assembly is encouraging, and for laboratories entering the field there is much to be learned and great opportunities to collaborate in the development of next generation Energy Recovery Linacs.

REFERENCES

- [1] J. Knobloch, et al., ICFA Newsletter, 58 p. 118 (2012).
- [2] R. Heine, et al., IPAC'12, New Orleans, Louisiana, USA, p. 188 (2012).
- [3] S. Koscielniak, et al., LINAC2012, Tel-Aviv, Israel, p. 729 (2012).
- [4] F. Zimmermann, LINAC2012, Tel-Aviv, Israel, p. 797 (2012).
- [5] A. Neumann, et al., MOPFI003, These Proceedings, p. (2013).
- [6] W. Xu, et al., IPAC'13, Shanghai, China, p. 2492 (2013).
- [7] E. Kako, et al., IPAC'12, New Orleans, Louisiana, USA, p. 2239 (2012)
- [8] M. Liepe, et al., EPAC'08, Genoa, Italy, p. 883 (2008).
- [9] E. Kako, TTC Workshop Cornell, p. (2013).
- [10] A. Arnold, et al., NIM:A, 577 p. 440 (2007).
- [11] N. Valles, et al., IPAC'13, Shanghai, China, p. 2459 (2013).
- [12] M. Liepe, et al., LINAC2010, Tsukuba, Japan, p. 382 (2010).
- [13] E. Chojnacki, et al., SRF'09, Berlin, Germany, p. 643 (2009).
- [14] W. Xu, et al., IPAC'12, New Orleans, Louisiana, USA, p. 2486 (2012).
- [15] A. Neumann, et al., SRF'11, Chicago, IL USA, p. (2011).
- [16] M. Liepe, TTC Workshop Cornell, p. (2013).
- [17] O. Kugeler, et al., SRF'09, Berlin, Germany, p. 352 (2009).
- [18] O. Kugeler, et al., IPAC'13, Shanghai, China, p. 69 (2013).
- [19] O. Kugeler, et al., These proceedings, p. (2013)
- [20] J. Vogt, et al., accepted for publication in PRST-AB, p. (2013).