

LORENTZ FORCE DETUNING SIMULATIONS OF SPOKE CAVITIES WITH DIFFERENT STIFFENING ELEMENTS

J. L. Munoz, ESS-Bilbao, Bilbao, Spain

F. J. Bermejo, Instituto de Estructura de la Materia, CSIC, Madrid, Spain

Abstract

Lorentz force detuning caused by radiation pressure on the Niobium cavity walls is of concern in cavity design and operation since its magnitude can approach the cavity bandwidth. This effect can be reduced using passive stiffening elements in the cavity. In this work, Lorentz force detuning has been studied by numerical simulations for spoke cavities. Different stiffening elements have been considered. Static and dynamic behaviour have been analysed by means of 3D static and transient coupled electromagnetic and mechanical finite elements simulations.

INTRODUCTION

The pulsed RF power induces cyclic Lorentz forces on the cavity surface proportional to the surface magnetic and electric fields. The induced Lorentz force levels are small but will mechanically excite deformations in the cavity walls that modify slightly the resonant frequency (detuning) [1–5]. This detuning is also very small in magnitude, but due to the high quality factor of the superconducting cavity it can leave the cavity out of resonance. The tuning strategies to compensate this effect contribute to the total power budget of the cavity operation. In this work the Lorentz force detuning is studied by means of numerical finite element calculations for a double spoke cavity. The coupling of electromagnetic and mechanical simulations (steady and transient states) provides insight in the effect and contributes to validate the mechanical stiffening elements designed for the cavity.

CAVITY CHARACTERISTICS

The cavity used for the Lorentz force detuning simulations has been the double spoke resonator designed for ESS-Bilbao linac [6]. This cavity is equivalent for the ones to be used for the ESS project. The cavity is designed for $\beta = 0.50$ and incorporates a 100 mm RF coupler port and three other 56 mm ports for several uses. Beam tube aperture is fixed also to 56 mm. Cavity walls have a thickness of 4 mm. The stiffening elements included in this study are donut-like ribs in the cavity covers and stiffeners connecting the beam pipe with the cavity covers (see Fig 1).

LORENTZ FORCE DETUNING

RF power produces a pressure on the cavity walls. This pressure is a function of the electric and magnetic fields at the surface, according to the expression

$$P_{rad} = \frac{1}{4}(\epsilon_0 \mathbf{E}^2 - \mu_0 \mathbf{H}^2) \quad (1)$$

This pressure deforms the cavity walls, changing slightly the resonant frequency. For a spoke cavity, and in general for all cavities, the deformation results in a reduction of resonant frequency. The frequency shift is found to be proportional to the second power of the accelerating field ($\Delta f \propto K_L E_{acc}^2$) and the proportionality factor K_L is the Lorentz force detuning coefficient. This frequency shift is usually small (tens of Hertz at the usual powers) but due to the very high quality factor of superconducting cavities can result in an important detuning that must be compensated by mechanical tuners. In order to reduce the mechanical induced detuning effects, stiffening elements are added to the cavity design.

SIMULATION PROCEDURE

One half of the cavity is used in the simulations, to take advantage of the symmetry but keeping all the ports and openings that can affect the result (see Fig. 2). The average mesh quality had about 600 ktets for the vacuum region (RF calculations) and about 700 ktets for the solid domain (the Nb cavity). The mechanical characteristics of the Nb were constant, with values $E = 107 \cdot 10^9 Pa$, $\nu = 0.359$ and density $\rho = 8560 kg/m^3$.

As a first step an electromagnetic eigenfrequency solution is obtained, and the radiation pressure is computed using expression 1. In order to scale the electric and magnetic field values to the operating ones, a gain factor is defined using the accelerating field as scale. The accelerating field is defined as

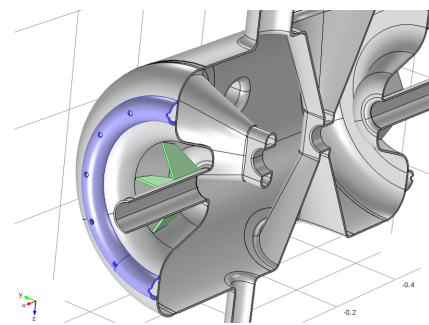

Figure 1: One half of the geometry of the cavity showing the stiffening elements added to the body, "donut-like" ribs (in blue) and stiffeners connecting the beam pipe with the cover (red).

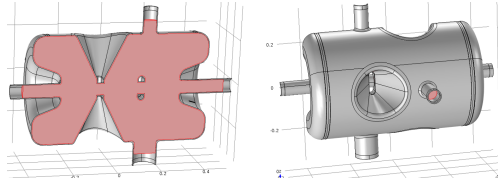

Figure 2: Geometry of the studied double spoke cavity, showing the half cavity and inside vacuum from the symmetry plane (left) and from the side view (right).

$$E'_{acc} = \frac{V_{acc}}{L_{acc}} = \frac{\int E_z(z) \cos\left(\frac{\omega z}{\beta c}\right) dz}{\frac{3}{2}\beta\lambda} \quad (2)$$

In equation 2 the effective voltage is computed assuming a constant particle velocity βc and with the cavity centred at $z = 0$. For a certain power input in the cavity, the accelerating field will be the one defined in Eqn. 2 multiplied by a certain gain factor. This same factor is also introduced to scale the fields in Eqn. 1, so an adequate relation between P_{rad} and E_{acc} is obtained. The distribution of the radiation pressure in cavity surface is depicted in Fig. 3. It is clear that the maximum value is obtained in the cavity ends near the beam pipe region, so this part of the cavity should be the most susceptible to deformation and, thus, where the stiffening elements should be installed.

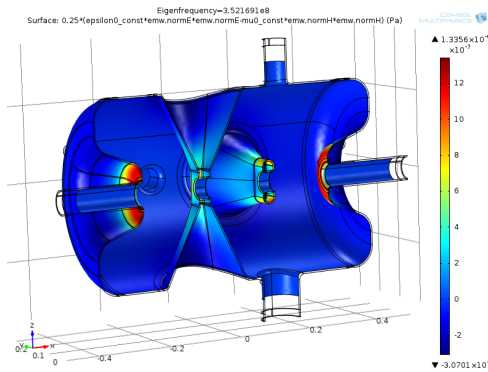

Figure 3: Distribution of radiation pressure in the cavity surface. The magnitude of the pressure must be corrected with an adequate gain to reach the corresponding accelerating field value required.

The obtained radiation pressure is applied to a mechanical simulation model as an internal pressure on the cavity wall. Additionally, the cavity in the mechanical model has an external pressure of 0.16 MPa simulating the He in the jacket. Fixed boundary conditions are applied in both beam pipes and in all the flanges of the cavity. The mechanical model is coupled to a deformed mesh model for the inside cavity vacuum. Finally, another electromagnetic eigenfrequency simulation is performed on the deformed vacuum region, obtaining the final value of the frequency. Changing the value of the gain factor the frequency shift vs E_{acc}

07 Cavity design

O. Cavity Design - Accelerating cavities

is obtained. All simulations are done using COMSOL Multiphysics software [7].

For transient simulations the procedure is more complex. The pulse temporal profile is introduced as gain factor profile, and a fully transient mechanical simulation is run. For each time step the deformed mesh field (deformation of the inside vacuum region) is exported to an external file, and electromagnetic eigenfrequency simulation are run afterwards on these data files.

STATIC (CW) BEHAVIOUR

A first simulation with the cavity without stiffening elements was done. The result (for a power input corresponding to a low accelerating field of $E_{acc} = 0.18 \text{ MV/m}$) can be seen in Fig. 4. Simulations with the cavity with different stiffening elements have been performed. In Fig. 5 the dependence of cavity frequency with the square of accelerating field is shown for the four cases considered (without stiffening elements, with donut-ribs, with pipe stiffeners and with both types of stiffening elements). The initial frequency for $E_{acc} = 0$ is different for each case as a result of the different stiffness against the external Helium pressure. Lorentz detuning factors as previously defined are summarised in table 1. The effect of the stiffening elements is greater than the achieved, for example, by thermal spraying [8].

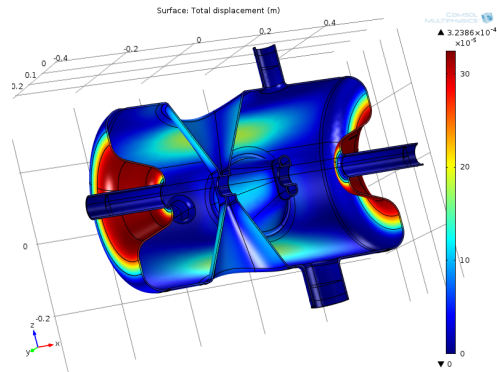

Figure 4: Deformation field for a cavity with no stiffening elements, for an input power corresponding to $E_{acc} = 0.18 \text{ MV/m}$.

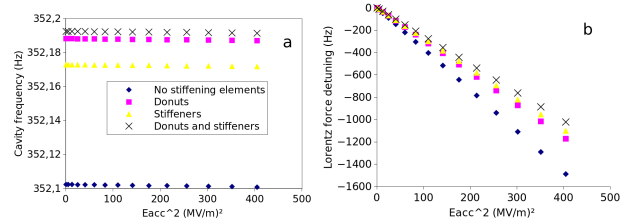

Figure 5: Lorentz force detuning of the spoke cavity in stationary condition, for different mechanical stiffeners incorporated. The absolute (a) and relative (b) changes of frequency are represented.

Table 1: Computed Lorentz Force Detuning Factors

Stiffening Element	Detuning Factor (kHz/(MV/m))
No stiffeners	-0.00368
Donuts	-0,00289
Stiffeners	-0,002718
Donuts and stiffeners	-0,00252

PULSED BEHAVIOUR

In pulsed operation the RF power is applied to and removed from the cavity in a cyclic way. During the time duration of the pulse, the cavity starts to deform, and a complex dynamic behaviour is set by the excitation of different mechanical modes of the cavity. If the pulse is long enough, eventually the deformation will reach the steady state as described in the previous section. But the power pulse can finish before this happens. After the pulse has finished, the excited mechanical modes can continue to be activated until their energy is finally dissipated and the cavity reaches again a steady state. The external He pressure (established at 0.16 MPa) will also excite dynamically the cavity if it is included in the transient simulations. The deformation induced is much greater than the produced by the Lorentz force, so to eliminate its influence on the studies a very time consuming computation had to be done until the steady state is reached. The result obtained with such a simulation is shown in Fig 6. After about 10 ms the cavity continue to oscillate. To avoid this situation, the chosen strategy has been to perform first a mechanical steady state simulation with the He pressure, and afterwards the time dependent one including the radiation pressure.

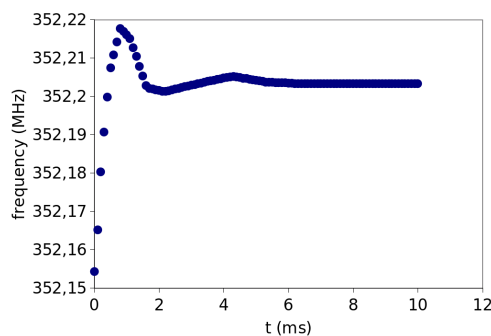

Figure 6: Transient deformation induced detuning of the spoke cavity. The cavity starts at its no-load geometry and then a static external load of 0.16 MPa is applied at initial time. After about 10 ms the oscillations have been reduced.

The onset of the RF power is studied in Fig. 7. A constant power (corresponding to an accelerating field of $E_{acc} = 10 \text{ MV/m}$) is applied at time $t = 0$, and the deformation of a cavity probe point in the surface is monitored. The deformation of the point (in the area of maximum deformation near the beam pipe) oscillates due to the excitation of a mechanical mode. This mode, with deformation

of the cavity ends, for this cavity has an eigenfrequency of about 336 Hz ([6]). For the cavity without any stiffening element (blue line in Fig. 7) the oscillation remains active after the 10 ms of computed time, so RF pulses of this and shorter times will not reach a steady state during the pulse. For the case with a cavity including all stiffening elements (red line in Fig. 7), the oscillations are quickly damped.

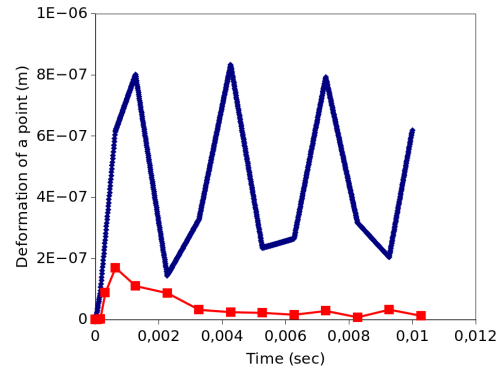

Figure 7: Deformation of a selected point under a constant RF power. The deformation oscillates due to the excitation of the mechanical modes. The blue line corresponds to a cavity without stiffening elements while the red one includes all the stiffening elements considered.

The RF pulse profile simulated is shown in figure 8. Starting at a time of 10 ms a pulse of duration $T_{pulse} = 2 \text{ ms}$ is applied. The power rises from zero to the maximum level in a time $T_{fill} = 0.1 \text{ ms}$. After the pulse duration the level falls exponentially to zero with a time constant $\tau = 10^{-4} \text{ secs}$. The power pulse power corresponds to an accelerating gradient of 10 MV/m .

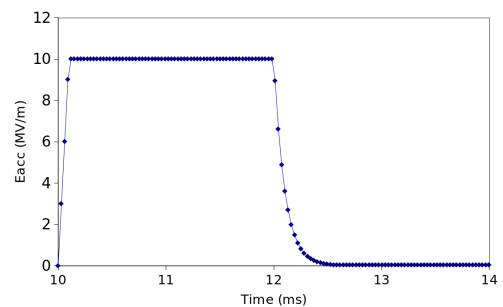

Figure 8: Profile of an RF pulse used in this study studied. At the pulse starting time, the power rises linearly during time T_{fill} until it reaches the pulse power. After the pulse time T_{pulse} has passed, the power falls exponentially to zero with a time factor τ_0 .

The frequency of cavity computed for the four different cases considered can be seen in Fig. 9 for a pulse like the one described. For the case without stiffening elements the change in frequency is quite high and the oscillations remain after the pulse has ended. With stiffening elements added to the cavity the frequency change is reduced to the

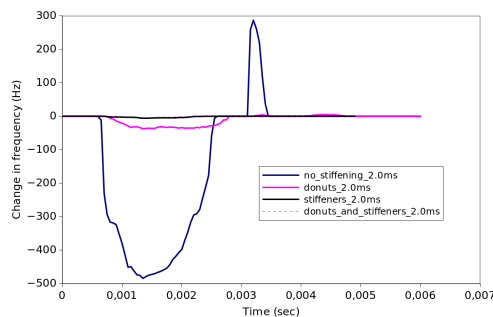

Figure 9: Frequency of the cavity for the four cases considered in a fully transient simulation in a power pulse of duration 2 *ms*.

order of Hz during the pulse.

CONCLUSIONS

The Lorentz force detuning has been studied for a double spoke cavity by means of coupled electromagnetic and mechanical finite element calculations. Different stiffening elements in the cavity has been considered. It has been that the stiffening elements reduces the detuning in the static case, as expected. In the time transient simulations, the stiffening elements nearly make disappear the frequency deviations.

REFERENCES

- [1] H. Padamsee, RF Superconductivity: Science, Technology, and Applications, Wiley, New York, 2009.
- [2] S. Ellis, "SNS SRF time dependent cavity RF resonance shift due to Lorentz force induced mechanical excitation," Proceedings of the 2001 Particle Accelerator Conference, Chicago.
- [3] J.R. Delayen, G.K. Davis, "Microphonics and Lorentz Transfer Function Measurements on the SNS Cryomodules, proceedings of the 11th Workshop on RF Superconductivity, Lbeck/Travemnder, Germany (THP21).
- [4] H. Gassot, S. Blivet, T. Junquera, G. Olry, E. Zaplatine, "Mechanical Studies of the Multi-gap Spoke Cavity for European Project", Physica C 441 (2006) 190192.
- [5] K.W. Shepard, M.P. Kelly, J. Fuerst, M. Kedzie, Z.A. Conway, "Development of Spoke Cavities for RIA", Physica C 441, (2006), 205208.
- [6] T. Junquera, F.J. Bermejo, J.L. Munoz, A. Velez, P. Duschesne, G. Olry, "Design of a Superconducting 352MHz fully jacketed double-spoke resonator for the ESS-Bilbao proton linac" THP018, these proceedings.
- [7] COMSOL Multiphysics, <http://www.comsol.com>
- [8] S. Bousson, M.Fouaidy, H.Gassot, T.Junquera, J-C.Le Scornet, J.Lesrel, "SRF cavity stiffening by thermal spraying", Proceedings of EPAC 2000, Vienna, Austria.