

HORIZONTAL RF TEST OF A FULLY EQUIPPED 3.9 GHz CAVITY FOR THE EUROPEAN XFEL IN THE DESY AMTF

C. Maiano, C. Albrecht, R. Böspflug, J. Branlard, L. Butkowski, T. Delfs, J. Eschke, A. Goessel, F. Hoffmann, M. Hüning, K. Jensch, R. Jonas, R. Klos, D. Kostin, W. Maschmann, A. Matheisen, U. Mavric, W. -D. Möller, C. Müller, K. Müller, B. Petersen, J. Rothenburg, O. Sawlanski, M. Schmökel, A. Sulimov, E. Vogel, DESY, Hamburg, Germany, P. Pierini, INFN-LASA & DESY
A. Bosotti, M. Moretti, R. Paparella, D. Sertore, INFN-LASA, Segrate, Italy, E. Harms, R. Montiel, FNAL, USA, S. Pivovarov, BINP, Russia

Abstract

In order to validate the cavity package concept before the module assembly, one 3.9 GHz cavity, complete with magnetic shielding, power coupler and frequency tuner has been tested in a specially designed single cavity cryomodule in one of the caves of the DESY Accelerator Module Test Facility (AMTF). The cavity was tested in high power pulsed operation at 24 MV/m, above the vertical test qualifications and all subsystems under test (coupler, tuner, waveguide tuners, LLRF system) were qualified to design performances.

INTRODUCTION

The correct operation of a superconducting cavity in an accelerator requires a number of active and passive subcomponents for its proper operation. Among these a cold tuning system is needed to fine tune the cavity frequency, a power coupler needs to deliver the necessary power for the beam, a magnetic shield provides to the superconducting material shielding from the earth magnetic field and HOM antennas extract from the cold region the power possibly generated in the high order modes of the superconducting structure (while properly filtering the main accelerating mode). In addition, the cryomodule mechanical environment around the cavity needs to allow the relative differential contraction of different materials without introducing uncontrolled forces on the cavities that could perturb their frequencies.

Frequently, in order to validate the complete design of the cavity package in its operating environment a complete test of a cavity dressed with all its ancillary components is performed in a short horizontal cryostat, preferably providing a mechanical environment similar to that of its operation in the linac cryomodules.

THE XFEL 3.9 GHz SECTION

The European XFEL injector will host a cryomodule composed of 8 SCRF cavities at 3.9 GHz, for the linearization of the RF curvature experienced by the beam in the first 1.3 GHz accelerating module, before the bunch compressor [1]. The module design has been derived from the FLASH third harmonic section, developed by FNAL [2], with some major modification in the cavity package design, in particular the development of cavities with

alternate orientation of couplers with respect to beamline, to compensate coupler dipole kicks [3]. The cavities have been fabricated and vertically tested and the module has been prepared for tunnel installation; as described in several contributions to these Proceedings [4-6].

Figure 1 shows a 3D model of the 3.9 GHz dressed cavities (both orientations), equipped with cold tuners, cold main coupler part, RF antennas for the field probe and the HOM, and the magnetic shield (the top half of the parts connecting the cavities have been removed for better picture clarity).

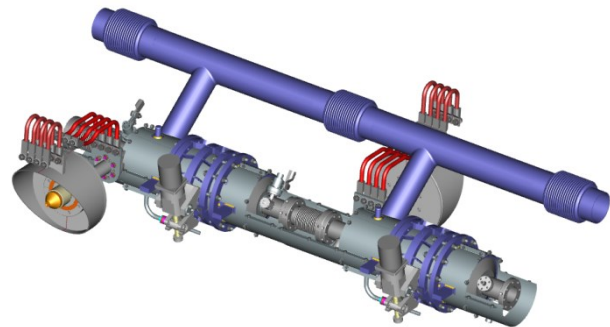

Figure 1: The two 3.9 GHz cavity packages, with opposing couplers.

For the preparation of the regular XFEL 1.3 GHz modules the cavities are individually tested in the AMTF [7], during the module qualification after assembly, before tunnel installation. In order not to interrupt the testing schedule of the 101 modules of the XFEL series, to limit the infrastructure work needed for adapting the AMTF for the testing of 3.9 GHz modules, and in view of the moderate performances needed by the 3.9 GHz cavities [1], the third harmonic system will be commissioned and characterized in the injector building after installation. Due to this fact, the qualification of the cavity package in a horizontal test represents an important verification to perform before the module assembly.

THE AMTF CRYOADAPTERS

Even if no single 1.3 GHz cavity horizontal tests were envisaged for the XFEL construction, two short (~2.2-meter) cryostats fitting the cryogenic connections of the AMTF test caves were delivered by BINP as part of the In

Kind Russian contribution to XFEL. These adapters will in the future allow testing of single 1.3 GHz cavities in a mechanical environment close to their operation. The cryoadapter setup in the AMTF is shown in Fig. 2.

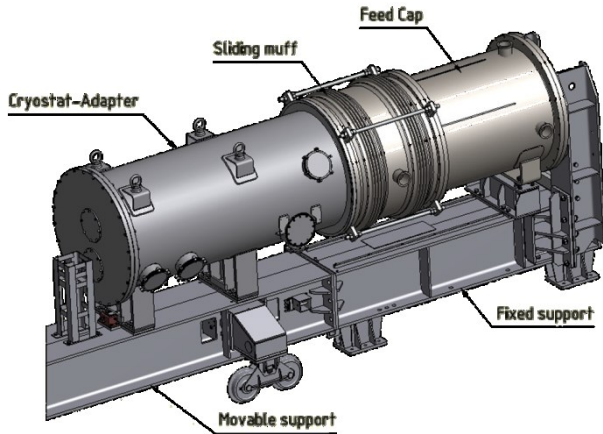

Figure 2: Cryostat-Adapter for the testing of single 1.3 GHz cavities.

In order to establish testing capabilities for the 3.9 GHz cavities one of the cryoadapter developed at BINP has been extensively modified, adding a second main coupler port on the opposing side of the existing one (to allow the installation of both 3.9 GHz cavity packages) and a new cavity suspension support, based on the geometry of the 3.9 GHz module developed at INFN.

Additionally, the XFEL accelerator test bench 1 XATB1 module test cave in the AMTF at DESY has been equipped with the RF infrastructure needed to test cavities at 3.9 GHz (klystron, modulator, LLRF crates and waveguide system). Figure 3 shows the RF infrastructure at XATB1.



Figure 3: LLRF racks (left) and the 3.9 GHz klystron and modulator racks in the XATB1 module test cave.

VERTICAL TEST QUALIFICATION

Cavity 3HZ010 has been selected and prepared for the horizontal test in the AMTF. The cavity was vertically tested at INFN-LASA, as all the other cavities produced for the 3.9 GHz string [5]. The vertical test (VT) has the aim of qualifying the cavity at the specified accelerating gradient and quality factor: $E_{acc}=15 \text{ MV/m} @ Q_0=10^9$.

The cavity was tested before the Helium tank integration [4], at 2 K, equipped with a fixed high Q antenna, field probe and HOM antennas, after the successful tuning of the HOM notch filters. The maximum E_{acc} in the test was determined by a quench occurring at 21 MV/m, with the cavity showing a Q_0 of $2 \cdot 10^9$ just before the quench. No field emission was detected in all range, leading to a full qualification. Figure 4 shows the characterization curve obtained in the VT.

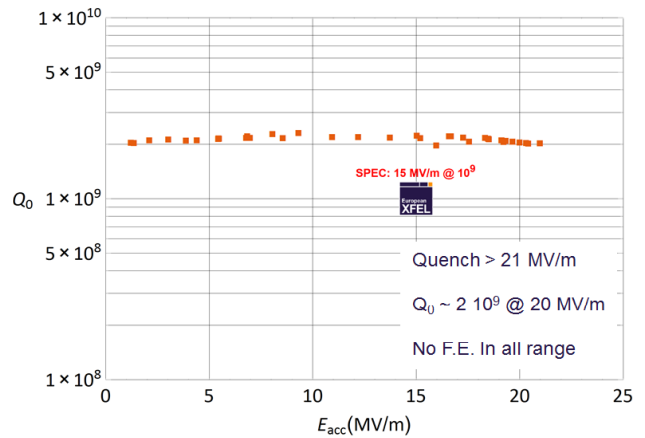

Figure 4: Q_0 vs E_{acc} during VT at LASA.

CAVITY PREPARATION FOR THE HORIZONTAL TEST

Cavity Dressing

After the VT at LASA the cavity has been integrated into its He tank at the manufacturer (Ettore Zanon), with a properly developed integration tooling that ensures that the cavity does not undergo any deformation during welding. The integration was performed under frequency control with a Vectorial Network Analyzer VNA.

In order to prepare the cavity for the horizontal test the complete installation of power coupler, magnetic shielding, and cold frequency tuner were performed at DESY. The tuner and magnetic shield installation is made under frequency control with a VNA to ensure that the cavity frequency is not altered by the mechanical operations within few tenth kHz.

RF Controls at Warm: Tuner and HOM Tuning

The INFN 3.9 GHz cavity tuner (of the blade type) is designed to induce a positive frequency shift at each motor spindle turn of about 180 kHz, for a maximal tuning range of about 1.5 MHz at 0.7 mm elongation [8]. Cavities are prepared at a frequency approximately 500 kHz below the expected cold frequency in order to avoid the tuner mechanical neutral point and a significant residual hysteresis around the working point.

After tuner installation, with the cavity supported on the sliding pads, a check of the tuner operation was performed a few times, on a short range (single motor spindle turn, to verify the correct assembly operation and the proper frequency response of the cavity.

The results of the tuner operation at warm after the cavity installation in the cryostat adapter are shown in Table 1.

Table 1: Tuner Operation at Warm

Motor action	Frequency shift	Hysteresis
One turn, then back	172 kHz	< 1 kHz
One turn, then back	177 kHz	< 1 kHz

Before installation in the cryostat adapter the transmissions across the cavity ports (Main Coupler MC-Pick Up PU, MC-HOM2, PU-HOM1) on the whole fundamental passband was acquired to check the proper HOM transfer functions and the correct position of the notch filters: after the assembly of the tuner and magnetic shield a slight detuning of the HOM filters is possible, due to their high sensitivity with respect to mechanical deformations. The main effect we experienced in several cavities is the detuning of HOM1, (the one which is directly opposite to the MC), due to the installation of the cold coupler antenna, changing slightly the field pattern in the end region of the cavity with respect to the high-Q antenna case. Figure 5 shows the evolution of the HOM relative transmissions starting from the cavity reception in DESY with the high Q fixed antenna to the preparation for the horizontal tests. The detuning of the HOM1 notch filter after the MC installation (Fig. 5b) lead to the retuning operation shown in Fig 5c, whereas the analysis of the relative transmissions measured before and after the cavity dressing show that these operations did not induce any detuning of the notch filter positions (Fig 5c and 5d).

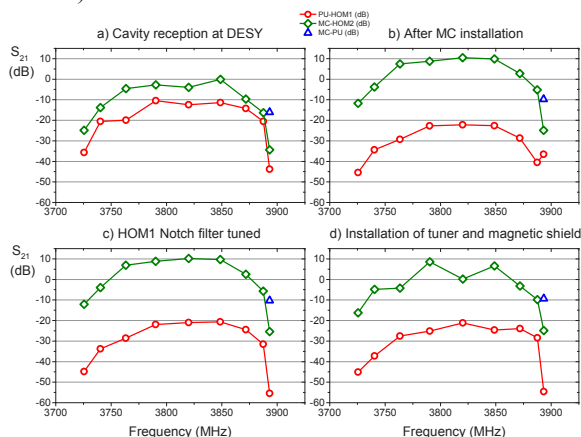

Figure 5: Evolution of the relative HOM transmission spectra of the fundamental passband: cavity reception (inset a), coupler installation (inset b, showing the detuning of the HOM1 rejection notch filter), HOM retuning (inset c), installation of all ancillaries (inset d).

The notch filter tuning for this cavity is generally considered satisfactory when the MC-HOM2 shows a relative transmission of at least 10 dB lower than the MC-PU on the accelerating pi mode and when the PU-HOM1 transmission on the pi mode is less than 20 dB than its

maximum on the fundamental bandwidth and 10 dB less than the neighbouring mode. These requirements are satisfied in the curves shown in Fig. 5 c and d. During VT no unexpected HOM power leaking on the fundamental mode was observed, confirming the preservation of the notch filter tuning during cooldown.

Assembly in the Cryostat Adapter

The cavity was then installed in the cryostat adapter, supported through a sliding mechanism using spring-loaded linear roller bearings similar to that used in the cryomodule for operation [9]. The warm coupler part has then been assembled using a local clean room. Figure 6 shows the cavity installed in the cryostat adapter (top) and the cryoadapter connected to the feed box (bottom).

The cryoadapter has a single thermal shield connected to the 40-70K circuit and supports the cavity through a tray sliding on a fixed rail suspended from the posts and thermalized by the 5-8 K circuit of the XATB. All RF and temperature sensor connections are routed to patch panels in the adapter to reduce the setup time of the tests.

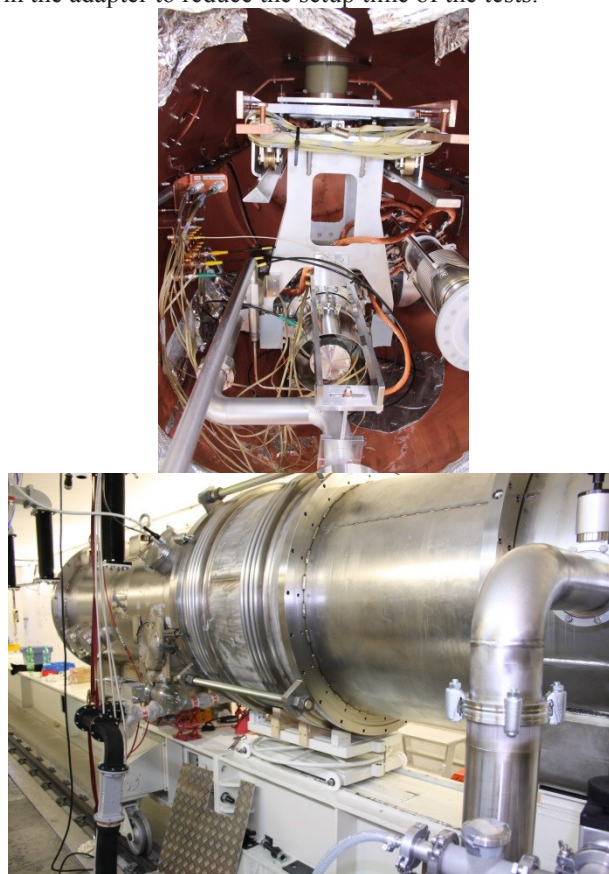

Figure 6: The 3HZ010 cavity installed in the cryoadapter before connection to the XATB1 cryogenic feedbox.

After the assembly of the cavity in the adapter the vacuum vessel was moved on the cryomodule support rail of XATB1 and rolled in the test cave to connect the cryogenic circuits, the cavity beam vacuum and the 3.9 GHz waveguides from the klystron to the warm coupler waveguide box. The insulation vacuum was then closed using the feed cap sliding muff.

HORIZONTAL TEST RESULTS

Cooldown

Cooldown started on March 19th 2015, with the standard fast cooling procedures used for the module tests in AMTF [7], where process pipes are cooled down to the nominal temperatures in approximately 14 hours. Fig. 7 shows the inlet and outlet temperatures of the thermal shields and the temperature of the cold box in the feed cap which feeds the 2 phase 2K cavity line. Pumpdown to 2 K started on March 23rd 2015, followed by cold tuning and low power measurements for calibration. High power operation and LLRF tests started on March 25th 2015. Warmup started on March 27th 2015.

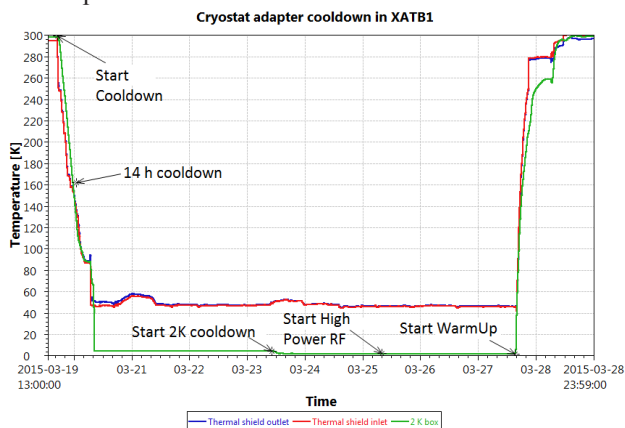

Figure 7: Cooldown/warmup cycle of the cryoadapter for the 3.9 GHz horizontal tests.

Pretuning at Cold, Tuner Range Test at Cold

The warm to cold frequency shift experienced during all vertical tests of the cavities before integration was 6.1 ± 0.1 MHz [4]. The frequency of the 3HZ010 after cooldown increased by 6.17 MHz, in full agreement of the VT experience and indicating that tank integration and the cavity supporting scheme in the module lead to no undesirable or uncontrolled stresses on the RF structure due to differential material shrinkage.

The cavity tuning and preparation scheme foresees a frequency offset with respect to the operation frequency of approximately -500 kHz, in order to always operate the blade tuner far from its mechanical neutral (rest) point.

After reaching a stable 2 K cavity condition, the cavity was tuned to 3.9 GHz under the control of a VNA, to monitor the cold tuning action and to verify the tuner performances. Each motor screw turn requires 70400 steps of the stepper motor and the cavity was brought to the VNA frequency of 3.9 GHz with 246200 steps, corresponding to roughly 3.5 screw turns and providing the necessary 551 kHz of tuning action to reach the operation goal.

The maximal tuning stroke for the tuner design, well before the onset of cavity plasticity, is obtained by 15 screw turns, corresponding to a frequency tuning action in excess of 1.5 MHz [8].

Table 2 summarizes the cold-warm cavity frequencies and the tuner characterization results.

Table 2: 3HZ010 Frequency History and Tuner Parameters

Cavity Status	Frequency
Warm Frequency before cooldown	3893.279 MHz
Cold Frequency after cooldown	3899.449 MHz (+6.17 MHz)
Tuner parameter	Value
Motor turns to 3.9 GHz	~ 3.5
Frequency offset/turn	171 kHz (1 st turn) 166 kHz (2 nd turn) 160 kHz (3 rd turn)
Frequency offset/motor step	2.2-2.4 Hz

Figure 8 shows the cavity frequency and tuner frequency offset/turn during the tuning process.

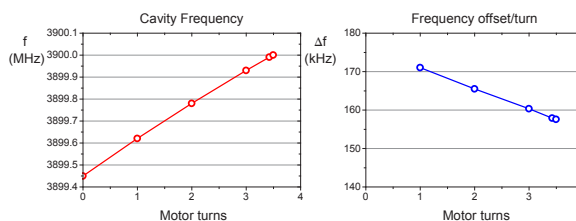

Figure 8: Cavity frequency (left) and tuner frequency offset per motor turn (right) during the tuning process.

After bringing back the tuner in its original position the cavity restored to its original frequency, no hysteresis effects below the 10-20 kHz range could be measured given the relatively large noise environment in the low transmission measurement.

Low Power Measurements and Calibration

The accelerating gradient is one of the cavity key parameters, thus the cavity Loaded Quality factor, Q_L , and the cavity probe calibration constant k_t were determined at moderate forward power from the main coupler (~ 1 kW), by the measurement of the decay constant of the transmitted power and the power balance. Once the calibration is performed the cavity accelerating field can be determined from the measured transmitted probe power P_t with the simple relation $E_{acc}[V/m] = k_t \cdot \sqrt{P_t}$.

The 3.9 GHz coupler is of the fixed coupling type [10], and the nominal XFEL beam parameters require a coupling with $Q_{ext} = 3.2 \cdot 10^6$, i.e. nearly twice the ACC39 value for FLASH [2], thus the coupler antenna were trimmed at a different length with respect to the original design, extrapolating the FNAL trimming experience. Three stub tuners on the waveguides allow the coupling factor fine tuning, at least a factor of 2 in both directions. The measurement of the 3HZ010 cavity yielded a value of $Q_{ext} = 4.25 \cdot 10^6$, well within the range. Figure 9 shows the calibration pulse.

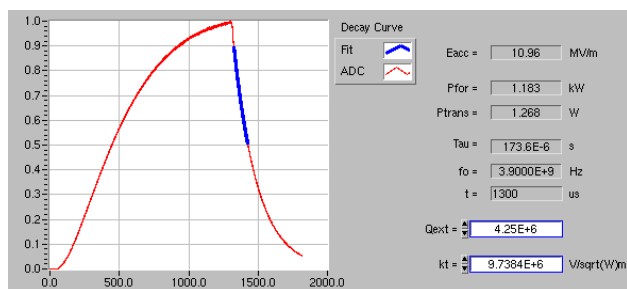

Figure 9: Low power calibration pulse (shown in arbitrary units).

Table 3 summarizes all the calibrations performed during the 3HZ010, for the Q_{ext} of all antennas and for the probe calibration constant, and compares it to the values determined during the VT. A good agreement is found.

Table 3: Comparison of VT and HT Calibrations

Item	VT	HT
Q_{PU}	$1,3 \cdot 10^{10}$	$1,5 \cdot 10^{10}$
Q_{HOM1}	$8,8 \cdot 10^{13}$	$2,2 \cdot 10^{13}$
Q_{HOM2}	$2,5 \cdot 10^{12}$	$1,5 \cdot 10^{13}$
k_t	$9,16 \cdot 10^6$	$9,74 \cdot 10^6$

High Power Measurements

The cavity was then operated in open loop with 10 Hz pulses with a filling time of $500 \mu s$ and a flat-top time of $600 \mu s$, starting with the fine frequency tuning and then rising the input power to bring the cavity to its quench limit, which occurred right before 24 MV/m, above the quench level experienced in the quasi-CW vertical tests (21 MV/m).

Stable operation was kept at 20 MV/m for nearly 48 hours without any appreciable sign of field emission or cavity heating shown at the CERNOX sensors positioned on the cavity vessel and in three positions on each HOM port. A typical pulse measurement is shown in Fig. 10.

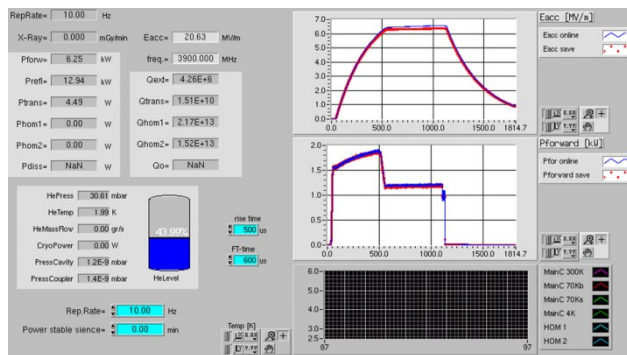

Figure 10: Typical pulse measured during the long stable operation at 20 MV/m. E_{acc} and forward power are shown in arbitrary units.

Dynamic Loss Estimates

The stable 2 K operation of the cryostat adapter in the AMTF required a 25 W setpoint for the cold box heater. The average cavity dissipated power at 20 MV/m is only 0.35 W at 1% duty cycle, therefore no precise measure of dynamic heat losses is possible. Tests were performed in two setups: the first keeping the Helium level control and evaluating the heater difference from RF-on and RF-off states; the second using precise mass flow controllers and switching the heaters and Joule-Thompson valve off (i.e. decreasing the He level). These two methods indicated values of 0.2 W and 0.6 W, respectively, compatible with the estimation and the large uncertainty of the setup.

3 Stub Tuner Operation

The 3-stub tuner at the waveguide was operated to change the system Q_L values, and more than a factor 2 variation was observed (though the central step motor connection was damaged during installation and the system could only tune to higher Q_L values).

CONCLUSIONS

The cavity package for the 3.9 GHz XFEL system, including tuner, couplers and ancillaries, was qualified in a horizontal test in the AMTF facility at DESY.

REFERENCES

- [1] P. Pierini et al., "Preparation of the 3.9 GHz System for the European XFEL Injector Commissioning", these Proceedings, TUPB018.
- [2] E. Vogel et al., "Test and Commissioning of the Third Harmonic RF System for FLASH", Proceedings of IPAC'10, Kyoto, Japan, p.4281.
- [3] P. Pierini et al., "Third Harmonic Superconducting Cavity Prototypes for the XFEL", Proceedings of LINAC'08, Victoria, CA, p. 821.
- [4] P. Pierini et al., "Fabrication of the 3.9 GHz Structures of the European XFEL", these Proceedings, THPB035.
- [5] D. Sertore et al., "Vertical Tests of XFEL 3rd Harmonic Cavities", these Proceedings, MOPB077.
- [6] M. Schmökel et al., "Assembly of a 3.9 GHz String for the EXFEL at DESY", these Proceedings, TUPB105.
- [7] M. Wiencek et al., "Update and Status of Test Results of the XFEL Series Accelerator Modules", these Proceedings, MOPB080.
- [8] R. Paparella et al., "Coaxial Blade Tuner for European XFEL 3.9 GHz Cavities", Proceedings of SRF'13, Paris, France, p. 1101.
- [9] D. Barni et al., "Friction Measurements for SC Cavity Sliding Fixtures in Long Cryostats", Proceedings of CEC'99, CA, ISBN 0-306-46443-8.
- [10] J. Li et al., "RF Design and Processing of a Power Coupler for Third Harmonic Superconducting Cavities", Proceedings of PAC07, NM, USA, p. 2265.