

DEVELOPMENTS ON A COLD BEAD-PULL TEST STAND FOR SRF CAVITIES

A.Vélez, A. Frahm, J. Knobloch, A. Neumann, Helmholtz-Zentrum Berlin, 12489 Berlin, Germany

Abstract

Final tuning and field profile characterization of SRF cavities always takes place at room temperature. However, important questions remain as to what happens when the cavity is cooled to LHe temperature, in particular with multi-cell systems. To enable the characterization of cavities in the cold, we have designed and commissioned a "cold bead-pull" test stand at HZB. The present test-stand is designed to be integrated in HoBiCaT (Horizontal bi-cavity testing facility) [1] with the ability to provide electric field profile measurements under realistic superconducting conditions ($T=1.8\text{K}$). In this paper mechanical and operational details of the apparatus will be described as well as future plans for the development and usage of this facility.

INTRODUCTION

Cavity tuning is the final process step after the fabrication of a new SRF cavity. This process will lead to the achievement of the field flatness specification and therefore to the final acceptance of the cavity. Valuable information such as the field profile and R/Q can be accurately determined and compared to electromagnetic simulations in order to determine the fabrication accuracy and cavity performance. In order to perform this test a so called bead-pull test stand is needed. The theory of the system is based on the Slater's perturbation theory and takes advantage of the frequency deviation induced by the pass of a perturbing object through a cavity in order to determine the induced field profile. To this end, many different mechanical systems have been developed and serve as a cavity analysis and commissioning tool for many very different cavities in several labs [2,3]. Nevertheless, this test is always performed at room temperature even for Niobium based cavities, which superconducting physical characteristics substantially differ from the warm state to [4]. As it is known once the cavity is at 1.8K the natural frequency shifting due to thermal shrinkage can be easily measured. Nevertheless, after the last tuning is performed at room temperature and the cavity is taken to a S.C. state there is no measured evidence of the conservation of its field profile. To investigate this problem HZB presents a first prototype of a test-stand able to perform bead-pull measurements under superconducting conditions. The system has been successfully tested in HoBiCaT [1] for a 1.3GHz 9-cell Tesla cavity and the results obtained are presented on this paper.

BEAD-PULL TEST STAND

HZB's cold bead-pull test-stand is designed to be allocated in the horizontal tests of superconducting cavities (HoBiCaT [1]). Due to the reduced available space inside the cryo-module the design is required to be as compact as possible. Therefore, an aluminium frame sustaining the cavity structure and the bead-pull equipment at the same time has been fabricated. Also due to the limited space, the system is design to slide over a 2K cooled table in order to allow cavity preparation and bead mounting outside of the module. In addition the typical weigh-hanging structure [3] has been replaced by a winding/releasing threaded wheel system directly connected to the motor axis (Fig. 1). Therefore the system is bi-directional in a closed loop. The motor used consists on a VSS52 with transmission gear typically used for tuner actuation and suitable for low temperature operation. In order to supply the proper tension needed on the wire, a tension pulley has been implemented (see Fig. 2a). This pulley is attached to the aluminium frame by means of a metal spring providing the tension needed.

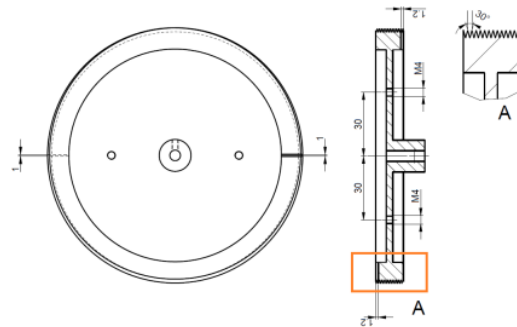

Figure 1: Winding threaded wheel.

Due to the tension needed and the low temperature operation (1.8K) there is a material selection limitation on the wire to be used. Titanium based wires would represent a perfect choice in terms of strength at low temperatures. Nevertheless its metallic characteristics will change boundary conditions and therefore disturb field characteristics inside the cavity. Thus a Kevlar based string has been chosen. A material validation successful initial cold-stress test for the wire was performed by immersing a sample into liquid Nitrogen and applying tension to it.

A layout of the aluminium test-stand frame holding the cavity is depicted in Fig. 2. As it can be seen three extra pulleys have been added in order to handle the pass of a plastic tube through the cavity. This tube will serve as a

support for the wire to go through the cavity without damaging the inner surface (Fig. 2b).

Before running the system for the first time, it is necessary to accurately allocate the bead's entrance and exit points to the cavity in order to set the proper length for the motor run and to avoid the bead to reach the end pulleys and therefore a system crash. To do so, two magnetic sensors have been properly allocated on the upper part of the structure. A metallic flag attached to the wire is used as a trigger for these sensors (Fig. 2a). Figure 3 shows a picture of the 9 cell Tesla cavity installed in the cold bead pull-system inside HoBiCaT.

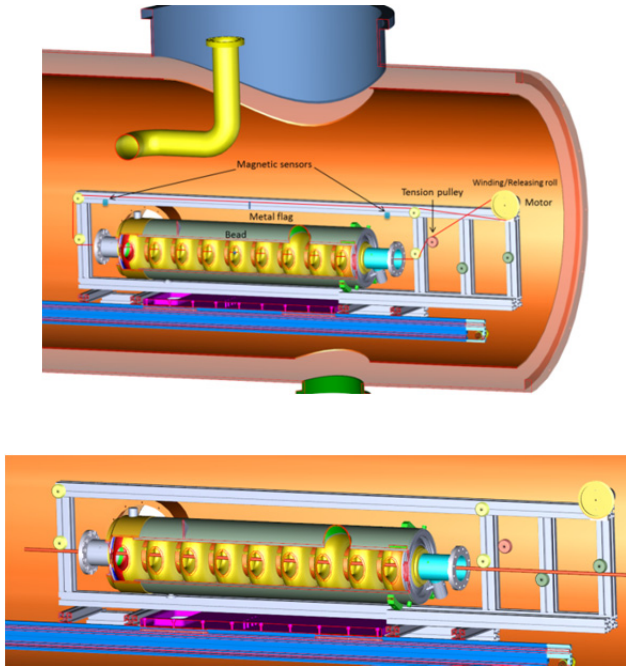

Figure 2: Test cavity mounted with the wire system inside the HobiCat cryo-module (a). System with the thread tube (b).

First Cold-Test

For a first cold-test with the 1.3GHz 9-cell Tesla cavity, a metallic sphere of 3.5 mm diameter was chosen. This size and material were selected on the basis of previous measurements performed with the same cavity at room temperature with a 4 mm diameter bead. At room temperature phase deviations in the order of 1° were observed when measuring the fundamental TM_{010} π -mode. A small size reduction of the bead (0.5mm) was assumed to be convenient in order to account for possible longer phase deviations in the SC state due to higher quality factors. In order to excite the cavity two antennas were placed at the FPC and field probe port positions. Due to their location far from the cavity on the beam pipe section both antennas were set to couplings with $\beta < 0.1$. All measurements were performed with a continuous 0dBm power level supplied by means of a network analyser.

The first cold-test (1.8K) was successfully run with no mechanical failures. In this first run, the whole fundamental pass band (TM_{010}) was measured (Fig.4). As it can be inferred, a large phase deviation is observed. In particular a 130° phase difference is measured for the fundamental TM_{010} π -mode. As explained before, some increase in the phase deviation was expected since Q_1 is increased from values in the order of $1e4$ (warm) to $1e6$ (1.8K). This effect can be derived from equations 1 and 2 where an increase in Q_1 consequently rises the slope of the E_z vs Phase curve (equation 3). As consequence this type of experiment becomes very sensitive to Q fluctuations.

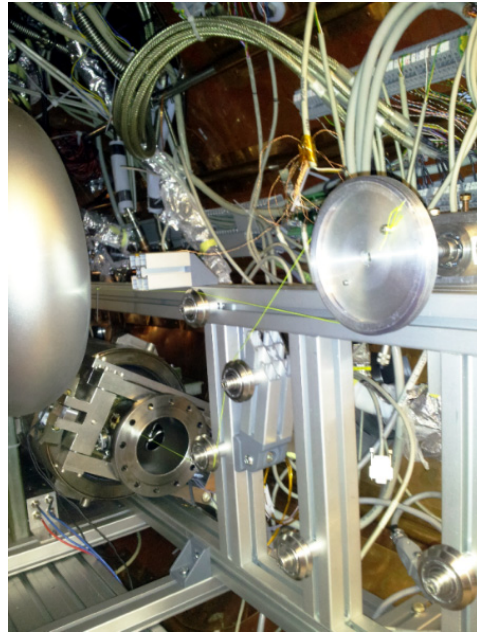

Figure 3: Picture of the test-stand after mounted into HoBiCaT.

$$\Delta \text{ang} (S21) \approx -2 \cdot Ql \frac{\Delta f}{f} \quad (1)$$

$$\frac{\Delta f}{f} \frac{F_{\text{bead}}}{\omega} = \frac{|E_z|^2}{\omega U} \quad (2)$$

$$\Delta \text{ang} (S21) = -2Ql \frac{|E_z|^2}{U \cdot F_{\text{bead}}} \quad (3)$$

In fact, for some of the modes like π , $8/9 \pi$ and $7/9 \pi$, the interaction between the spherical bead and the cavity is too strong clearly showing some level of saturation on the phase curve. Nevertheless, modes with phase difference below the 45° threshold ($5/9 \pi$, $4/9 \pi$, $3/9 \pi$ and $2/9 \pi$) show a non-saturated performance and can be accurately characterised. Unfortunately, low order modes like the $2/9 \pi$ and $1/9 \pi$ are weakly coupled and therefore the measured field response shown a very noisy figure.

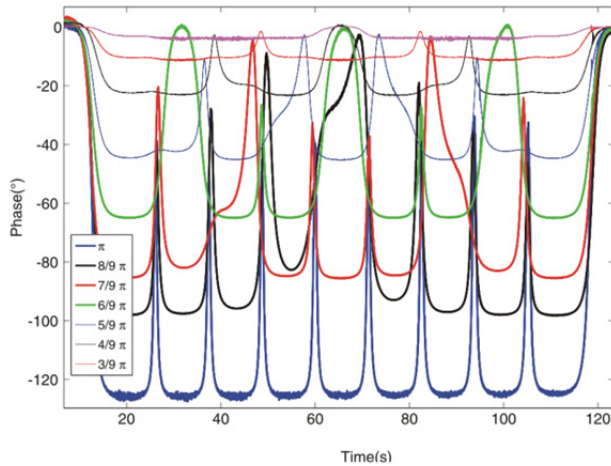

Figure 4: Measurement results on the fundamental TM_{010} pass-band with spherical metallic bead (3.5mm).

Second Cold-Test

A second cold-test was performed in order to try to minimize the excitation produced by the bead-cavity interaction and therefore being able to extract field profiles for previously saturated modes. To this end a cylindrical metallic bead was used (2mmx4mm) and a second run performed and the whole fundamental TM_{010} band measured. As it is depicted in Fig. 5 the phase deviation was reduced in 40° for the TM_{010} π -mode when compared to the sphere case and consequently saturation level reduced. Nevertheless and different from the sphere case, the cylinder-cavity interaction for the TM_{010} π -mode results in the smaller phase deviation case when compared to the rest of the lower band modes (see Fig. 5).

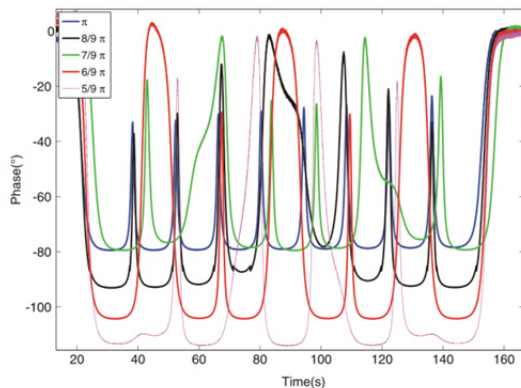

Figure 5: Measurement results on the fundamental TM_{010} pass-band with a cylindrical metallic bead (2mm x 4mm).

In order to be able compare the results obtained with bead-pull in a “warm state” HoBiCat was raised to room temperature. Then, a new warm run was performed with the use of the same cylindrical bead and results compared to the cold cases.

As one could expect, due to the superconducting reduced losses HOM excitation results more effective than under warm conditions. Therefore the presented cold bead-pull system represents a very useful tool when trying to characterise HOMs which would be otherwise unable to be excited or too noisy to be measured. Figure 6 shows a comparison between the HOM spectrum of the cavity up to a frequency of 3GHz.

To demonstrate this effect and in order to compare the saturation effects on the cold measure of HOMs the TM_{011} and TM_{020} were measured and compared to the warm case. Figure 7 depicts the comparison between the warm and cold states for the TM_{020} $6/9$.

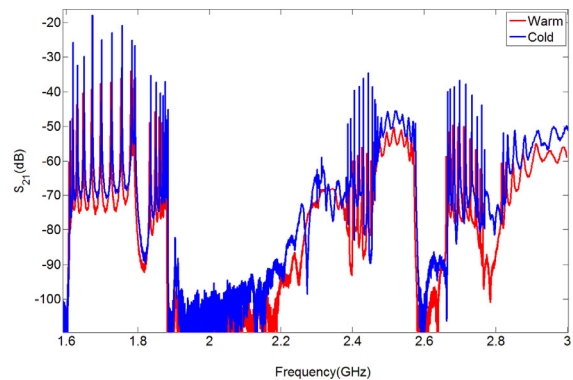

Figure 6: Measurement HOM spectrum for both warm (red) and cold (blue) states.

These modes were selected because of their good performance also in the warm state and therefore possible comparison. In these cases no saturation effects are observed even for a big phase deviation (70° for TM_{020} $6/9$ π -mode). Figure 8 shows the comparison between the three different TM_{010} π -mode measurements (cold vs warm). As it can be seen the warm maximum phase deviation is in the order of 15° while no saturation effect is observed. As a consequence some deviation in the field flatness can be identified. As it was previously pointed out both cold measurements for the TM_{010} π -mode show some degree of saturation and almost flat field flatness is observed. This is of course an unrealistic representation of the phase profile which can be due to the combinations of different factors such as the higher field values present in the superconducting state, high Q_1 and differences in the mode coupling. This last factor combined with the mode sensitivity to the bead shape and material represents the most limiting aspect as depicted in Figs. 4 and 5.

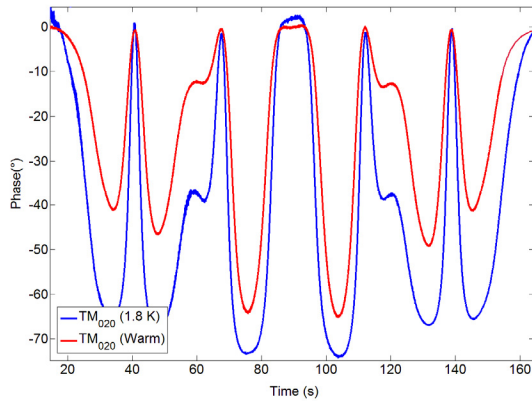

Figure 7: Comparison between warm and cold measurements (cylindrical) for the fundamental TM_{020} $6/9 \pi$ -mode.

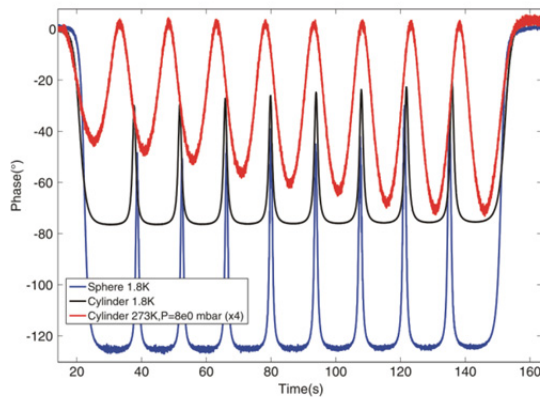

Figure 8: Comparison between warm and cold measurements (spherical/cylindrical) for the fundamental TM_{010} π -mode.

Improvements and Future Work

On the basis of the obtained results it is clear that an SRF cavity under superconducting conditions shows a very high sensitivity to the bead perturbation. This represents a positive point when characterising HOMs or particular modes showing a limited sensitivity such as the $4/9 \pi$, $3/9 \pi$ and $2/9 \pi$ when using a metallic spherical bead. Nevertheless this effect is a major drawback when measuring the fundamental π mode since a realistic field profile cannot be obtained. Therefore a new set of measurements is foreseen with the use of a spherical dielectric bead with a diameter smaller 3.5mm in order to neglect the saturation effect. In addition, a proper cold bead characterization is planned in order to be able to extract the precise form factors under cold conditions. To this end, a pill-box cavity will be measured in the cold bead-pull test stand.

CONCLUSION

This paper presents the successful realization by HZB of a first cold bead-pull test stand. The system has been tested at 1.8K by measuring the field profile for the fundamental TM_{010} band and several high order modes of a 9-cells Tesla cavity. Results show very high sensitivity to different bead-shapes and sizes and especially when compared to standard warm bead-pull measurements. In conclusion the presented cold bead-pull system has proved to be a very interesting tool in order to test and commission future SRF cavities. Nevertheless still more work needs to be devoted in order to fully control the bead specifications needed for the different measurements.

REFERENCES

- [1] O. Kugeler, A. Neumann, W. Anders, and J. Knobloch, Review of Scientific Instruments 81, 074701 (2010).
- [2] R. Ainsworth et al. "Bead-Pull test bench for stuying accelerating structures at RHUL", Proceedings IPAC2011, MOPC049.
- [3] R. Ainsworth et al. "Bead-pull measurement method and tuning of a CLIC CRAB cavity", Proceedings of LINAC2014, MOPP035.
- [4] Haipeng Wang et al. "Simulations and measurements of a heavily HOM-damped multi-cell SRF cavity", Proceedings of PAC2007, WEPMS070.