

COUPLERS, TUTORIAL AND UPDATE

E. Haebel
CERN, Geneva, Switzerland

Abstract

First a tutorial on couplers is given. Describing the coupling effect in the form of an equivalent generator picture, a resonator approach to coupler design, is developed and illustrated taking the HOM couplers of DESY/HERA and CERN/LEP as examples. In a second part more recent technical developments are evoked and commented.

1. INTRODUCTION

The conceptual work on accelerators for high-energy physics progresses in two directions: highest beam energies with moderate intensities and highest intensities with moderate energies.

Both branches of development consider superconducting (s.c.) cavities because, in maintaining high efficiency, they allow to combine high gradients with large iris apertures and hence low short range wake field levels.

But a prerequisite of their use is that long range wakes are also controlled. Superconducting wall losses are too small to help and the use of special higher-order-mode (HOM) couplers imposes itself. In consequence, their development started together with that of s.c. cavities [1]. A review of the state-of-the-art has been given at the last workshop [2].

Now, two years later, a new review does not appear necessary but only an update and time will be left for another task. In view of the new accelerator projects, R&D on couplers and HOM damping will get a new *impetus*. New people join the field and, following a suggestion of the organizing committee, I will start with a coupler tutorial followed by a short account of recent developments.

2. TUTORIAL ON COUPLERS

2.1 Higher-order-mode couplers and the notion of matching

Sometimes, in a discussion of a HOM coupler design the question is asked, how HOM coupler and cavity are *matched*. The answer is: HOM couplers are not matched, only input couplers are.

HOM couplers shall provide *damping*, the more the better. In operation as part of an accelerator and for a certain energy U within a parasitic cavity mode, they shall extract power from it and the higher P_{ex} or equivalently the lower $Q_{ex} = \omega U / P_{ex}$ the better.

Let us represent a cavity resonance by a LC-resonator.

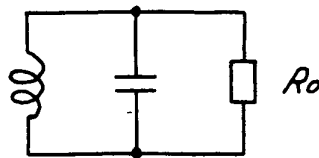

R_0 represents the inner (wall) losses of the cavity. The HOM coupler then connects an external resistor R_{ex} in parallel

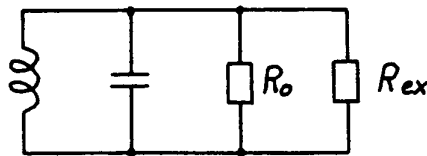

and the task is not to match, i.e. to make $R_{ex} = R_0$, but to make R_{ex} as small as possible, at least 100 times smaller than R_0 so that HOM dissipation into the cavity walls becomes negligible.

2.2 Input couplers and matching

Input couplers in contrast are most often designed to provide a match. They are the last link in a chain of elements used to transfer radio-frequency (RF) power from a generator to a cavity and evidently we want a minimum of transmission losses. This implies that the standing wave ratio on all transmission lines must be kept near to one.

The main task of the input coupler is then to act as a *transformer* between the cavity's accelerating voltage V_{acc} and the transmission line voltage V at the coupler input. Let us illustrate again the situation by an equivalent circuit.

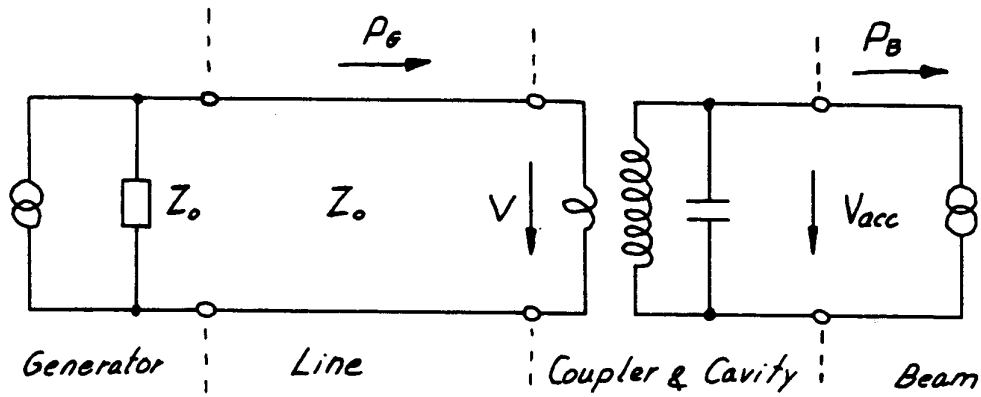

Fig. 1

We have at the left the Helmholtz model of a RF power generator with source resistance Z_0 . This might be a Tetrode or Klystron *equipped with a circulator*. It follows to the right a transmission line with wave impedance Z_0 , coupler, cavity and the beam, described by a current source.

Let the beam extract the power P_{B0} from the cavity, let the line be matched on both sides and let the coupler and the cavity be free of losses^(*).

Matching then means that V_i , the incident voltage, is equal to the input voltage V of the coupler, i.e. the coupler absorbs the incident power P_G without reflection and^(**)

$$P_G = \frac{1}{2} \frac{V_i^2}{Z_0} = P_{B0}. \quad (1)$$

Replacing $V_i = V$ by V_{acc}/n , where n is the coupler's *voltage transformation ratio*

$$\Rightarrow \frac{1}{2} \frac{V_{acc}^2}{n^2 Z_0} = P_{B0}, \quad (2)$$

$$\Rightarrow n^2 = \frac{1}{2} \frac{V_{acc}^2}{Z_0 P_{B0}}, \quad (3)$$

Instead of measuring the coupling by n , we use more conveniently the damping of the cavity by the generator's transformed source resistance $n^2 Z_0$. Exposed to V_{acc} this resistor would consume a power

$$P = \frac{1}{2} \frac{V_{acc}^2}{n^2 Z_0}, \quad (4)$$

which, as shown just before, is equal to P_{B0} . Using the general definition of $Q = \omega U/P$

(*) We neglect the small wall losses of the s.c. cavity.

(**) P_{B0} is the beam power to which we want to match.

$$\Rightarrow Q_{\text{ex}} = \frac{\omega U}{P_{\text{B0}}} . \quad (5)$$

Using then the definition of the coupling impedance $(R/Q) = V_{\text{acc}}^2/(2\omega U)$

$$\Rightarrow Q_{\text{ex}} = \frac{1}{2} \frac{V_{\text{acc}}^2}{(R/Q) P_{\text{B0}}} . \quad (6)$$

With eq. (2) $n^2 Z_0$ can now be expressed by

$$n^2 Z_0 = Q_{\text{ex}}(R/Q) . \quad (7)$$

As an example, a LEP 4-cell cavity has $(R/Q) = 230 \Omega$ and operates at $V_{\text{acc}} = 8.6 \text{ MV}$. One Klystron of 1 MW feeds 16 cavities. 60 KW are available per cavity and can be transferred to the beam if we match at that power level, i.e. use in eq. (6) $P_{\text{B0}} = 6 \times 10^4 \text{ W}$.

$$\Rightarrow \boxed{Q_{\text{ex}} = 2.66 \cdot 10^6} .$$

This value is set and controlled in measuring the bandwidth of the cavity with the coupler mounted and fed from a source with source resistance Z_0 (normally 50Ω). For the LEP example one has to find

$$\Delta f = 3.5 \cdot 10^8 \text{ Hz} / 2.66 \cdot 10^6 = 132 \text{ Hz} .$$

2.3 Power demand of an overcoupled and detuned cavity

After having set the coupling, cavity operation with the same voltage V_{acc} but smaller beam powers P_{B} results in a mismatch and more generator power than beam power will be needed. One finds (derivation in the appendix 1)

$$\frac{P_{\text{G}}}{P_{\text{B0}}} = \frac{1}{4} \left(1 + \frac{P_{\text{B}}}{P_{\text{B0}}} \right)^2 . \quad (8)$$

This relation is plotted in fig. 2. The diagonal gives the power demand for ideal matching (which requires a readjustment of coupling each time the beam power is changed). Fortunately, operation with fixed coupling does not dramatically increase the power demand over the ideal one. For half the matched power, $P_{\text{B}} = P_{\text{B0}}/2$, the additional demand is only 12.5% of P_{B} . We also see that with no beam one quarter of P_{B0} is needed to produce V_{acc} .

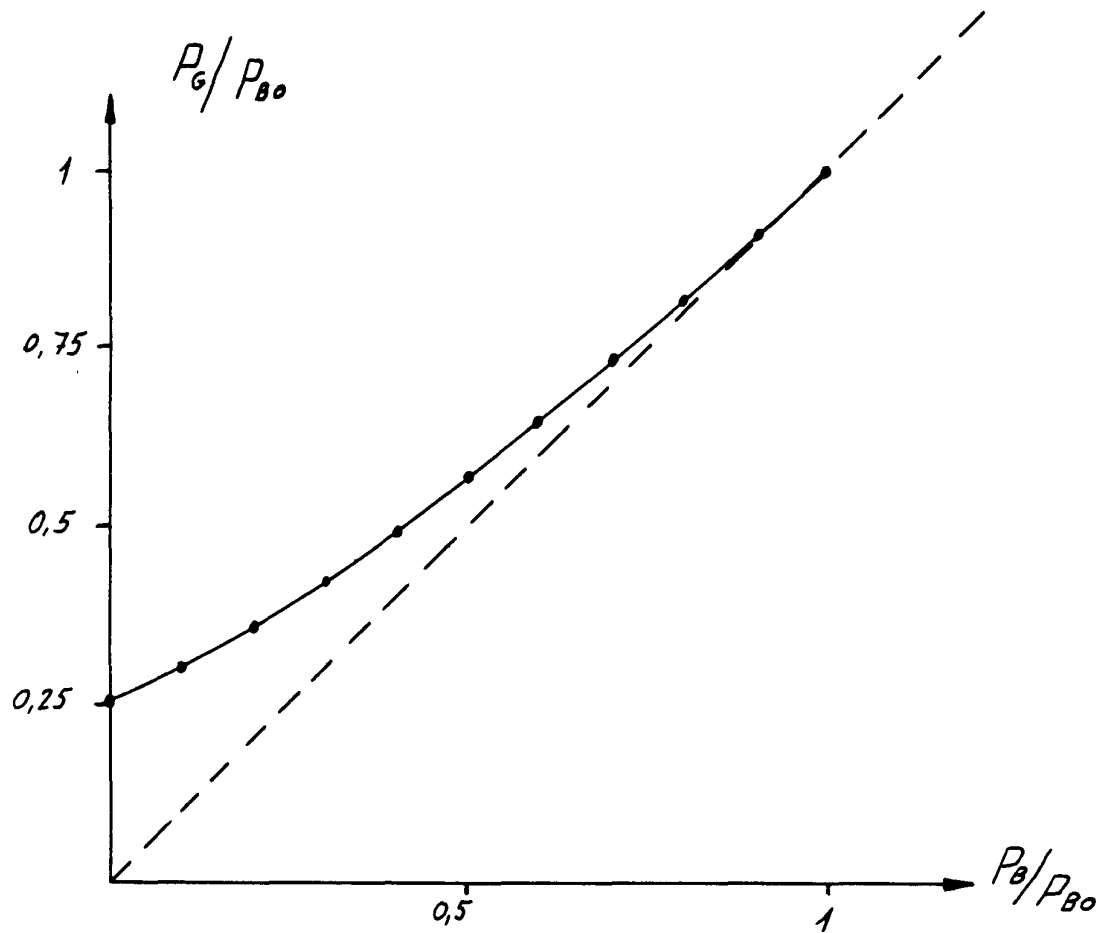

Fig. 2 Generator power for $P_B < P_{B0}$

Another cause of enhanced generator power need is a perturbation δf of the cavity frequency as caused for instance by He pressure variations or other external vibrational sources. But there is also an unavoidable inner source, the radiation pressure of the cavity field.

Such perturbations may be too fast to be compensated by the tuner. To keep the cavity voltage constant, then amplitude and phase of the generator voltage must be varied. As derived in the appendix this "active" compensation approach requires a surplus δP of generator power.

$$\delta P = P_{B0} \left(\frac{\delta f}{\Delta f} \right)^2, \quad (9)$$

$\Delta f = f/Q_{ex}$ is the 3 dB bandwidth. In LEP additional 15 KW would be needed to compensate the perturbing effect of a 66 Hz cavity frequency deviation.

2.4 Matching and the high current Robinson limit

In circular accelerators the RF cavities are not only used to furnish power to the beam but also to provide longitudinal focusing of the bunches. For that purpose the power transfer to the bunches must depend linearly on their arrival time in the cavity. For beam energies above the transition energy of the accelerator the power transferred must decrease if the bunches are late and *increase* if the bunches are early (with respect to the arrival time of synchronous bunches).

But for a s.c. RF system operated at a constant generator power P_G and matched to a beam of synchronous bunches (so that $P_B = P_G$) *any* change of the arrival time and thus of the beam current's phase will lead to power reflection and thus only to a *decrease* of transferred power. The matching beam current is in fact at the limit [3] of the stable region defined by the second criterion of Robinson [4].

$$\sin 2\alpha < 2(I_0/I_B) \cos \varphi_s . \quad (10)$$

Here I_B is the beam current (its RF component) and φ_s its synchronous phase angle. I_0 is the current through the transformed source impedance ($I_0 = V_{acc}/(n^2 Z_0)$) and α the phase angle of the impedance $Z = n^2 Z_0 / (1 + j2 Q_{ex} df/f)$ (the so-called tuning angle).

An obvious way to stay within the stable region is to overcouple, i.e. to match for a bigger beam current than the nominal one and to accept some power reflection. An even simpler way is to produce reflection by a detuning of the cavity [5]. But it will be more efficient to use active methods like RF feedback or feedforward [6] which change P_G to stabilize amplitude and phase of the accelerating voltage.

Let us now return to the discussion of HOM couplers which must be designed to interact most strongly with all dangerous HOM but not at all with the fundamental mode. As we will see, we then encounter a problem of reactance compensation, i.e. a limiting case of *conjugate* matching to a source of purely reactive internal impedance.

3. THE BASICS OF DAMPER DESIGN

3.1 The equivalent generator approach

Think about a cavity equipped with a port which houses a probe or a loop.

Imagine a mode of the cavity excited to a stored energy U . We now can regard the port as the output port of a RF generator and hence may try to describe it by an internal impedance and an active source. Here we have the choice between a voltage source in series or a current source in parallel with the impedance.

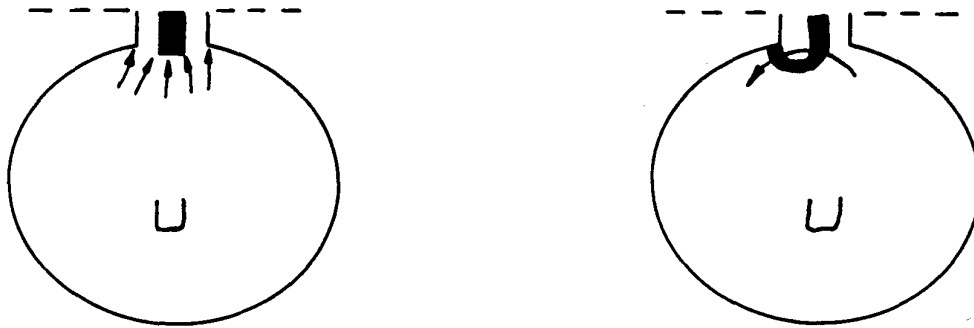

We determine these two equivalent components by a measurement of open-circuit voltage and short-circuit current at the cavity's output port (for a given U) and find for the loop an internal *reactance* (without any resistive component). It is the reactance of the loop's self inductance and any parasitic inductance in series with the loop.



V_0 is the induced voltage

$$V_0 = \omega \phi = \omega \mu_0 \iint H \, ds \quad (11)$$

H is the magnetic cavity field and we integrate over the loop area. For the probe we find a circuit *dual* to that of the loop.

C_s is the probe's self capacitance plus any parasitic (fringe) capacitance in parallel and I_0 the displacement current picked up by the probe with a short circuit across the port

$$I_0 = \omega \times \epsilon_0 \iint E \, ds \quad (12)$$

E is the electric cavity field and we integrate over the probe area.

3.2 A resistive load as termination

If we now connect a load resistor we find the dissipated power to depend on its value R . We get a maximum of

$$P = \frac{1}{4} V_0^2 / (\omega L_s) \quad \text{at} \quad R_{\text{opt}} = \omega L_s \quad \text{for the loop}$$

and

$$P = \frac{1}{4} I_0^2 / (\omega C_s) \quad \text{at} \quad G_{\text{opt}} = \omega C_s \quad \text{for the probe .}$$

Calculating the corresponding cavity Q_{ex} from

$$Q_{ex} = \frac{\omega U}{P} \quad (13)$$

$$\Rightarrow Q_{ex} = \frac{2}{\mu_0} \frac{\iiint H^2 dv}{(\iint H ds)^2} L_s \quad Q_{ex} = \frac{2}{\epsilon_0} \frac{\iiint E^2 dv}{(\iint E ds)^2} C_s \quad (14)$$

loop probe

The volume integration is over the cavity volume.

From this formula we learn that for a given loop area the inductance L_s should be as small as possible. We carefully have to avoid inductance not linked to the cavity field and the loop conductor should have the biggest cross section compatible with other constraints. For probes in correspondence all capacitance which does not pick up cavity field is harmful.

But even with all precautions taken to minimize L_s or C_s , couplers with sufficient active area to satisfy our mode damping requirements have so much internal reactance (or susceptance resp.) that R_{opt} gets far away from the standard of 50Ω and the inherent simplicity of the approach gets lost.

3.3 Complex coupling port termination

More possibilities are opened up if one decides to terminate the coupling port by a *complex* load. Then around some selected frequencies one can *compensate* the internal reactance to obtain enhanced damping.

Take as simple example of compensation at one frequency a *probe* terminated by an admittance with *inductive* component.

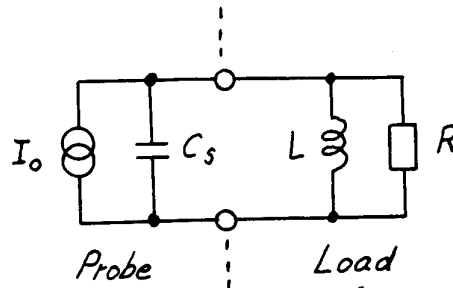

Choosing the right amount of inductance, $L = 1/(\omega^2 C_s)$, all the current I_0 must pass through R and increasing its resistance one apparently can increase dissipation (for a given U) and hence damping as much as one needs.

In this way, one can concentrate the effort on one mode but at the expense of other neighbouring modes. The bigger R the smaller the bandwidth within which the compensation is effective. At a certain limit, when the compensation bandwidth approaches the mode bandwidth, a more detailed view has to be taken.

In fact, the coupler itself is now a resonator with a quality factor $Q_c = \omega C_s R$ and coupled to the mode with some coupling factor k . To be rigorous, we have to apply coupled resonator analysis [7] which says that the maximal obtainable mode bandwidth is $\Delta f = k f$ at $Q_c = 1/k$. If the coupler's Q_c is made bigger than $1/k$ we don't get more bandwidth but mode splitting. As shown in Appendix 2, k can be calculated if a pair of values, Q_c (with $Q_c \ll k^{-1}$) and Q_{ex} is known

$$k^2 = \frac{1}{Q_c Q_{ex}}. \quad (15)$$

Let me now sum up the salient points of the complex port termination approach:

- (a) We may regard a probe, coupling to a mode with stored energy U , as equivalent to a current source I_0 shunted by a capacitance C_s .
- (b) A current source connected to an impedance Z generates a power $P = I_0^2 \text{Re}(Z/2)$.
- (c) Efficient mode damping requires to find a lossfree network which has the shunt capacitor C_s as first element and which transforms a load resistor of some convenient value (say 50Ω) into an input impedance Z with resonant character, i.e. its real part is made to peak at certain frequencies, selected to match the distribution of dangerous cavity modes.
- (d) In correspondence for a loop $P = V_0^2 \text{Re}(Y/2)$, where Y is the input admittance of a transforming network which has a series coil L_s as first element and is designed to peak the real part of Y at certain frequencies.

4. COUPLERS WITH RESONANCES

One could now dream of a computerized synthesis procedure which takes the mode frequency distribution and the required Q_{ex} values as input, calculates the equivalent quantities I_0 and C_s for a given probe geometry and position, selects a network structure and calculates its optimal element values.

Especially one item in this list is still very much in the realm of intuition and experience. It is the selection of a suitable network.

In fact, it has not only to provide resonances with the correct Q at selected frequencies but also has to suppress coupling to the fundamental mode which requires a zero of the real part of Z (or Y resp.) at the fundamental frequency. The notch must be

wide enough to allow pretuning of the fundamental mode suppression at room temperature but must not impair coupling to the HOM which are next to it (the TE₁₁₁ modes).

There are also non-electrical requirements. Simplicity of construction from Nb, straightforward cooling with liqu. He, demountability etc.

In the following, some possibilities are sketched going from simple to more complex and following in some way the development of ideas which led to the HOM couplers now in use here at DESY, at CERN and CEN-Saclay.

4.1 The $\lambda/4$ resonator

The simplest way to produce *several* coupler resonances is to use a *mismatched* line as connection to the load R. For a loop we have to choose $Z_0 < R$, for a probe $Z_0 > R$. The frequencies of compensation (resonances) are then near to the $\lambda/4$ resonance and its uneven multiples and their Qs are the higher the greater the chosen mismatch.

4.2 Splitting the $\lambda/4$ resonance

Unfortunately, this very simple compensation scheme does not fit the pattern of HOM found in present day storage ring cavities. We find a first group of dangerous modes (TE₁₁₁, TM₁₁₀) at about 1.4 times the fundamental and a second (TM₀₁₁, TM₁₁₁) at about 2 times, too near to each other to be covered by successive $\lambda/4$ resonances.

But we can split the fundamental resonance into two with the appropriate frequency difference if we add two reactances to the simple $\lambda/4$ circuit. As sketched below, a kind of band filter circuit is formed.

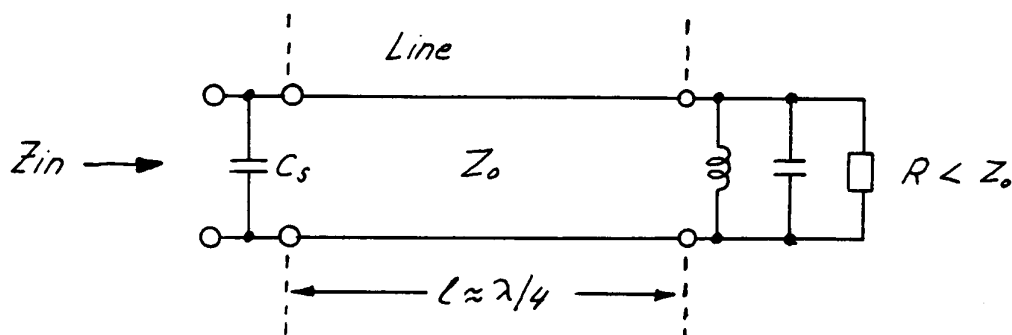

The added parallel resonator is tuned near to the first $\lambda/4$ resonance. Its impedance *locus* is a circle. The $\lambda/4$ line transforms into a double resonance.

This double resonance is retained if we put the load R in series with C and even if we connect a shunt coil L_1 across the front end of the coupler (provided its inductance is not too small).

With a series resonator filter added parallel to L_2 to suppress fundamental mode coupling, this is the basic scheme of the couplers [8] used on the HERA cavities. Also a 1.5 GHz version has been designed [9].

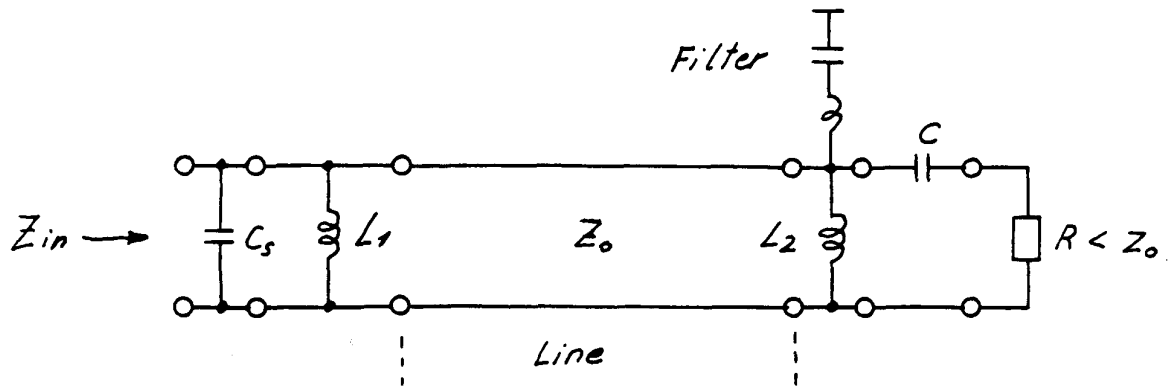

The demountable HOM couplers developed in the last three years in a collaboration between CEN-Saclay and CERN are close relatives of the HERA coupler. To achieve fundamental mode suppression and demountability they add a condenser in series with L_1 .

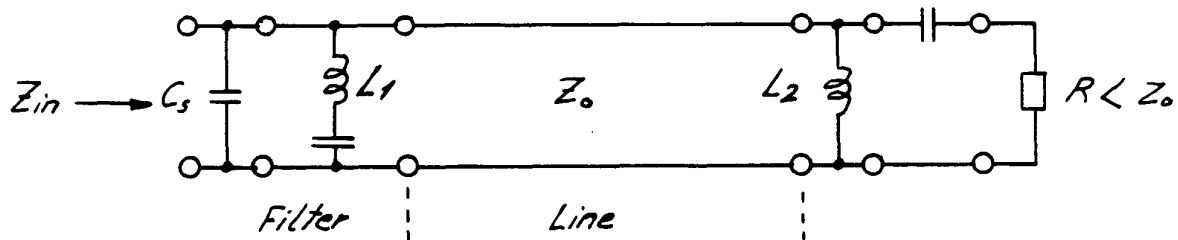

This scheme describes coupling to *electric cavity* fields but the advanced position of the loop formed by L_1 allows also *magnetic coupling* which contributes most to the *damping* of the TE_{111} mode family by interaction with its H_z fields. Admixture of magn. H_ϕ coupling also serves to compensate tuning errors of the fundamental mode suppression filter by turning the loop away from its nominal orientation perpendicular to the cavity axis.

Figure 3 shows the drawing of a prototype coupler recently manufactured in our workshops; (the small gap in the filter C avoids multipacting). Other versions already in operation are subject of a *poster* [10].

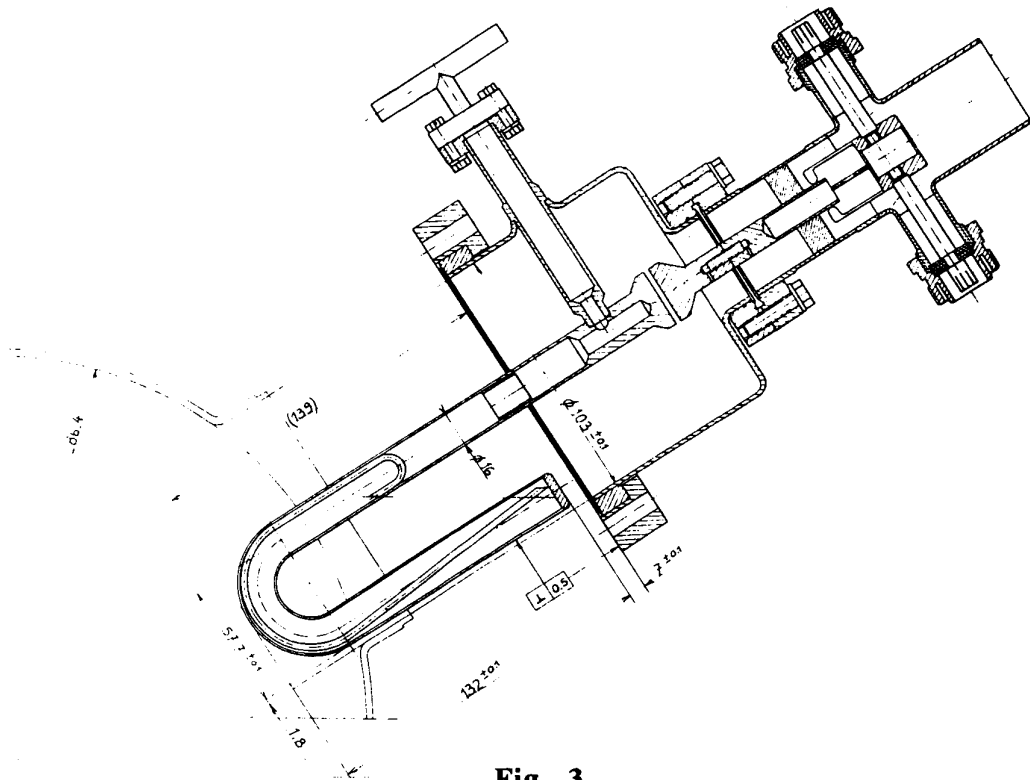

Fig. 3

4.4 Numerical computation

This approach to coupler analysis lends itself readily to make meaningful estimations of mode damping. One ingredient is a calculation of the couplers input impedance for probes (or admittance for loops) *including* into the network the couplers C_s (or L_s resp.)

The second ingredient is a calculation of the probe's short circuit current I_0 or the loop's open circuit voltage V_0 to first order by making use of a cavity code which gives the stored energy U and the fields E and H at the coupler's location. We assume that these fields are not too much perturbed by the presence of the coupler and estimate the fluxes.

$$I_0 = \omega \epsilon_0 \iint E \, ds \quad \text{or} \quad V_0 = \omega \mu_0 \iint H \, ds .$$

Then we calculate Q_{ex} from the defining equation $Q_{\text{ex}} = \omega U/P$ with

$$P = \frac{1}{2} I_0^2 \operatorname{Re} Z_i \quad \text{for probes ,}$$

$$P = \frac{1}{2} V_0^2 \operatorname{Re} Y_i \quad \text{for loops .}$$

Figure 4 shows both a measured and (in the insert) a calculated "sensitivity curve". The Real part of the input impedance Z_i is plotted against frequency.

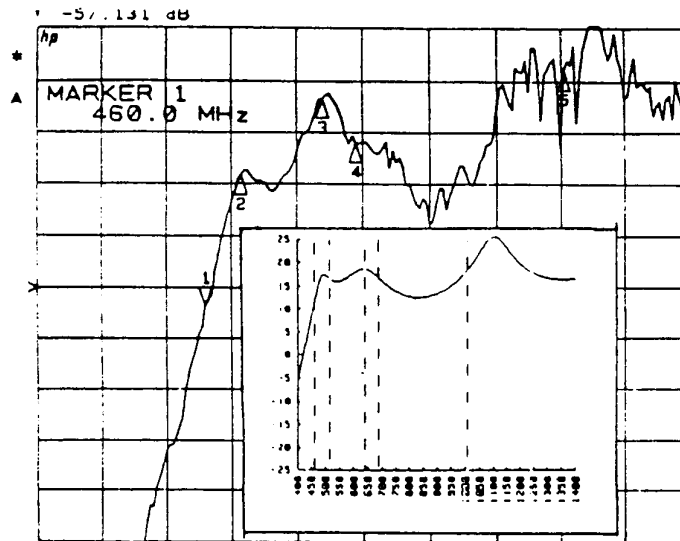

Fig. 4

Sensitivity curves are measured, as outlined in fig. 5, taken from a report [9] on the HERA couplers. We measure the transfer between a short probe (or small loop) inserted near to the coupling port and the coupler's load resistor. You see in fig. 4 the two "band filter" resonances and a third one, which is the second $\lambda/4$ resonance, all aligned with the dangerous mode families.

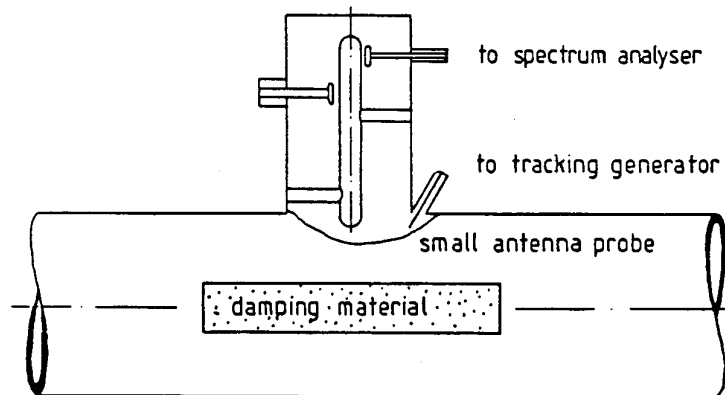

Fig. 5

As the last figure in this HOM part, here is a table of Q_{ex} measured with two new couplers on a LEP cavity. Compared to the previous standard HOM coupler, we improved damping action by a factor 4 to 5 and together with more sturdy connectors, feed throughs and cables we are prepared for a corresponding increase of current in LEP.

f/Mhz	461	476	506	513	639	688	1006
Mode	TE ₁₁₁	TE ₁₁₁	TM ₁₁₀	TM ₀₁₁	TM ₁₁₁	TM ₁₁₁	TM ₀₁₂
(R/Q)/Ω	18	15	20	13	56	25	16
Q _{ex}	17 000	14 000	5600	5700	7000	1000	2000

5. OTHER RECENT DEVELOPMENTS AND RESULTS

5.1 Developments for B factory use

From time to time we should remember that putting all couplers on the beam tubes must not get the status of a dogma.

This approach surely makes it easier to reach high Q and field but a penalty has to be paid. Each beam tube coupler forms an irregularity which is a source of wake fields and for high-intensity machines we have the conflicting requirements of tight coupling, i.e. big coupler dimensions and low wakes which asks for a smooth beam tube.

The Cornell team [11] works on a scheme which makes use of the beam tube for coupling and damping but aims at minimizing the wake effects. The resonance technique just described for HOM can obviously also be applied to input couplers but then to obtain a given matching Q_{ex} with a diminished coupling aperture. One pays with enhanced fields in the resonant parts of the coupler. But if these are made superconducting no significant increase of transmission losses will occur.

In the Cornell design the coupling iris itself forms the resonant part. A U-shaped slot [12] excited in a λ/4 resonance transfers energy between waveguide [13] and beam tube. At 500 KW power transfer the slot fields (E_{pk} = 6.5 MV/m, H_{pk} = 152 Oe) remain smaller than the cavity fields.

Couplers for HOM damping are avoided altogether. Instead a cell length made shorter than λ/2 to push the TE₁₁₁ frequency upwards and a beam tube with four ridges assure propagation of all HOM to ferrite tiles which shall absorb them [14].

5.2 Work on windows

At the time of this workshop room temperature windows are in general use where high powers have to be transmitted into s.c. cavities. They are all transplants from copper RF systems and come with a proven record of reliability. This is their main attraction which outweighs the risk of cavity contamination when they are mounted or changed.

The principal cause of window failure is excessive metal deposition on their vacuum side. This leads to inhomogeneous heating and the window finally breaks due to differential thermal stresses.

The most probable source of metal is sputtering from local glow discharges triggered by multipacting and gas desorption on the ceramic surfaces. To interrupt this vicious circle thin coating of the windows' vacuum side with a compound of low secondary emission is indispensable. Titanium or its Nitride are the materials of choice. In addition, careful and cautious preconditioning on a warm teststand is mandatory.

Clearly good cooling of the window must have a beneficial effect on its lifetime. Therefore, at DESY the suspension rings of the cylindrical LEP window have been redesigned replacing Kovar by Copper and shortening the thermal path length [15]. On a teststand 300 KW have passed this window as part of the doorknob transition between waveguide and coaxial coupler.

At Cornell the B-factory window will have to pass 500 KW of CW power. A waveguide window has been designed. Located outside the cryostate and made up of a water-cooled diaphragm with three BeO disk windows brazed to it its transfer characteristic is that of a band filter, flat within ± 5 MHz. High-power tests are imminent [16].

5.3 Adjustable power couplers

A problem of coupler construction identified only recently, since bigger numbers of cavities have been manufactured and operated, is an important scatter of the coupling factor for nominally identical cavities, much more than retraceable to geometrical tolerances of the couplers themselves. One probable cause is scatter of the field profile. But whatever the reasons, means to readjust the effective coupling of a cavity in a range 1:2 are needed.

Therefore, at DESY [17] the waveguide of the power feed system carries three cylindrical plungers in a mutual distance of $\lambda/4$. Their utility is twofold. Both coupling errors and phase errors of the feed system can be compensated within certain ranges.

There is another drawback of the present fixed coupling technique. The Q_{ex} for matching to the beam currents of present day storage rings are so much (3 to 4 orders of magnitude) smaller than the Q_0 of s.c. cavities that once the coupler is mounted Q_0 can no longer be measured by any RF method.

And if many cavities are enclosed within the same cryostate vessel fed by a refrigerator, also calorimetric methods to determine a specific cavity's dissipation and hence Q_0 do no longer work with the required precision. One of the key parameters of

cavity specification can no longer be verified when a cavity has become operational within a machine.

Therefore, if one reconsiders a coupler's construction in view of making it adjustable, one should try to obtain a range of four orders of magnitude in Q_{ex} . For beam tube antenna couplers as at present in use at KEK, DESY and CERN this requires a displacement of the antenna tip by about 150 mm.

A solution to this problem first devised in the frame of the SCRUNCHER project at Los Alamos [18] is sketched below.

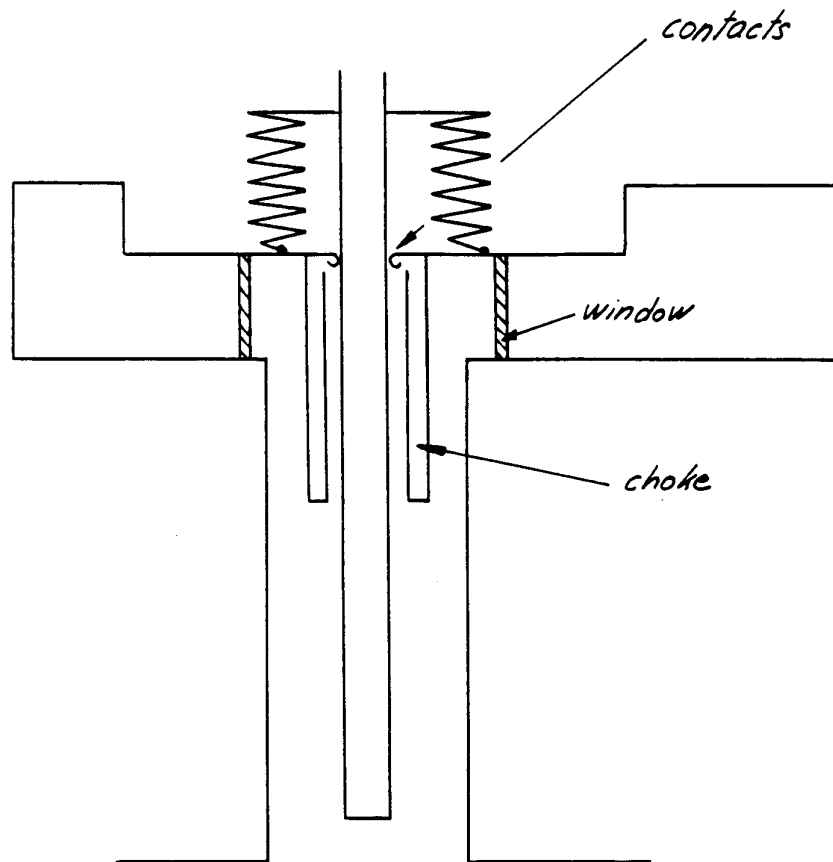

Basis is the LEP coupler concept [19] where a waveguide coaxial transition is the key element, supporting the cylindrical window and giving easy access to the antenna which passes via a fixed joint through the doorknob at the upper broad waveguide wall.

The essential modification consists in replacing the fixed joint by a sliding contact and in deviating the RF current away from it by a choke construction.

The SCRUNCHER coupler has been in operation for one year and has been tested up to 10 KW of incident power. Through a CERN version 185 KW have been passed on a warm conditioning stand. Tests on a cavity are imminent [20].

APPENDIX 1

THE GENERATOR POWER DEMANDS OF A MISMATCHED AND DETUNED SC CAVITY

Imagine a s.c. cavity has been matched at a certain voltage V and beam power P_{B0} , i.e. at P_{B0} the generator has to supply $P_G = P_{B0}$. But for smaller beam powers P_B , the match will be lost and $P_G > P_B$. Detuning the cavity will cause additional mismatch and even more generator power will be needed to keep V constant.

To determine P_G for these more general operating conditions, we first simplify the circuit of fig. 1 in two points. We notice that the source impedance seen by the cavity is independent of the transmission line length. Hence, we may choose a zero length. Further, we transform the generator to the accelerating gap of the cavity. We thus arrive at the circuit below made up only of *lumped* elements which allows to use standard circuit analysis.

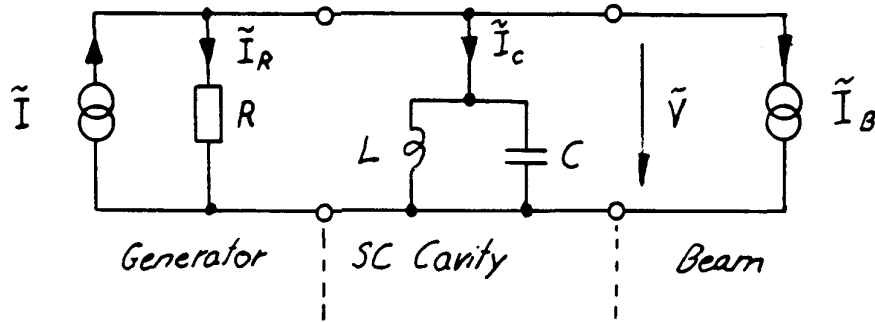

For this circuit $Q = R \sqrt{C/L} = n^2 Z_0 \sqrt{C/L}$. Comparing with the corresponding cavity expression, $Q_{ex} = n^2 Z_0 / (R/Q)$, we conclude that $\sqrt{L/C} = (R/Q)$.

I_B represents the in phase component of the RF beam current so that $P_B = V I_B/2$. A possible out of phase component is thought to be compensated by a pretuning of the cavity.

The generator power is defined as the power drawn by a load $R_L = R$. Here,

$$P_G = \frac{1}{2} \left(\frac{I}{2} \right)^2 R_L = \frac{1}{8} I^2 R. \quad (1)$$

To calculate the power P_G needed to produce P_B we use the node equation to express \tilde{I} by \tilde{I}_R , \tilde{I}_C and \tilde{I}_B .

$$\tilde{I} = \tilde{I}_R + \tilde{I}_C + \tilde{I}_B. \quad (2)$$

\tilde{I}_R and \tilde{I}_B have both the direction of \tilde{V} but the reactive current \tilde{I}_C is at right angles. So, eq. (2) corresponds to the phasor diagram.

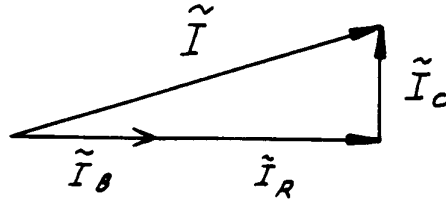

and
$$I^2 = (I_B + I_R)^2 + I_C^2 = I_R^2 + I_B^2 + I_C^2 + 2I_R I_B. \quad (3)$$

I_R and I_C are proportional to V : $I_R = V/R$ and $I_C = V Y$. Y is the susceptance of the detuned cavity.

$$Y = \sqrt{C/L} \frac{2 \delta f}{\delta f}. \quad (4)$$

Combining expressions

$$\Rightarrow P_G = \frac{1}{8} \left(\frac{V^2}{R} + I_B^2 R + (VY)^2 R + 2 V I_B \right). \quad (5)$$

For a tuned cavity ($Y = 0$) we find as condition for minimal P_G (varying R)

$$R = V/I_B. \quad (6)$$

And as minimal generator power

$$P_G = \frac{1}{2} V I_B = P_B. \quad (7)$$

Assume now we have chosen $R = R_0 = V/I_{B0}$ but pass a beam current $I_B = m I_{B0}$ through the cavity.

Then from eq. (5) in replacing R by $R_0 = V/I_{B0}$ and dividing by $P_{B0} = V I_{B0}/2$

$$\Rightarrow \frac{P_G}{P_{B0}} = \frac{1}{4} \left(1 + m^2 + (R_0 Y)^2 + 2m \right). \quad (8)$$

But
$$R_0 Y = R_0 \sqrt{C/L} 2\delta f/f = 2Q_{ex} \delta f/f = 2\delta f/\Delta f. \quad (9)$$

Here Δf is the 3 dB bandwidth of the cavity. Using further $m = I_B/I_{B0} = P_B/P_{B0}$

$$\Rightarrow \frac{P_G}{P_{B0}} = \frac{1}{4} \left(1 + \frac{P_B}{P_{B0}} \right)^2 + \left(\frac{\delta f}{\Delta f} \right)^2. \quad (10)$$

APPENDIX 2

Let a mode at ω be damped by a resonant and optimally tuned coupler, i.e. $\omega_c = \omega$. Let the coupler have $Q_c = \omega C_c R$ and the mode have Q_{ex} . What is the coupling factor k ?

We use the equivalent circuit below. L_m and C_m represent the mode resonance and C the coupling. Then, $k^2 = C^2 / (C_m C_c)$.

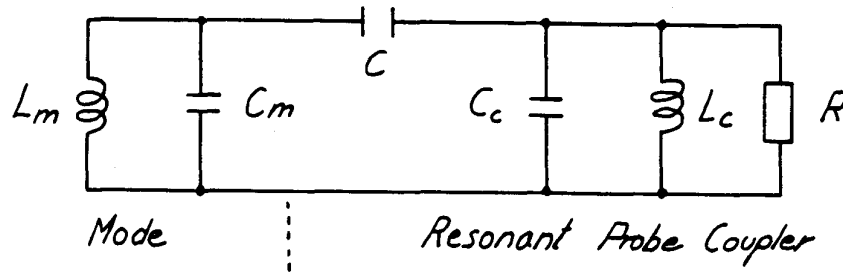

Let R be chosen small enough to make $Q_c \ll Q_{ex}$. Then, within the mode bandwidth the coupler circuit has a practically constant impedance equal to R and one can simplify:

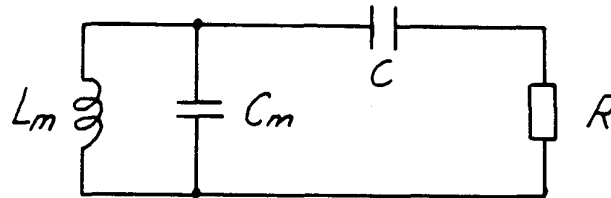

For small coupling $R \ll 1/(\omega C)$, and we find as the parallel equivalent of C and R

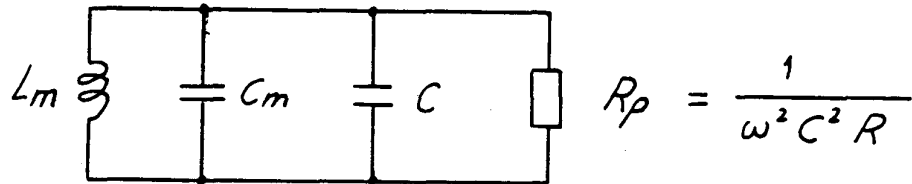

And the quality factor of this circuit is

$$Q_{ex} = \omega (C_m + C) R_p \approx \omega C_m R_p,$$

$$Q_{ex} = \frac{\omega C_m}{\omega^2 C^2 R} = \frac{C_m C_c}{C^2 \omega C_c R} = \frac{1}{k^2 Q_c},$$

$$\Rightarrow k = \frac{1}{\sqrt{Q_{ex} Q_c}}.$$

REFERENCES

- [1] K. Mittag, H.A. Schwettman and H.D. Schwarz, IEEE Trans.Nucl. Sci., NS-20 (1973) 86.
- [2] A. Mosnier, proc. of the 4th Workshop on RF superconductivity, ed. Y. Kojima, KEK (1989) 377.
- [3] E. Haebel, proc. of the 4th Workshop on RF superconductivity, ed. Y. Kojima, KEK (1989) 501.
- [4] K.W. Robinson, CEA, Report CEAL-1010 (1964).
- [5] K. Ebihara et al., KEK preprint 89-121 (oct. 1989) and XIV Int. Conf. on High-Energy Accelerators, Tsukuba (1989).
- [6] D. Boussard, CERN/SPS 85-31 (ARF) and PAC, Vancouver (1985).
- [7] W. Schminke, CERN/SPS/ARF/WS/GS 81-68 (1968).
- [8] E. Haebel and J. Sekutowicz, DESY, M-86-06 (July 1986).
- [9] J. Sekutowicz and Chen Yinghua, proc. of the 4th Workshop on RF superconductivity, ed. Y. Kojima, KEK (1989) 615.
- [10] Ph. Bernard et al., this workshop.
- [11] H. Padamsee et al., this workshop.
- [12] L. Szecsi, KFK, Primarbericht (August 1978).
- [13] H. Padamsee et al., CLNS 91-1076.
- [14] D. Moffat et al., CLNS 91-1072.
- [15] B. Dwersteg, private communication.
- [16] J. Kirchgessner et al., CLNS 91-1064.
- [17] B. Dwersteg, proc. of the 4th Workshop on RF superconductivity, ed. Y. Kojima, KEK (1989) 593.
- [18] J. Davis et al., to be published in Nucl. Instr. and Methods.
- [19] E. Haebel, proc. of the 2nd Workshop on RF Superconductivity, Geneva (July 1984) 299.
- [20] Ph. Bernard et al., this workshop.