

New Ways of Cavity Fabrication

Dieter Proch

Deutsches Elektronen-Synchrotron DESY
Notkestraße 85, 22603 Hamburg, Germany

Abstract

Nb cavities are fabricated from sheet material by deep drawing (or spinning) of cups and subsequent welding at the small and large diameter. A fabrication technique without the need of welding would substantially reduce fabrication costs and eliminate defects related to the welding process. This paper summarises the effort at different laboratories to find a technique for seamless cavity production.

Introduction

Presently niobium cavities are fabricated by the following steps:

- forming of cups by a deep drawing or spinning process of the Nb sheet material
- trimming of the weld areas at the equator- and iris region
- e-beam-welding at equator and iris of one cell
- repetition of the above welding to form a multicell cavity. By adequate tooling a multicell structure could be welded in one shoot.
- e-beam welding of the stiffening ring at the iris region. This is needed for very high gradient cavities in order to suppress the effect of the Lorentz force.

Fig. 1 shows a picture of the first two 9-cell cavities (1,3 GHz) for the TESLA [1] (TeV Superconducting Linear Accelerator) Test Facility (TTF) at DESY.

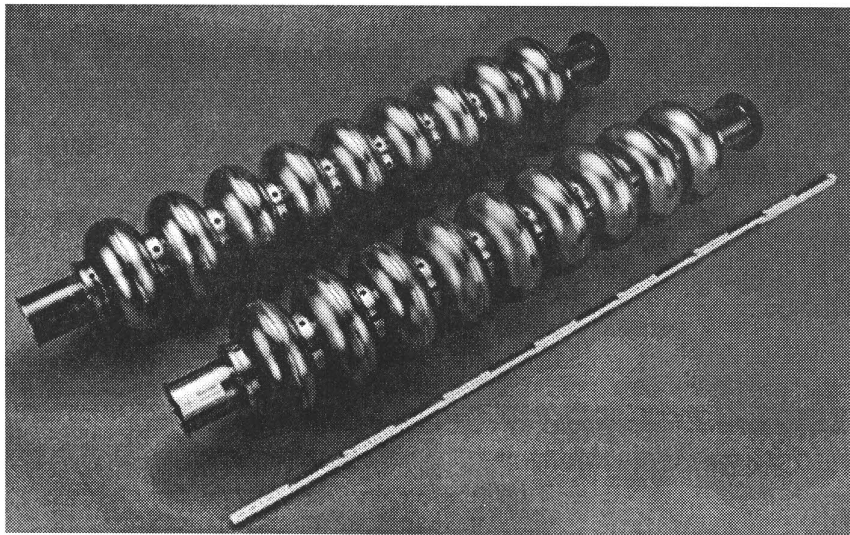

Fig. 1 9-cell cavity for TTF as example of Nb cavity production

The inner cavity surface is sampled by the RF current. Therefore the inner weld bead has to be of high quality. This can be assured by using inside welding which is a complex procedure for multicell cavities. Outside welding is easier but is more critical in welding parameters. Therefore a fabrication technique without the need of welding is favourable in respect to costs and fabrication errors.

Furthermore the absence of a weld eliminates the risk of a RF breakdown at a weld defect.

From 6 to 8 March, 1995 a workshop about "New ways of cavity fabrication techniques" was held at DESY. The issues of this workshop were as follows:

- report about past experiments,
- discuss the understanding of success or failure,
- collect all available information about metallurgical properties of niobium,
- review principal fabrication methods,
- report/discuss present activities in development of new fabrication methods,
- have time to brainstorm on new ideas,
- organise/coordinate joined effort in different labs of companies.

In total 49 attendees from 12 institutes and 7 companies joined this meeting. A collection of the view graphs presented on this occasion is available in [2]. In this paper the outcome of this workshop is reported and new developments since then are summarised.

1. Niobium material parameters

Most Nb material for cavity production is delivered as sheet material of 2 to 4 mm thickness. The Nb has been cold worked during fabrication to an amount of 95 %. The internal stress is relaxed by a recrystallization treatment at 800 °C. The grain size typically is ASTM 4-5. The impurity content of dissolved gases is in the 10 to 50 ppm range (for C, N, H, O) and results in a typical RRR value of 250. Further cleaning can be done by a Ti getter process at 1400 °C for 4 h [3].

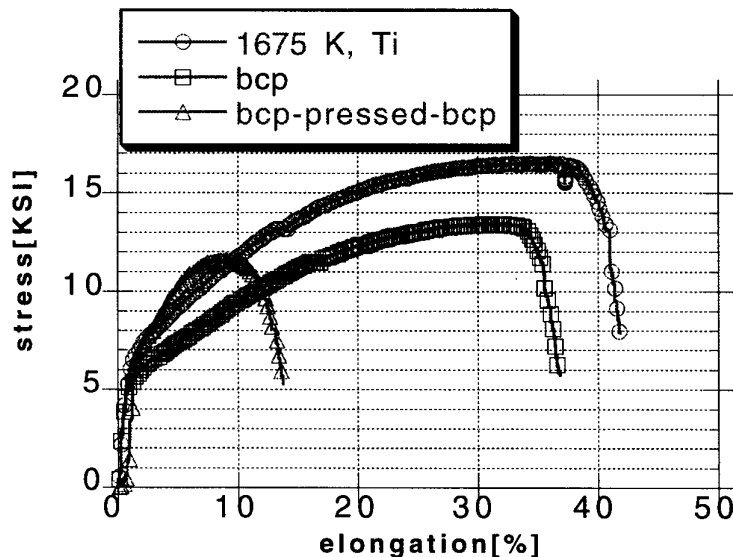

Fig. 2 Tensile measurement of Nb after different treatments [4]

The mechanical properties of a metal can be evaluated by a tensile measurement. Characteristic numbers are yield stress $\sigma_{0.2}$, tensile strength and maximum elongation. These numbers vary with treatment of niobium like chemical polish, pressing or heat treatment. Fig. 2 gives typical curves for tensile measurements of niobium. Although data vary from sample to sample, the following properties can be expected for high purity niobium (RRR = 250):

- The yield stress $\sigma_{0.2}$ of a sheet metal "as delivered" is around 50 N/mm². This value increases by a factor of ten at cryogenic temperatures. After heat

treatment at 1400 °C (post purification by Ti solid state getter process) the yield stress is considerably reduced. The onset of plastic deformation starts around 5 N/mm² [5].

- The maximum elongation varies from 20 to 50 %.
- After firing the Nb material is very soft so that special care has to be taken during handling a cavity.

Many mechanical and electrical data of niobium for cavity production have been measured and /or collected at CEBAF [4] and Saclay [6]. It is planned to establish a data bank for easy access.

2. Forming Techniques

2.1 Super plastic forming

Ordinary metals show little dependence of flow stress on forming rate. Under certain conditions particular alloys show "super plastic" behaviour: very little force is sufficient to achieve extremely high elongation as long as the forming velocity is low enough. For example a total elongation as high as 1000 % can be reached for Pb-Sn alloys [7]. Super plastic forming of complex geometries is a production process for example in aircraft industries.

The deformation mechanism in cold forming can be understood as dislocation gliding and twinning. This will result in shear and shape changes of the individual grains. The super plastic forming is explained by sliding of grains relative to each other along grain boundaries. Therefore no major shape change of the grains happen. The thinning behaviour of a specimen will be uniform over its whole length, independent of the local cross section. For practical application it should be noted that the super plastic forming process takes place

- at high temperatures (> 50 % of melting temperature)
- low strain rates (> 10⁻³ s⁻¹)
- low flow stresses (< 10 MPa)

There was a recent indication in Russian literature [7] that niobium might have super plastic forming behaviour. If this is true a single step forming process from tube to multicell structures would be possible. The remaining difficulty is to avoid contamination (by O, N, C) of the niobium which is at high temperatures.

The possible super plastic behaviour can be extrapolated from tensile measurements with variation of the strain rate at high temperatures. In case of a positive result of these measurements further activities with a super plastic forming experiment might be launched.

2.2 Hot forming process

Experiments with a hot forming process were carried out at Cornell in 1983 [8]: a Nb tube was placed in a vacuum container and heated by electric current. The Nb tube was connected to an outside gas supply. With increasing gas pressure the tube could be formed into a bubble. In total, 20 tests were done between 400 °C and 1500 °C. The results can be summarised as follows:

- below 1200 °C all tests failed (rupture) before 50 % diameter increase; much orange peeling occurred; the pressure needed to be increased as the diameter

increased (because the work hardening was not sufficiently annealed out at $T < 1200\text{ }^{\circ}\text{C}$)

- above $1200\text{ }^{\circ}\text{C}$: the tubes expanded continuously, but experimental problems did not allow to sustain high temperatures long enough.
- at $1500\text{ }^{\circ}\text{C}$ near 100 % diameter expansion was achieved with no orange peeling

It was concluded that a 3:1 desired expansion (to make a cavity from a tube only by expansion) could be done. For further tests the furnace needs improvements. Dies (not even addressed yet) need development.

2.3 Explosive forming

Explosive forming has been tried out at several laboratories: Cornell [9], INFN Legnaro [10] and at KEK [11]. The starting tube is enclosed in an outer tool and completely immersed into water. The explosive power is varied to find best operating conditions. Recent experiments at KEK with Cu (see Fig. 3) demonstrated that a 50 % diameter increase could be gained without rupture. More experiments are planned with intermediate tools. At Cornell several Nb tubes were formed by explosive techniques. The maximum diameter increase without rupture was only 20 %. Similar negative results were experienced at INFN Legnaro. In conclusion: Explosive forming is a simple fabrication process. The drawback is, that there is no control during forming and that rapid cold work might reduce the maximum elongation.

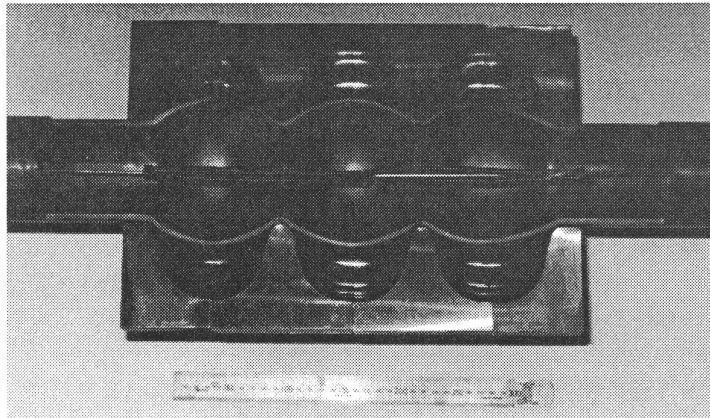

Fig. 3 Cut of a tube and a tool after first explosive forming into a 3-cell cavity [11].

2.4 Spinning

Spinning is a widely used fabrication technique to produce metal pieces of rotational symmetry. The principle forming action is shown in Fig. 4. In order to make cavities by this method, two principle problems have to be solved:

- a after shaping the maximum diameter the metal has to be "bend over" to form the small diameter at the iris region,
- b the mandrel has to be removed through the small iris diameter.

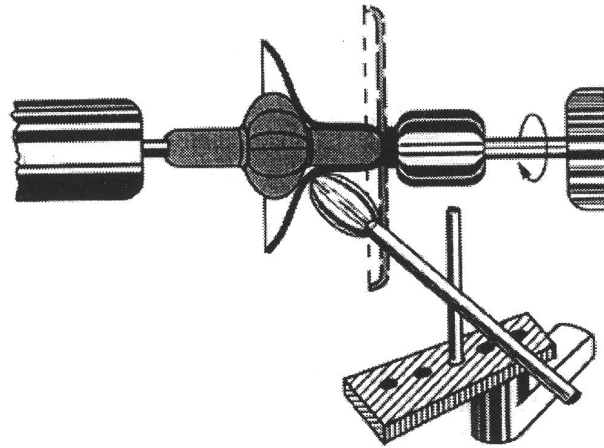

Fig. 4 Principle of spinning technique.

For the first problem crinkling and too much thinning must be avoided by choice of proper working parameters.

The second problem can be solved by a mandrel which is chemically dissolved after spinning. Another solution is the use of a mandrel which can be disassembled into small pieces.

At INFN Legnaro many experiments with spinning have been carried out [12]: single cell and ten cell structures from Al (see Fig. 5), three cell cavities from Cu and single and two cell cavities from Nb. The latest Nb cavities could be formed without intermediate annealing. Furthermore, the ratio of thickness variation could be reduced to less than 20%. The spinning process is manually controlled but could be customised by a computer controlled hydraulic system for mass production. The remaining uncertainty is whether the heavily deformed niobium has reduced mechanical (cracks, laminations, etc.) or electrical (locally reduced superconducting properties, bad thermal conductivity, etc.) properties. Therefore the first cold measurement of such a cavity will give an answer to these questions.

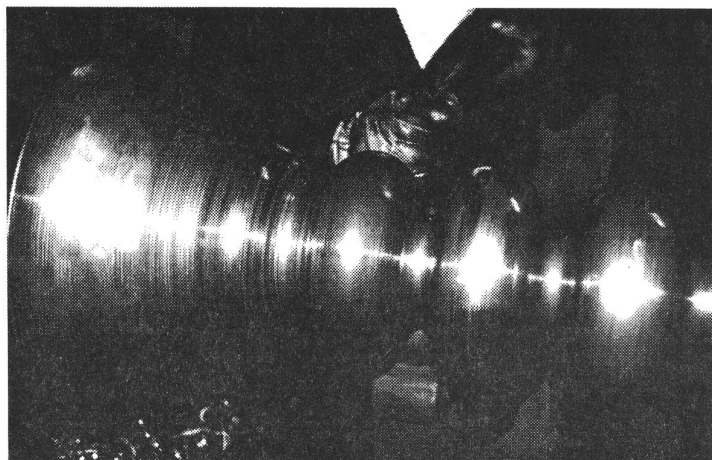

Fig. 5 Forming a multicell Al cavity by spinning [12]

2.5 Hydroforming

The principle hydroforming process is demonstrated in Fig. 6. The inner volume of a pipe is loaded with hydraulic pressure so that the diameter is expanded and finally fits into the outer die. It is important to support the radial expansion by an axial force which squeezes the pipe at the same time. The magnitude and the time development of the hydraulic pressure and the axial force are critical parameters for maximum expansion. Fortunately the stress during forming can be simulated by programmes (like ANSYS [13]) so that optimum parameters can be determined beforehand. Nevertheless experiments are necessary to see the influence of anisotropic material parameters and the consequences of defects in the material.

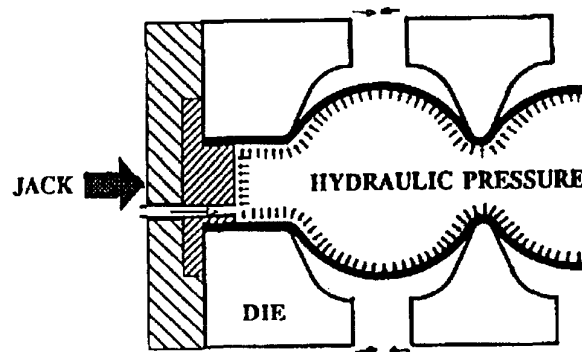

Fig. 6 Principle of hydroforming a cavity from a tube: the hydraulic inner pressure extends the tube diameter, the axial force supports the flow of material from small to large diameter.

2.5.1 Experience at CERN

At CERN many multicell cavities have been fabricated from Cu [14]. They were used for sputter coating of the inner surface by a thin ($\sim 30 \mu\text{m}$) film of Nb. The size ranged from diameter 740 mm (360 MHz) to 130 mm (2 GHz). Two to three intermediate annealing steps were needed. A first test with a Nb tube failed due to early rupture (longitudinal crack along line defects from the extrusion process). No further tests were tried out because of lack of appropriate seamless tubes.

2.5.2 Experience at Cornell

Single and two cell cavities have been hydroformed from Nb [15]. Multiple stages were required to avoid the lateral instability of the tube as axial force was applied. They found six stages to be satisfactory with two intermediate anneals. Cryogenic tests resulted in average performance data. These activities were stopped because of progress in welding techniques and of difficulties to acquire seamless Nb tubes of small, uniform grain size.

2.5.3 Experience at DESY/INR

A hydraulic machine is under construction to form 9 cell cavities of the TESLA shape (see Fig. 7). This work is carried out in the frame of a collaboration between DESY and INR (Institute of Nuclear Research, Moscow). The difference of this approach as compared to the efforts described above is:

- The diameter of the tube is considerably larger than the smallest iris

diameter. The tube will be swaged at the iris region and enlarged at the equator. The tube diameter is chosen to equalise to material deformation for swaging and expanding.

- There are different methods to swage the iris regions. Electromagnetic forming has been tried out successfully with Cu tubes. In this method a capacitor is discharged by a coil which is placed around the tube. The Lorentz force of the induced current and the magnetic field deform the tube without mechanical contact.
- The ratio and the time development of axial and radial force is optimised with the ANSYS [13] code for maximum elongation. These parameters as well as the forming of the tube will be monitored during the expansion of the tube. Furthermore a process controller will regulate these parameters.

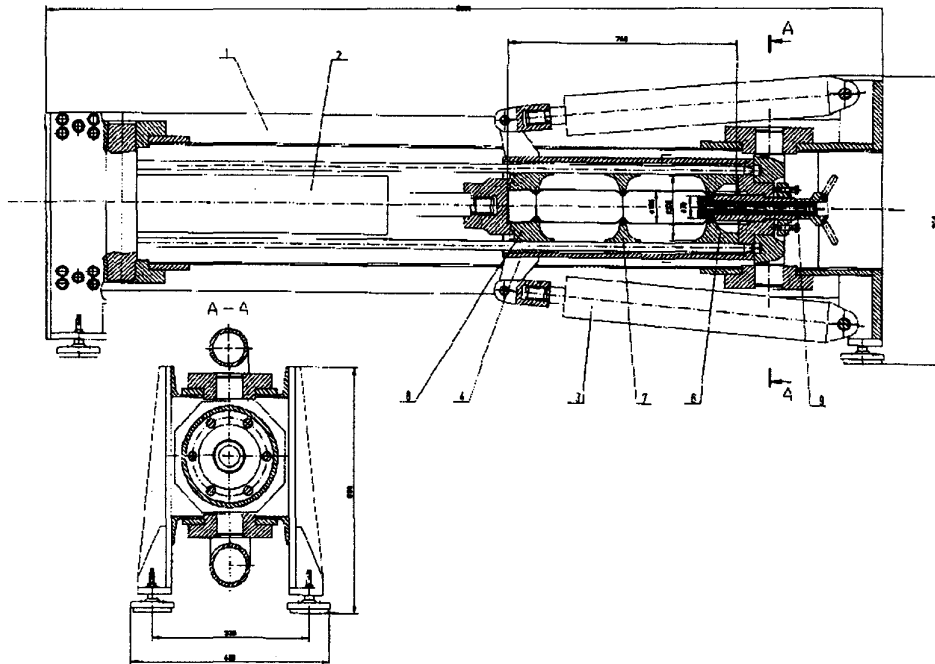

Fig. 7 Layout of a tool to hydroform multicell Nb cavities (DESY/INR, Moscow)

2.5.4 Experience at Butting Company

Butting is a company which produces longitudinal welded pipes, elbows and vessels out of stainless steel. They operate a calibration press with 10000 KN tools force and a water press for hydroforming with 2500 bar. This company started a series of experiments to fabricate cavities by hydroforming using their infrastructure. Recently they have produced a 2-cell cavity (TESLA shape) from Cu without an intermediate anneal [5]. First experiments with Nb tubes have been started.

2.6 Seamless tubes for hydroforming

Past experiments with hydroforming failed because of lack of suitable tubes. Several ways of tube production have been discussed:

- Rolling and longitudinal welding. This is not a seamless tube, but it could be a simple alternative if the welded area is treated to gain uniform grain size again. Grinding, hammering and annealing seems to be a reasonable

procedure. Those tubes are under fabrication at DESY and will be tested soon.

- Spinning a tube from sheet material. This fabrication method was proposed by Palmieri and will be tried out in the near future.
- Cold extrusion. In this method a pellet of niobium is squeezed between an inner (stamp) and outer (cylinder) tool. With the right parameters of stamp velocity and -force, the Nb will flow into the gap between cylinder and stamp. Using this method seamless tubes of a diameter of 70 mm, wall thickness of 3 mm and length of 110 mm have been produced by W.C. Heraeus for the beam pipes at the TESLA cavities. After recrystallization at 800 °C the material parameter of the starting material (RRR, grain size) could be recovered. Larger tubes (diameter, length) can be produced by cold extrusion but need some investment in tooling.

3. Summary

Fabrication methods like spinning, hydroforming and explosive forming are possible techniques for a seamless cavity production. Explosive forming needs intermediate annealing steps whereas hydroforming most likely could do it without. Activities have been started at different laboratories and companies. First tests with Cu forming gave encouraging results. In both cases a seamless tube with uniform grain size is needed to start with.

Spinning was used to produce multicell structures from Cu and Al and single cells from Nb without intermediate anneal. First cold tests are planned in the near future.

Acknowledgment

Exchange of information and fruitful discussions with my colleagues from the SRF community is gratefully acknowledged.

References

- [1] TESLA Design Report, Editor D. Edwards, TESLA-Report 95-01
- [2] TESLA-Report 95-09
- [3] P. Kneisel, J. Sess, Common Metals, 139; p. 1789 (1988)
- [4] M. Rao, CEBAF, private communication
- [5] H. Kaiser, DESY, private communication
- [6] B. Bonin, Saclay, private communication
- [7] Schleinzer, Dornier GmbH, private communication
- [8] C. Henderson, Cornell University, SRF note 830201
- [9] J. Kirchgessner, Cornell University, SRF note 820905
- [10] V. Palmieri, INFN Legnaro, private communication
- [11] K. Saito et al, Proc. of PAC 95
- [12] V. Palmieri et al, Proceedings of EPAC94, p. 2212
- [13] ANSYS User's Manual, Vol. 1, Swanson Analysis Systems Inc., 1992
- [14] C. Hauviller, IEEE 1989 PAC, p.
- [15] J. Kirchgessner, Cornell University, private communication