

WIDEBAND CURRENT TRANSFORMERS FOR THE SURVEILLANCE OF THE BEAM EXTRACTION KICKER SYSTEM OF THE LARGE HADRON COLLIDER

C. Defrance, J. Bergoz, Bergoz Instrumentation, 01630 Saint-Genis-Pouilly, France
L. Ducimetière, E. Vossenber, CERN, Geneva, Switzerland.

Abstract

The LHC beam dumping system must protect the LHC machine from damage by reliably and safely extracting and absorbing the circulating beams when requested. Two sets of 15 extraction kicker magnets form the main active part of this system. A separate high voltage pulse generator powers each magnet. Because of the high beam energy and the consequences which could result from significant beam loss due to a malfunctioning of the dump system the magnets and generators are continuously surveyed in order to generate a beam abort as soon as an internal fault is detected. Amongst these surveillance systems, wideband current transformers have been designed to detect any erratic start in one of the generators. Output power should be enough to directly re-trigger all the power trigger units of the remaining 14 generators.

The current transformers were developed in collaboration with industry. To minimize losses, high-resistivity cobalt alloy was chosen for the cores. The annealing techniques originally developed for LEP beam current measurement in collaboration between CERN and industry allowed to extend the frequency response beyond that of traditional core materials.

The paper shows the results obtained, exposes the problems encountered with shielding, conductor position sensitivity, load resistor technology and their solutions.

The know-how acquired during the collaboration was further applied by the industrial partner to cover a wider range of sensitivity, size and frequency.

INTRODUCTION

The LHC beam dump system is a safety system that must protect LHC machine components from damage due to excessive beam losses, or personnel from radiation hazards. Failing to respond to dump requests has severe consequences. The functional operation and the required reliability of functioning are described in the LHC design study [2]. An important ingredient in terms of reliability and safety is the dual branch generator with two parallel 30 kV semiconductor power switches. For a correct dump action the 15 generators are all fired at the same time and are synchronised with the 3 μ s abort gap in the beam.

In case of an accidental un-triggered discharge of one of the generators beam would be deflected into the collider vacuum tube and cause severe damage to machine components. Therefore, in this event the other 14 generators are triggered automatically within 700 ns to

deflect the beam into the extraction channel and dump it safely on the absorber block.

BEAM EXTRACTION KICKER SYSTEM

The circuitry of the dual branch generator is shown in Fig. 1.

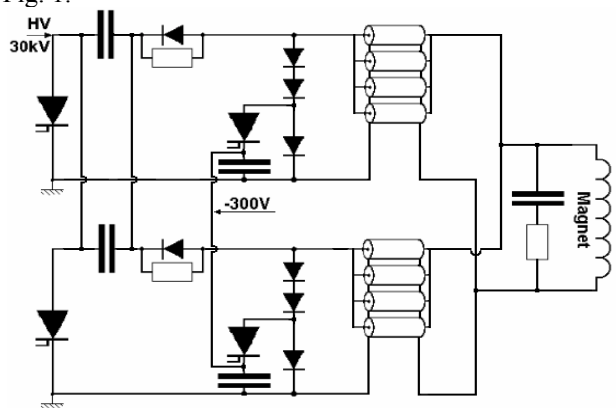

Figure 1: Dual branch generator circuit layout.

It consists basically of a discharge capacitor in series with a 30 kV semiconductor solid state switch, that produces in combination with a free-wheel diode stack parallel to the magnet a current pulse of 2.7 μ s rise time and about 2 ms fall time, of which only 95 μ s are used to empty the machine. After the magnet current has reached its peak amplitude the polarity of the generator inverses and the freewheel diode stacks start to conduct the magnet current. Simultaneously the 2.5 kV current droop compensation switch, which is connected in series with a 3.25 mF, -300 V capacitor, is closed and the current in the fast recovery diode is commutated. The 3.25 mF capacitor is then connected in series with the magnet inductance and oscillates with a superimposed half-sine wave, which compensates for the resistive losses of the magnet current freewheel circuit.

The generator capacitor voltages are tracked with the beam energy between 2.2 kV at 450 GeV and 30 kV at 7 TeV. The main parameters are listed in Table 1.

Table 1. Main generator parameters.

Voltage range	2.2-30 kV
Peak magnet current (7 TeV)	18.5 kA
Peak magnet current (450 GeV)	1.29 kA
Magnet current flat top 100-105%	95 μ s
Current rise time 0-100%	2.7 μ s
Repetition time, minimum	30 s

SPECIFICATIONS FOR THE CURRENT TRANSFORMERS

A re-trigger system (RTS) must immediately re-distribute a trigger request, arising from a spontaneous firing of one of the four solid state switches in one generator, to the remaining 14 generators. Therefore, a set of two redundant current transformers (CTs) is mounted in each of the 30 kV semiconductor power switches and 2.5 kV droop compensation switches. The CTs detect any un-triggered generator discharge by measuring the conduction of any of the switches. They have enough powering capabilities to trigger the power trigger modules of the 14 other generators.

Fig. 2 shows the re-trigger CTs in the 30 kV main switch and Fig. 3 the CTs in the compensation switch.



Figure 2: Re-trigger CTs in the main discharge switch.



Figure 3: Re-trigger CTs in the droop compensation switch.

The eight CTs of each generator are connected to a common re-triggering box, which is located in the same generator. The output of each re-triggering box is connected to the input of the trigger units of all other generators. A chained input/output system has been

chosen instead of a star system because it is faster. Since each CT has enough energy to trigger all power trigger modules, there is no stored energy in the system itself. This minimizes the risk of creating spurious triggers, even when a cable is being disconnected or a trigger source is defective.

Due to the large dynamic range of the LHC beam energy and consequently also of the generator charging voltages, the re-triggering action of the CTs is particular critical at the lowest beam energy (450 GeV) and corresponding low charging voltages. For reliability reasons it was decided to use SMA output connectors. Droop specifications are not an issue; re-triggering takes place on the rising edge of the measured signal. The outer shield (case) of the CTs is only grounded at the input of the re-trigger box. The main specifications of the re-trigger CTs are listed in Table 2.

Table 2. Specification of the RTS current transformers (type CT1: main switch; type CT2: compensation switch).

Type	CT1	CT2	
Inner diameter	38		mm
Outer diameter	72		mm
Thickness	17		mm
Sensitivity, 50 Ω terminated	0.5	2.0	V/A
Accuracy, 50 Ω terminated	±1		%
Maximum CT current (7 TeV)	2400	177	A
Minimum CT current (450 GeV)	152	15	A
Minimum ampere-seconds	10	1	mAs
Maximum rise time response	50		ns
Repetition time, minimum	30		s

CT DEVELOPMENT

The development process was driven by requirements of the LHC: these being high reliability, small size, stability with respect to time and temperature variations, low loss, accuracy of the transfer function, independence of the core magnetic state left by a previous primary pulse. Cobalt-based alloy was chosen for its high electrical resistivity and modest annealing temperature. This choice was also based on the extensive experience with, and equipment for, this type of alloy by our industrial partner.

The annealing temperature, rate of cooling, magnetic field intensity and vector direction allow a full control over magnetic core parameters such as lower cut-off frequency (droop), higher cut-off frequency (rise time) and coercive field H_c . To achieve the same performances for unipolar and bipolar pulses, H_c has to be as low as possible, in order to keep the maximum I-t value constant and independent of the residual core state.

The high electrical resistivity minimises losses in the core and the modest annealing temperature allows alloy processing in a laboratory environment.

To minimize core memory effects due to a previous primary pulse, the cores were annealed above the alloy Curie temperature in a fixed magnetic field and cooled at a controlled rate. This keeps the coercive field to a minimum value.

The power rating and pulse withstanding requirement dictated the choice of film resistors for the 50 Ω internal load. Chip resistors with substantial pulse withstanding characteristics are now available in a wide range of sizes, tolerances and values. These resistors have been successfully tested at CERN with 7 kW peak power and energy >3 mJ.

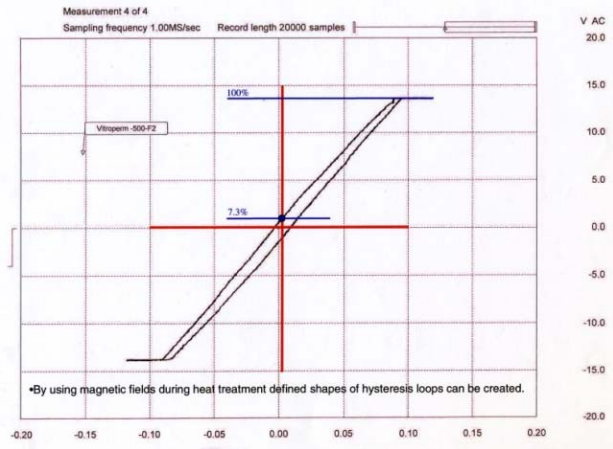

Figure 4: Magnetic core hysteresis cycle after annealing process and thermal treatment-Hc=7.3%.Bs.

The CTs are encased in a copper shield to minimise electrostatic pick-up and also to protect against interference from other sources. A gap is needed to avoid shorting the magnetic core. This gap presents a capacitance and acts as a low pass filter with a cut-off frequency inversely proportional to the gap width. To optimise the high frequency coupling, the gap width has been simulated and numerically analysed.

High frequency performance is obtained by keeping stray capacitance to a minimum. This implies the use of a small number of turns, yet enough to assure a uniform field distribution around the magnetic core.

A straightforward method to characterise CTs is to observe its transfer function in frequency domain. Calibration with an accuracy better than ±1% for the input/output ratio and ±0.1° for the phase is possible with a vector network analyser (VNA).

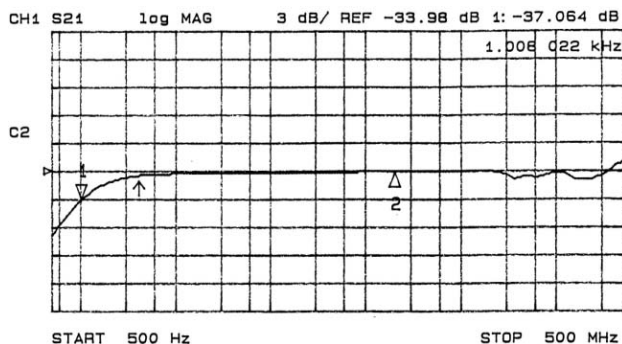

Figure 5:CT-36-2.0 V/A bandwidth (with 8751A Agilent VNA).

The nominal turns ratio value of CT-36-2.0 V/A is 25:1; this leads to 33.979 dB attenuation in the VNA 50 Ω input

port. Hence, all values in the range 34.067 to 33.893 dB meet the +/-1% accuracy criteria. Ratio error is mainly due to the resistor precision. Rise time and droop of 700 ps and 0.63%/μs respectively are deduced from the -3 dB higher and lower cut-off frequencies; these being 500 MHz and 1.008 kHz respectively. In reality, the -3 dB higher cut-off frequency is well in excess of 500 MHz therefore not measurable with this VNA.

The last two years have yielded significant progress on CTs which can now be calibrated within ±0.5% accuracy. Their output dependency on the primary conductor position due to non-uniform field density distribution in the magnetic core has been considerably reduced. Sensitivity to high voltage has been also reduced by improving the electrostatic shielding.

CONCLUSION

A fault tolerant re-trigger system for the LHC Beam Dump System has been developed and built. It powers immediately all magnets in case of spontaneous discharge in one of the generators. Wideband current transformers form an essential part of this system.

Two different wideband current transformers have been developed, built and successfully tested for use as surveillance systems in the LHC beam dumping system. The main design criteria were reliability, minimum coercive field and case size.

The developments led to a range of technical solutions for current measurement from micro-amps to 20 kA, at frequencies from 0.5 Hz to 500 MHz and sensitivity from 0.05 V/A to 5 V/A, providing environmental application flexibility. These CTs can be used in various applications such as laser and plasma research, semiconductor gate switching, capacitor and electrostatic discharges, corona wire discharge or partial discharge measurement.

With sensitivities up to 5 V/A and assuring faithful rendering of fast transients, CTs overcome critical measurements as non-interceptive high frequency or low current monitoring. Close collaboration between CERN and industry allowed designing these new current transformers and achieving a performance level never reached before.

REFERENCES

- [1] J.H. Dieperink, J.-L. Bretin, E. Carlier, L. Ducimetière, G.H. Schröder, E.B. Vossenberg : "Design aspects related to the reliability of the LHC Beam Bump Kicker Systems", PAC 1997, Vancouver, B.C., Canada.
- [2] E.B. Vossenberg, L. Ducimetière, U. Jansson, J.H. Dieperink, J. Bonthond : "Dual Branch High Voltage Pulse Generator for the Beam Extraction of the Large Hadron Collider", Proc. 25th Int'l Power Modulator Symposium and High Voltage Workshop, 2002.
- [3] K. Unser: "Toroidal AC and DC current transformers for beam intensity measurements", Atomkernenergie Kerntechnik, Vol.47(1985)N°1.
- [4] Bergoz website: <http://www.bergoz.com/products/CT>.