

ELECTRON ACCELERATOR OF ELV-TYPE AND THEIR WORLDWIDE APPLICATION

Yu.I. Golubenko, N.K. Kuksanov, P.I. Nemytov, R.A. Salimov,
S.N. Fadeev, M.E. Veis, V.V. Prudnikov

Budker Institute of Nuclear Physics SB RAS Lavrentyev av. 11, Novosibirsk, 630090, Russia

Abstract

Beginning from 1971, the Budker Institute of Nuclear Physics Siberian Branch of Russian Academy of Science started its activity in the development and manufacturing of electron accelerators of the ELV-type for their use in the industrial and research radiation-technological installations. The ELV-type accelerators were designed with use of the unified systems and units enabling thus to adapt them to the specific requirements of the customer by the main parameters such as the energy range, beam power, length of extraction window, etc.. INP proposes a series of electron accelerators of the ELV-type covering the energy range from 0.3 to 2.5 MeV with a beam of accelerated electrons of up to 450 mA and maximum power of up to 400 kW. The design and schematic solutions provide the long term and round-the-clock operation of accelerators under the conditions of industrial production processes. The ELV accelerators are most popular accelerators not only in Russia, but in China, Korea, and etc.

INTRODUCTION

The main features of ELV-accelerators are as follows:

1. High power of electron beam in wide energy range, it means high productivity of EB processing;
2. High efficiency of conversation of electricity power to electron beam power. The efficiency is limited by frequency converter and in case of transistors frequency converter efficiency is increased up to 85-92%;
3. Simple procedure of accelerator control by operator due to control system based on IBM compatible computer. It allows operating accelerator in on-line mode.
4. Accelerator control system comprises a set of software and hardware covering all the accelerator units required an operative control and diagnostics.
5. Accelerator itself has simple design and high reliability. If some troubles appear our customers repair accelerator by themselves with our consulting by phone, as a rule.
6. After warranty service. It means we delivery spare parts or parts with limited lifetime or make any accelerator service after warranty period by separate contracts with the low price.
7. A set of additional equipment (such as transportation line, ring or double side irradiation system, 4-side irradiation system) increases the accelerator possibility.

8. ELV accelerators are stable in operation. The energy and beam current instabilities practically do not exceed +/-2%.

Basic parameters of the ELV-type accelerators are given below at the Table1. and ELV-4 is shown at Fig1.

Table1

	Energy range, MeV	Beam power, kW	Max. beam current, mA
ELV-0.5	0.4 - 0.7	25	50
ELV-1	0.4 - 0.8	25	50
ELV-2	0.8 - 1.5	20	25
ELV-3	0.5 - 0.7	50	100
ELV-4	1.0 - 1.5	50	50
ELV-6	0.8 - 1.2	100	100
ELV-8	1.0 - 2.5	90	50
ELV-6M	0.75 - 0.95	160	200
ELV-12	0.6 - 0.9	400	500

By now, over 100 accelerators had been delivered inside of Russia and abroad.

50 accelerators were delivered inside of former USSR

33 accelerators were delivered in China

12 were delivered in Korea

2 accelerators were delivered in Japan

2 accelerators were delivered in Poland

1 accelerators was delivered in Germany

1 accelerators was delivered in Chech Republic

1 accelerators was delivered in Bulgaria,

2 accelerators are delivering in India, and etc..

On international market we have strong competition with other firms producing accelerators. But number of delivered ELV accelerator during last 5 years is more than any others delivered accelerators. Many firms prefer to buy new ELV accelerator. So there are many plants where ELV accelerators are operating at same place and conditions with NHV and RDI accelerators.

Separate units and systems of ELV accelerators are widely used in installation for scientific research.

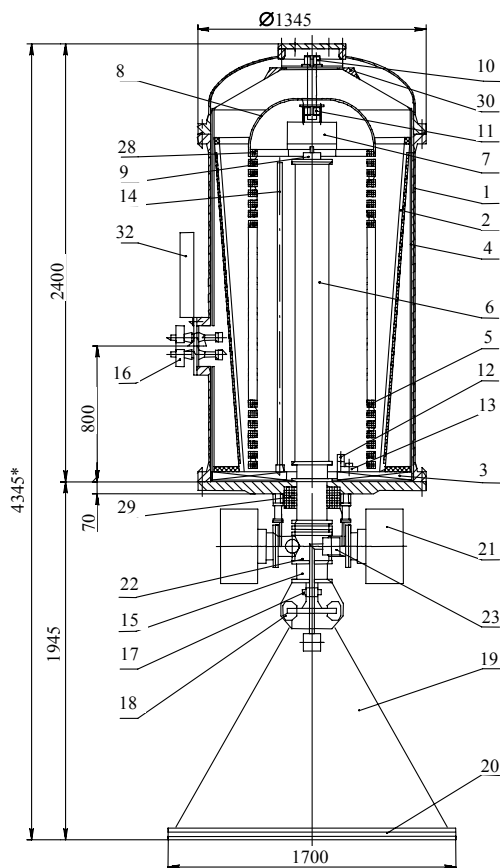

Figure 1 : General view of ELV-4 accelerator

1 - vessel, 2 - primary winding; 3,4 - magnitoguides; 5 - rectifier sections; 6 - accelerating tube; 7 - injector control unit; 8 - high voltage electrode; 9 - injector; 10,11 - optical channels for injector control; 12 - section divider; 13 - capacitor unit; 14 - energy divider; 15 - vacuum gate; 16 - primary winding terminals; 17,18 - scanning coils; 19 - extraction device; 20 - extraction window frame; 21 - vacuum pumps; 22 - cross head; 23 - vacuum gate; 28 - base of high voltage electrode; 29 - magnetic lens; 30 - high voltage shield; 32 - clamp set.

APPLICATION OF ELV ACCELERATORS

ELV accelerators are used practically in all technologies where electron beam is needed.

- 1 The main application of ELV-accelerators is modification of polyethylene insulation of cable and wires. The irradiation allows changing the properties of insulation: to make it thermo-, fire-, oil-, radiation- resists or with combined resistivity to these agents. The square of wire treated by ELV accelerator is from 0.1 to 120 mm². The productivity (depended on composition and properties) is up to 500 m/min.

We developed the system of 4-side irradiation for cable and pipes. This system increases the quality of

irradiation, because improves the azimuth homogeneity of absorbed dose. Simultaneously it decreases required energy for irradiation, i.e. increase efficiency of treatment. 4-side irradiation system is especially effective for treatment of big diameter cables.

- 2 Another profitable application of ELV accelerators is production of thermo shrinkable pipes, films and bands. The productivity can be up to 1000 kg per hour.

As a rule the accelerators for cable and thermo shrinkable irradiation operate round-o-clock (24 hours per day). About 85% of accelerators are treating polyethylene.

- 3 The production of artificial leather. It means the polymerization by EB the several compounds for manufacturing leather-like material with heat-, fire-, oil-, cool, and etc. resistance. Radiation-chemical technology allows obtaining both non-base material and coats on the substances of different type. This material is for shelters, overalls, shoes, and bags. Productivity is up to 1000 m.sq. per hour.

- 4 The production of self-adhesion bands and rubberizing items. It is also the polymerization by electron beam.

- 5 Composite material for soft roofing. Intended for making roofs of residential, public and industrial buildings and structures. It is a roll polymerfabric formed of rubber mix based on rubbers of general application with subsequent vulcanization by EB.

- 6 One accelerator is used for manufacturing of polyethylene-oxide gel.

- 7 One accelerator is used for production of pre-pregs based on carbon fiber fillers and polymer binders.

- 8 Curing lacquer-paint coatings on different bases for the building industry with productivity of up to 500-m.sq./per hour. 2 accelerators for this purpose are in Russia (but they are not operated now).

- 9 Desinsectization of grain with productivity 200T/hour per accelerator in Ukraine, 2 accelerators with productivity 500 T/hour in China.

- 10Waste water treatment. There was many lab scale installations using ELV accelerators for experiments. In 2005, in Taegu city (Republic of Korea) the full scale industrial installation for waste water treatment of dyeing textile center by an electron beam was put into operation. Installation productivity is up to 10000 cub. m/day. It is based on ELV-12 accelerator. The hall of irradiation treatment is shown on Fig.2

- 11Purification of flue gases of coal thermal station from Sulfur oxide and Nitrogen oxide.

For waste water and flue gas treatment we developed high power accelerator ELV-12. It's design adapted to environmental application.

- 12 ELV accelerators can be equipped by system for extraction to atmosphere the concentrated electron beam. It allows using accelerator for other kind of application such as: production of catalysts for the ammonia synthesis; evaporation of any materials for

producing super fine powders; surfacing and hardening of metals; welding, melting and cutting of metals, producing the special types of ceramics

13 Eight accelerators are installed in research and irradiation centers. Accelerator here is not connected with determined technology but is used as multifunction device. ELV accelerator is very convenient for this purpose due to wide range and high stability of beam parameters and irradiation fields, simplicity of control. Practically, researchers (chemists or others specialists) operate with

accelerator themselves without special training. Set of software allows obtaining required doze with high accuracy and repeatability.

Also in BINP we have special accelerator for investigation and developing of radiation processing. Our potential customer can make experiments with electron beam here. This accelerator has power up to 100 kW and beam energy 1.4 MeV.

In accordance with parameters and possibilities for users ELV accelerators are one of the best in the world.

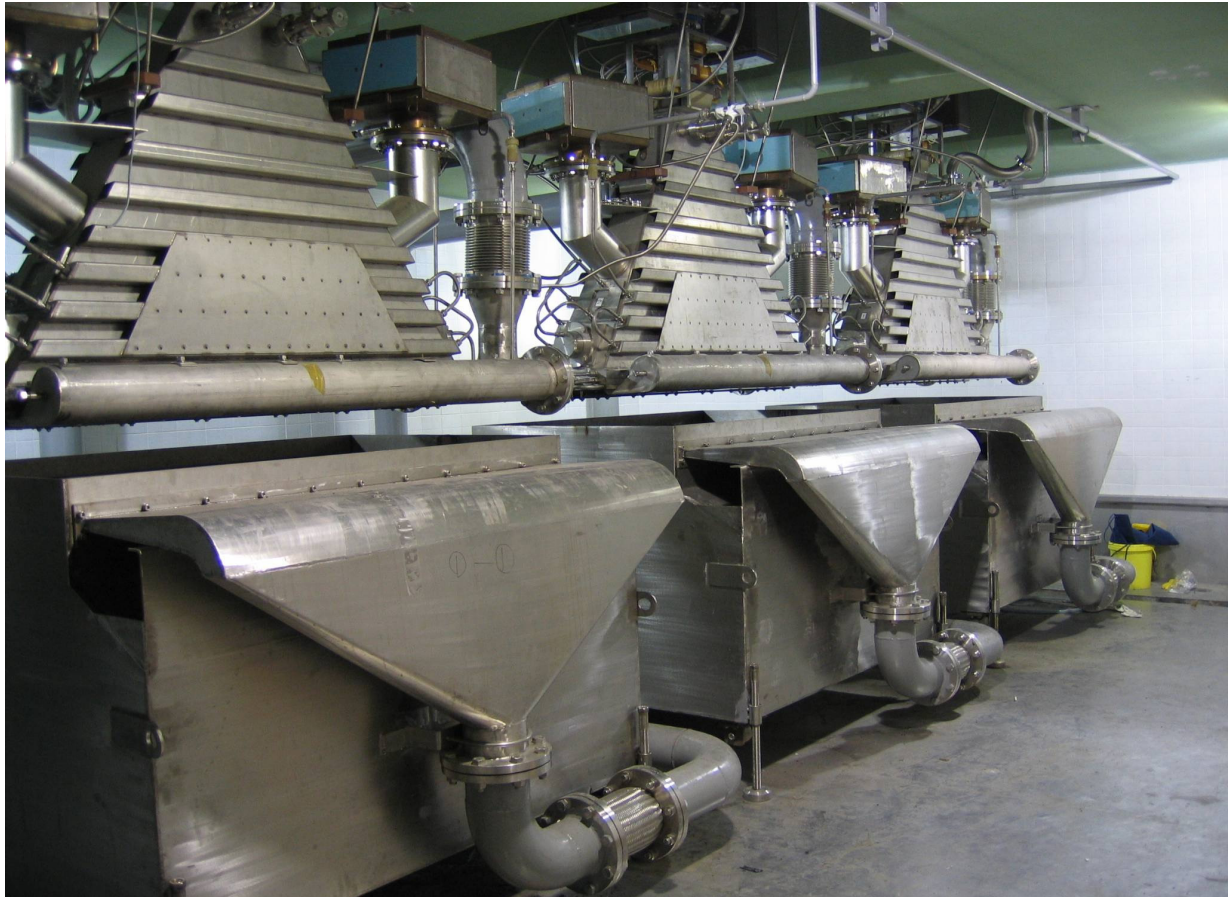

Figure 2 : The treatment of dyeing waste water by 400 kW electron beam. Taegu, Republic of Korea