

## NEW TIMING SYSTEM FOR THE L-BAND LINEAR ACCELERATOR AT OSAKA UNIVERSITY

Shigeru Kashiwagi\*, Goro Isoyama, Ryukou Kato, Shoji Suemine  
 ISIR, Osaka University, 8-1 Mihogaoka, Ibaraki, Osaka 567-0047, Japan  
 Takao Asaka, Yoshitaka Kawashima  
 SPring-8, 1-1-1, Kouto, Mikazuki, Sayo-gun, Hyogo 679-5198, Japan

### Abstract

A highly precise and flexible timing system has been developed for the L-band linac at ISIR, Osaka University. It provides four RF signals and several timing signals for operation of the linac and for experiments with the linac. In order to realize long-term stability of the timing system and hence operation of the linac, a rubidium atomic clock producing a 10 MHz RF signal with the fractional stability of  $10^{-15}$  is used as a time base for the synthesizer used as a master oscillator for generating the acceleration frequency of 1300 MHz. The 1300 MHz signal from the master oscillator is directly counted to produce the four RF signals and the clock signal of the timing system at 27 MHz. The master timing signals for linac operation is taken from the AC line frequency and it is precisely synchronized with the 27MHz clock signal. To make an arbitrary delayed timing signal, a standard digital delay generator is used to make a gate signal for a GaAs RF switch, with which one of the 27MHz clock pulses is sliced out to generate the delay timing signal. Any timing signal can be made in an interval of 37 ns and the timing jitter of the delayed signal is achieved to be as small as 2 ps (rms).

### INTRODUCTION

The L-band electron linear accelerator is used for studies on nanotechnology and beam science as well as for basic studies in the related fields at the Radiation Laboratory of the Institute of Scientific and Industrial Research (ISIR), Osaka University. The L-band linac can produce electron beams of different time structures, like a single-bunch, multi-bunch with 9.1 ns spacing and so on, corresponding to various beam experiments. The high intensity single-bunch beam is the most characteristic beam of this L-band linac and it is very useful for radiation chemistry studies by means of pulse radiolysis in the time range down to sub-picoseconds [1,2] and basic study of Self-Amplified Spontaneous Emission (SASE) in the far-infrared region [3,4].

The timing system of the linac plays a very important role in generating a high quality and stable electron beam. Timing jitter between a trigger signal for the electron gun and a reference RF signal of accelerator system directly affects the stability of the electron beam in terms of intensity and energy. Experiments using the L-band linac require synchronized trigger pulse for their data acquisition, and RF signals for laser oscillator. In order to

enhance the stability of the linac, we have developed a new highly precise and flexible timing system for the L-band linac at ISIR, Osaka University.

### CONFIGURATION OF L-BAND LINAC AND LASER SYSTEM

The fundamental accelerating frequency of the L-band linac at ISIR is 1300 MHz. The linac has been optimized for generating the high-intensity single-bunch beam. The L-band linac is consisted of a high-current triode electron gun, three stage sub-harmonic bunchers (two operate at 108 MHz, which is a 12<sup>th</sup> subharmonic of the fundamental frequency and one at 216 MHz, a 6<sup>th</sup> of 1.3GHz), two fundamental traversing wave bunchers and 3m-long main accelerating structure. The SHB system is used mainly for single-bunch operation. The timing system is required to generate three RF signals for these RF components.

Two grid pulser circuits of the electron gun are used for generating single-bunch and multi-bunch beam. The trigger pulse for the gun grid has to be synchronized with RF signals precisely. In single-bunch operation, one trigger pulse for the gun grid with 120V height and 50ns duration is distributed from the timing system. In multi-bunch operation, two triggers for a start and a stop of pulse are necessary to decide the pulse length of multi-bunch beam in the grid pulser circuit. The trigger pulse for single-bunch and the start trigger of multi-bunch generation are common, and the input trigger pulse for the trigger circuit of the gun is switched by operation mode of the linac.

The femtosecond laser system for picosecond pulse radiolysis experiment consists of a CW green laser, a femtosecond Ti:sapphire laser operated at 81 MHz, Nd:YLF laser with a regenerative amplifier operated at 960 Hz, an optical parametric amplifier (OPA) and pulse generator. Thus, the laser system requires 81 MHz RF signal and 960 Hz and 60Hz trigger pulses to the timing system of the linac.

### NEW SYNCHRONOUS TIMING SYSTEM

To achieve the stable and precise synchronization between RF signals and trigger pulses for the accelerator system, the timing system has been replaced with a new one. The new timing system of the linac comprises of a master RF part and a synchronous timing part. It provides four synchronous RF signals and a 27 MHz clock signal as well as various timing signals for operation of the linac and for the experiments. Fig. 1 shows a block diagram of new timing system for the L-band linac.

\*shigeruk@sanken.osaka-u.ac.jp

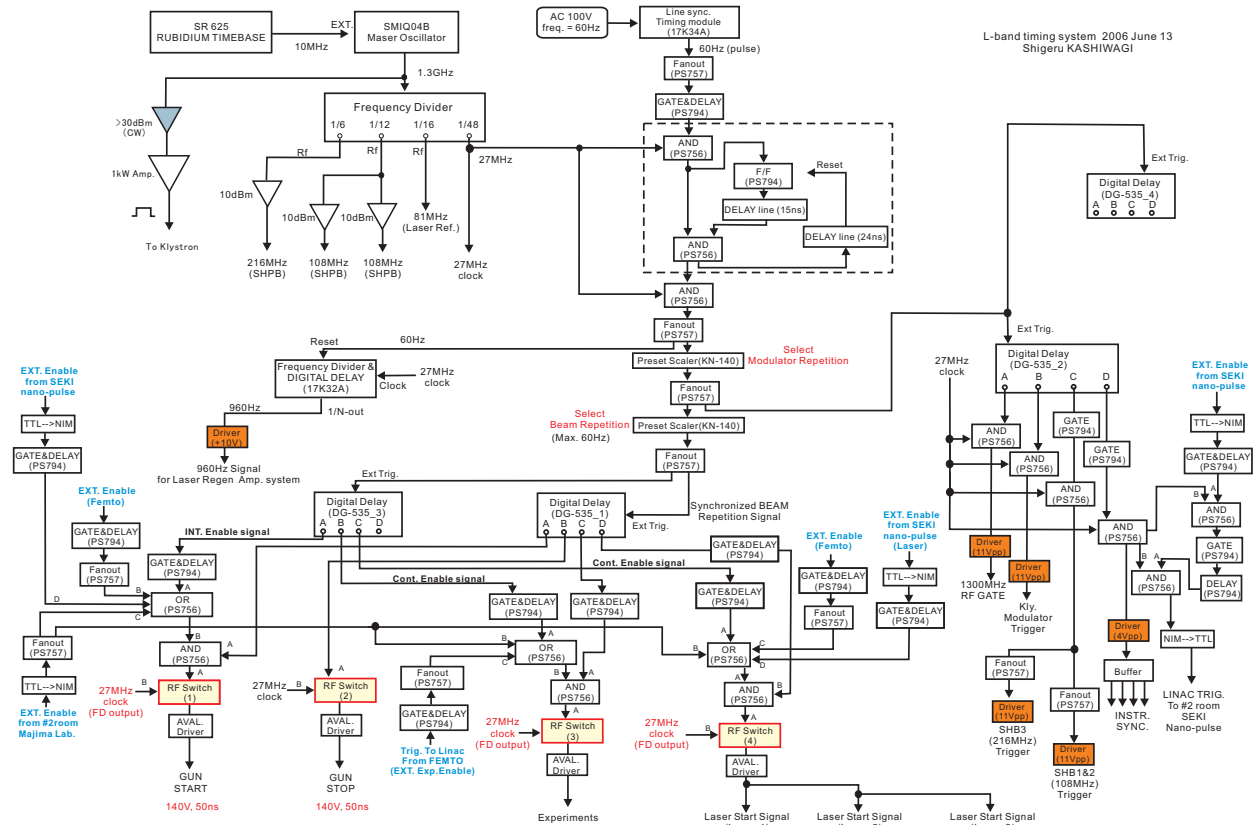

Figure 1: Block diagram of the new timing system for the L-band linac at ISIR, Osaka University.

**Master RF part**

In new timing system, some necessarily harmonic frequencies for the linac operation are produced by dividing a master frequency of 1300 MHz, because the phase fluctuation of the dividing frequency is much smaller than the multiplied one [5]. The master RF of 1300 MHz is generated by a frequency synthesizer (Rohde & Schwarz: SMIQ04B) and a rubidium atomic clock producing 10 MHz RF signal is used as an external time base for the frequency synthesizer to realize long term stability. The 1300 MHz RF signal is directly counted and frequency-divided using ripple counter circuit to produce RF signals of a 6th and 12th sub-harmonics at 108 MHz and 216 MHz, and a 16th sub-harmonic at 81 MHz together with the NIM-level clock signal of a 48th sub-harmonic signal at 27 MHz. Band-

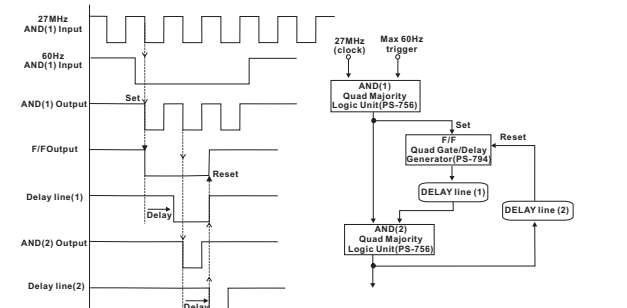

Figure 2: Timing chart and block diagram of synchronizing system using a logic circuit (Phillips-756) and flip-flop circuit (Phillips-794).

pass filters are introduced at the frequency divider output to suppress the higher and lower harmonic frequencies. These generated RF signals are distributed to each component or RF amplifier. The synchronized 27MHz clock pulses are used as timing step of trigger pulses.

**Synchronous timing part**

The synchronous timing part was fabricated using commercially available components and devices, such as standard NIM logic modules and digital delay generators, so that it is flexible for future expansion and development. The linac must be operated synchronously with the AC line frequency, which is 60 Hz in the western half of Japan, and the maximum repetition rate of the linac operation is also 60 Hz. In the synchronous timing part, the start signal is produced from the AC line voltage synchronized with the 27 MHz clock signal. Fig. 2 shows the timing chart and block diagram of synchronizing system using standard NIM modules and delay lines. The repetition rates of RF pulses and the beam are determined with two preset counter modules respectively. The 960 Hz clock is generated using synchronous universal counter, which counts the 27 MHz clock and divides the clock frequency [6].

To make an arbitrary delayed timing signal, the start signal is sent to standard digital delay generator (Stanford Research Systems: DG535) as the external trigger and it produces preset delayed signals. One of their delayed signals is used for producing a gate signal to slice out one of the 27 MHz clock pulses. Since the gun (start and stop),

the experimental and the laser triggers, have to be synchronized with the reference RF signal precisely, we therefore use a fast GaAs RF switch (Mini-Circuits: ZASWA-2-50-DR) to slice out the timing pulses from the 27MHz clock. The fast RF switch is a passive device, thus the time jitter of the sliced out timing pulse is determined by stability of the clock. This is expected to be shorter than a few ps. To make other trigger pulses, such as the klystron modulator trigger, the delayed signals are made to be coincident with the 27 MHz clock using a logic module. The time jitter of the logic module is expected to be about 5 ps. Thus, any timing signal can be generated at an integer multiple of 37 ns, which is a period of 27 MHz clock.

### Avalanche pulser

The avalanche pulser circuit is used to make high voltage pulse with less than a nanosecond rise time at the output part of the timing system. The timing jitter of the arbitrary delayed timing signal for triggering each component is mainly determined by a time jitter of the avalanche pulser. The required avalanche pulser outputs are 140 V and 50 V for the Gun-Start/Stop trigger and the Experimental/Laser triggers, respectively. The synchronized timing pulse is applied to the avalanche pulser circuit as a trigger. The time jitter of avalanche pulser is strongly dependent on the leading-edge of the drive pulse for the avalanche transistor. To get good leading-edge of the drive pulse, a transistor is used as a pre-amplifier with gain 5 and an emitter follower circuit is used for the last pre-amplifying stage to provide low output impedance. In this circuit, two transistors are used to provide the drive pulse with good leading-edge for

avalanche transistor. The timing jitter of this circuit was smaller than that of the circuit, which uses only one transistor in emitter ground circuit.

## TIMING JITTER MEASUREMENT AND RESULT

The timing jitter measurement have been performed for the produced subharmonic RF signals and the synchronous trigger pulses relative to the master reference RF of 1300 MHz using the Tektronix Communication Analyzer (Tektronix CSA8000B with 80E03 sampling module). In the measurement, the subharmonic RF signals or the timing pulses are used as a trigger of the oscilloscope. Absolute timing jitters of subharmonic frequencies relative to the master reference RF are approximately 1.3-1.5 ps (rms) and the jitter of 27 MHz clock was 0.96 ps (rms). To make the jitter smaller, we will use narrow band-pass crystal filter for subharmonic RF signals to suppress the phase noise.

A rise-time (10-90%) of amplified trigger pulse was also measured using the sampling module with 20 GHz frequency bandwidth. The measured leading-edge of the 50V trigger pulse with 46 dB attenuator is shown in Fig. 3 (upper) and the rise-time of the 140 and 50 V trigger pulses were 1.86 ns and 0.44 ns, respectively. Absolute timing jitter (rms) of trigger pulses relative to the master RF were 2.7 ps (pk-pk = 16.4 ps) and 1.5 ps (pk-pk = 10.0 ps) in 1 hour measurement, respectively.

## SUMMARY

The new highly precise and flexible timing system has been developed for the L-band linac and now it is used in real beam operation. Performance of new timing system improved than a former one. In the timing jitter measurement, the jitter of the 50 V trigger pulse relative to the master reference RF was 1.5 ps, before installation of new timing system it was about 5 ps. About other signals, the performance improved than before.

## REFERENCES

- [1] A. Saeki, T. Kozawa, S. Kashiwagi, K. Okamoto, G. Isoyama, Y. Yoshida and S. Tagawa, Nucl. Instr. and Meth. A 546 (2005) 627.
- [2] T. Kozawa, Y. Mizutani, K. Yokoyama, S. Okuda, S. Tagawa, Nucl. Instr. and Meth. A 429 (1999) 471.
- [3] R. Kato, M. Fujimoto, T. Igo, S. Isaka, T. Onishi, S. Furukawa, S. Okuda, S. Suemine, G. Isoyama, Nucl. Instr. and Meth. A 507 (2003) 409.
- [4] R. Kato, R. A. V. Kumar, T. Okita, S. Kondo, T. Igo, T. Konishi, S. Okuda, S. Suemine, G. Isoyama, Nucl. Instr. and Meth. A 445 (2000) 164.
- [5] M. Sawamura, E. J. Minehara, R. Nagai, M. Sugimoto, M. Takao, R. Kato, N. Kikuzawa, M. Ohkubo, Nucl. Instr. and Meth. A 358 (1995) ABS 73-74.
- [6] H. Suzuki, H. Ego, M. Hara, T. Hori, Y. Kawashima, Y. Ohashi, T. Ohshima, N. Tani, H. Yonehara, Nucl. Instr. and Meth. A 431 (1999) 249.

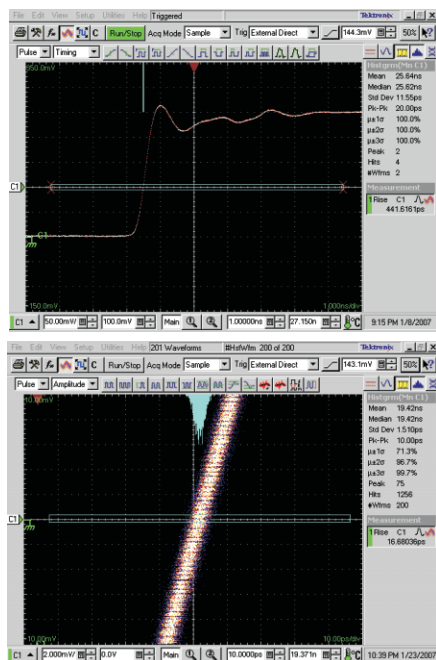

Figure 3: Measured leading-edge and timing jitter of 50 V trigger pulse. The rise time of one was 0.44 ns and the timing jitter was 1.51 ps (rms) and 10.0 ps (pk-pk) in 1 hour measurement.