

MAGNET DESIGN FOR THE MSU 50 MeV CYCLOTRON (\*)

H.G. Blosser

Michigan State University, East Lansing

Design Criteria

The magnet for the MSU cyclotron is of nominal 64" radius and will provide for fixed frequency acceleration of protons to energies up to 50 MeV and other ions to energies of corresponding magnetic rigidity. Details of the design were worked out in a series of model studies using a 1/6 scale model. The framework of initial assumptions which set guidelines for the design were :

- 1) The pole tip spiral should be small to provide maximum linearity in the orbit dynamics throughout the cyclotron and, particularly, to facilitate the design of a resonant extraction system.
- 2) For all particles the axial focusing frequency should be above 0.15 to provide a large axial phase acceptance and a high space charge limit, and below 0.30 to provide a comfortable working margin with respect to the  $\nu_r = 2\nu_z$  resonance. Both of these limits should apply in actual trimmed fields, i.e. ripple in  $\nu_z$  due to the relatively coarse spacing of the trimming coils should not take  $\nu_z$  out of the specified range.
- 3) The size of the magnet should be such that the desired energies could be obtained with peak fields in the hills of the magnet of no more than 18 kG, this stipulation being based in part on qualitative study of magnetization curves for iron and in part on a cost optimization study for the Berkeley 88" cyclotron<sup>1)</sup>.
- 4) The magnet gap should provide a clear space between the iron 6.75" high to allow for trimming coils, RF structure, and beam space.
- 5) In-so-far as was consistent with the previously cited factors, the design should minimize cost factors, particularly the load on the circular trimming coils.

Magnet Structure

Using the above guidelines, initial choices of yoke and coil size and pole tip diameter were made, based on results of magnet studies at Oak Ridge<sup>2,3)</sup>, and a program of model studies was initiated. The resulting final magnet structure is shown diagrammatically in Fig. 1. A photograph of the model magnet with upper half removed is shown in Fig. 2. The magnet core construction<sup>4)</sup> is scheduled for completion by May 1, 1963. The main parameters of the magnet are specified in Table I.

Field Data

Model studies of the cyclotron magnet were made using an apparatus which provided for automatic scanning of the field in rectangular coordinates (3600 point grid) and

---

(\*) Work supported in part by the National Science Foundation.

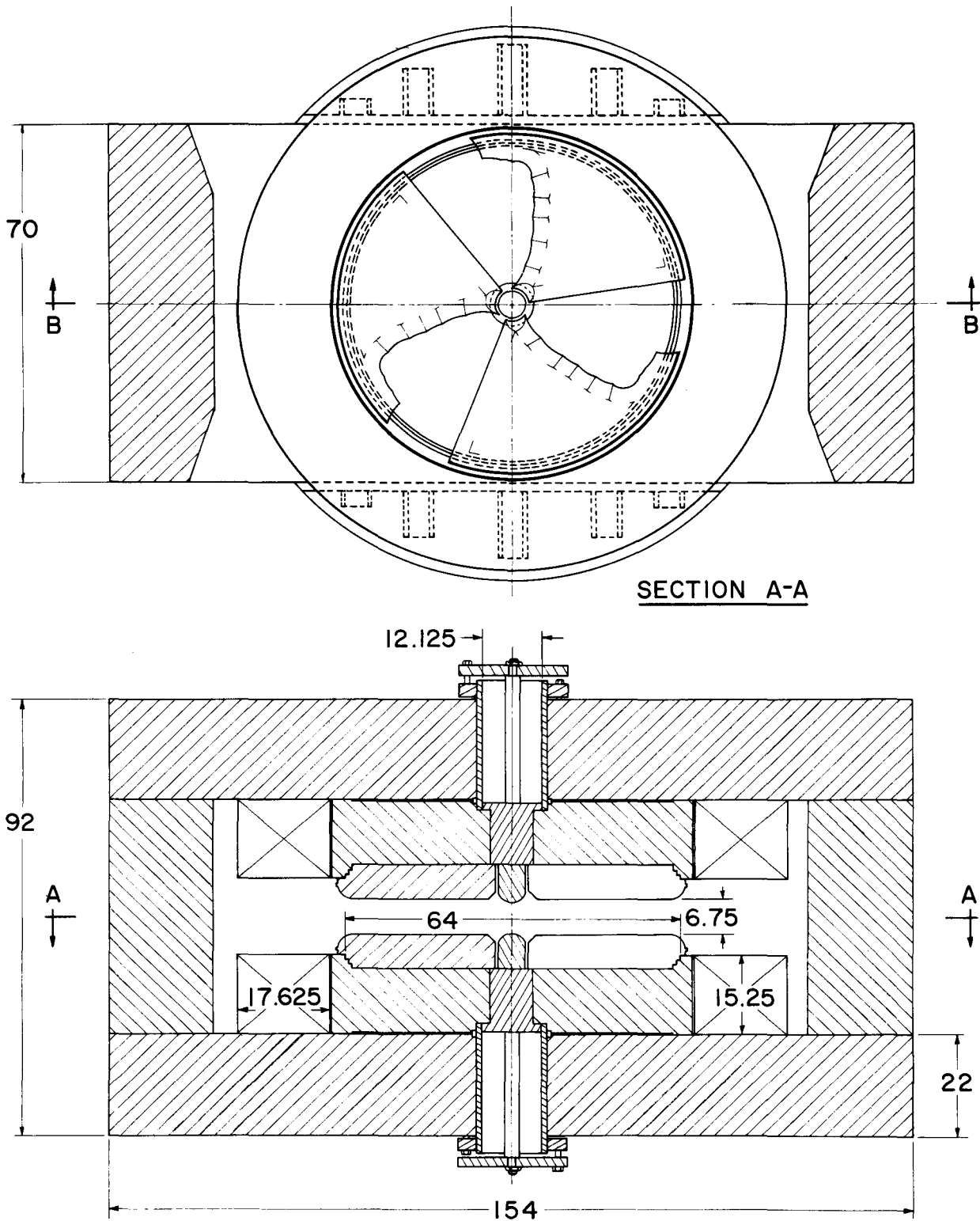

Fig. 1 Dimensional drawing of the magnet for the MSU cyclotron. The hole in top and bottom yokes is for possible ion source insertion. Dimensions are in inches.

recording of the data on punched cards. The overall accuracy of the system, as indicated by the amplitude of the first harmonic field component in the resulting data, was typically about 3 parts in 10,000 as compared with the average field. Data from the model facility are processed by a set of previously described computer routines<sup>5)</sup> to determine harmonic content and orbit properties.

Table I

Summary of Magnet Parameters for the MSU 64" Cyclotron

|                                      |                                 |
|--------------------------------------|---------------------------------|
| <u>Magnet Core :</u>                 |                                 |
| Weight                               | 103 tons                        |
| Cost (including shipment)            | \$ 61,584                       |
| Material                             | 1010 steel (cyclotron analysis) |
| Pole base cross sectional area       | 3737 in <sup>2</sup> , 100%     |
| Top and bottom yoke area             | 3080 in <sup>2</sup> , 82.4%    |
| Left and right side yoke area        | 2634 in <sup>2</sup> , 70.5%    |
| <u>Magnet Pole Tips :</u>            |                                 |
| Weight (set of six)                  | 3.78 tons                       |
| Cost (set of six, vendor's estimate) | \$ 25,000                       |
| Material                             | 1010 steel (cyclotron analysis) |
| <u>Magnet Coils :</u>                |                                 |
| Weight                               | 13 tons (both coils)            |
| Cost (including shipment)            | \$ 44,386.00                    |
| Material                             | copper (ETP grade)              |
| Number of turns                      | 320 turns/coil                  |
| Inner diameter                       | 69.75 in.                       |
| Outer diameter                       | 104.55 in.                      |
| Height (each coil)                   | 15.03 in.                       |
| Resistance 50°C (each coil)          | 0.140 ohm max.                  |
| Power (425,000 ampere-turns, 50°C)   | 123.5 kW                        |

The general form of the magnetic field is seen in Fig. 3 which is a contour map drawn directly from measured data taken at an excitation of 415,000 ampere-turns<sup>6)</sup>. The azimuthal average of this field is given by the upper curve in Fig. 4 and the amplitude and phase of the main harmonics are given in Fig. 5. The field has a central "cone" similar to that studied by Stover<sup>7)</sup> as is clear from the figures. This cone is produced by a separate small central plug in the pole tip which can be seen in Fig. 2. The desirability of such a field cone is still under evaluation; if desired, the cone can easily be removed by a slight modification of the small central plug, as has been verified in other model studies.

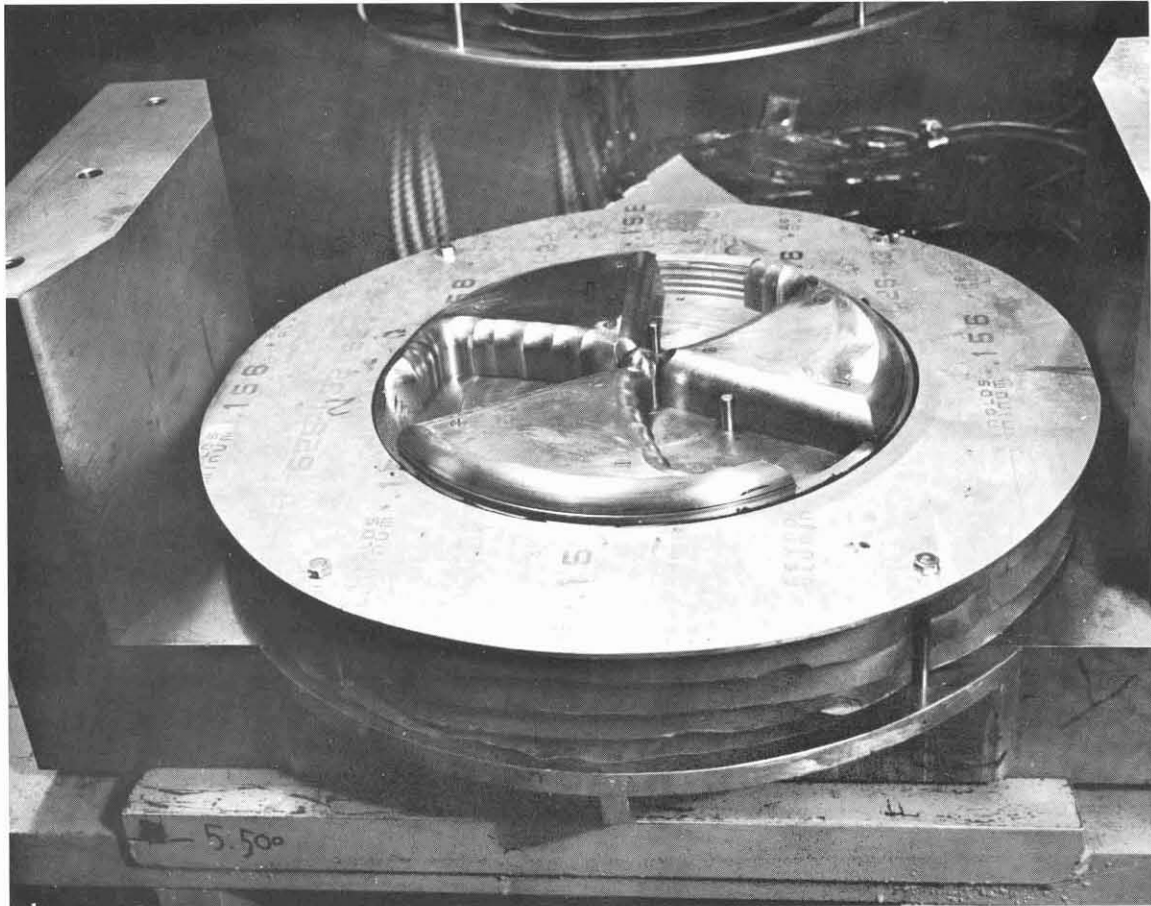

Fig. 2 Photograph of 1/6 scale model magnet with upper half removed to show pole tip structure.

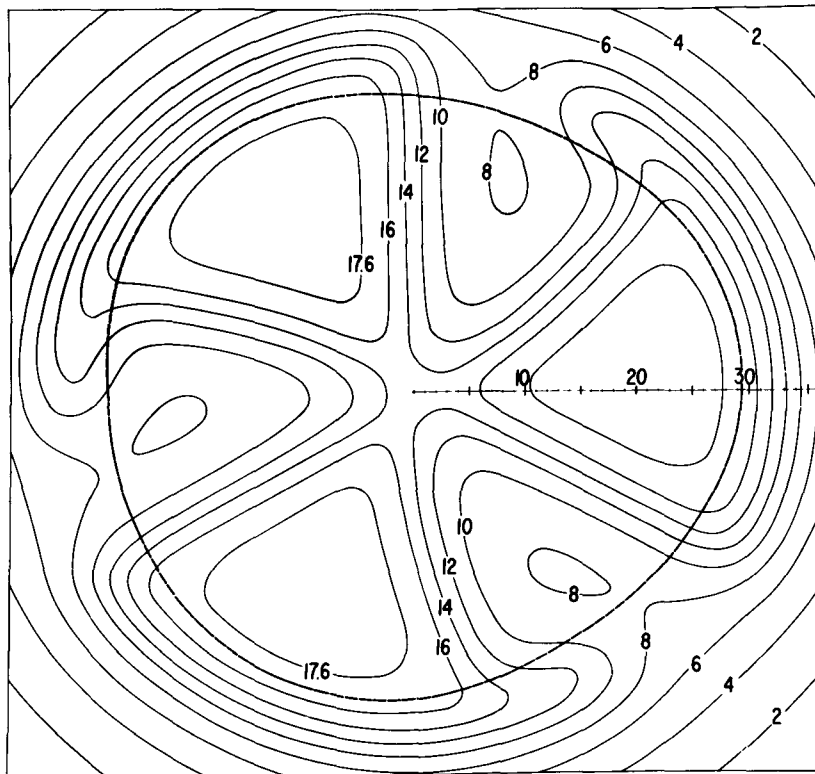

Fig. 3 Contour map of the magnetic field at an excitation of 415,000 ampere-turns. The heavy dashed line is the equilibrium orbit for a 49 MeV proton in the measured field.

Referring again to Fig. 1 and 2 it will be noted that all protruding corners of the pole tips are rounded. This greatly reduces saturation effects arising from the bunching of field lines at the corners of the iron; the iron surface becomes an approximate equipotential at both low and high fields<sup>8)</sup>. The effect of this rounding can be seen in Fig. 4 which gives the azimuthal average of the field at four different excitations spanning the full operating range of the magnet<sup>9)</sup>. The radial position of the outer field maximum, the crucial factor in the determination of the extraction radius, varies by only 0.5"; this invariability of the field shape markedly simplifies the design of the extractor.

#### Trial Trim Coil Fits and Orbit Properties

To obtain an initial estimate of required trimming currents, fits have been calculated assuming a layer of eight air-cored coils<sup>10)</sup> positioned 3.06" above and below the medium plane, corresponding to the planned position of the actual trimming coils in the full scale magnet. The use of air core coils for the trimming calculation should overestimate the ampere-turn requirement by a factor of perhaps 1.6 and should also accentuate the effects of ripple due to the coarse spacing of the coils<sup>11)</sup>.

Fig. 6 shows the currents, calculated by least squares fitting, required to trim the peak field of Fig. 4 for protons and the next highest field from Fig. 4 for

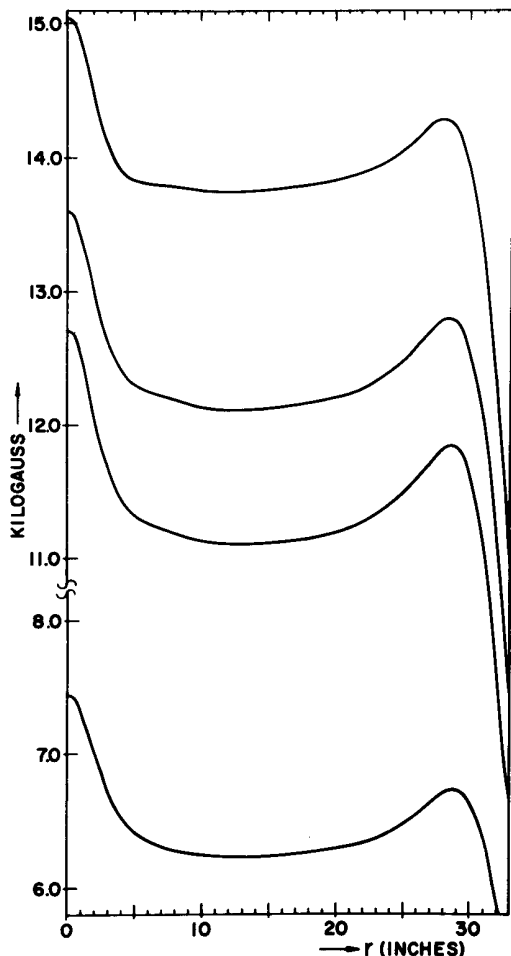

Fig. 4 Azimuthal average of the magnetic field at excitations of 415,000, 312,000, 264,000, and 120,000 ampere-turns.

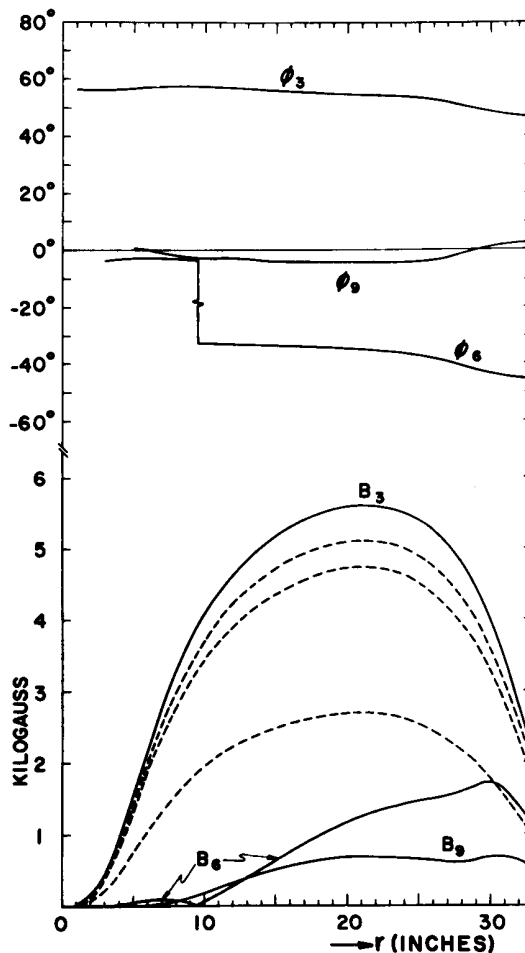

Fig. 5 Solid curves - phase and amplitude of major magnetic field harmonics at excitation of 415,000 ampere-turns. Dashed curves - amplitude of third harmonic at excitations of 312,000, 264,000, and 120,000 ampere-turns.

$C^{4+}$  ions, these two representing, respectively, the maximum buck and boost requirement on the coils. The figure also shows the power dissipated in each coil assuming the coils to be constructed from a double layer of 1/4" square hollow copper approximately covering the available area on each pole. Fig. 7 and 8 show the fitted fields in the two cases along with isochronous fields and measured fields. In the proton case a deliberate non-isochronism is introduced at large radii to augment the axial focusing. This acts to reduce the difference between proton and heavy ion  $\nu_z$  values, hence having much the same effect as a valley or flutter coil. At the same time the non-isochronism is so small that the total number of turns is increased by only 0.4% as compared with a completely isochronous field.

Fig. 9 and 10 present equilibrium orbit data for the two fitted fields. Shown are the radial and axial focusing frequencies,  $\nu_r$  and  $\nu_z$ , the fractional frequency error,  $\Delta\omega/\omega = \omega_{RF}/\omega - 1$ , and the phase for a particle leaving the central cone at the peak energy gain phase<sup>1,2)</sup> and accelerated in the proton case with a sinusoidal voltage of 280 kV/turn, and in the case of  $C^{4+}$ , on the third mode of a sinusoidal

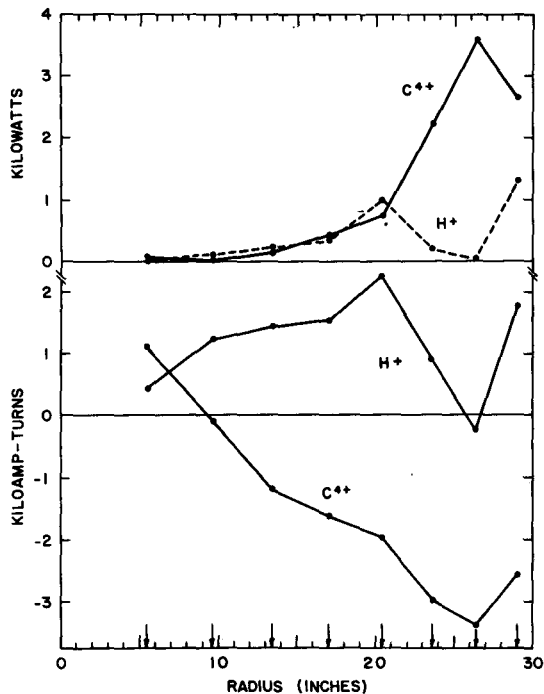

Fig. 6 Computed trim coil currents and power assuming air core coils located 3.06" from median plane at radii shown by the arrows. Currents and powers are totals for both coils of each pair. The points are plotted at the radial location of the coil - the lines connecting the points are of no significance.

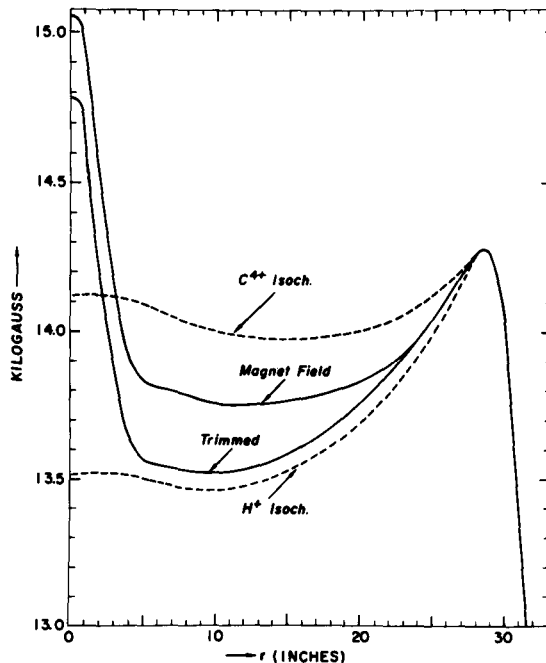

Fig. 7 The measured magnet field at 415,000 ampere-turns, the computed isochronous fields for protons and  $C^{4+}$  ions, and the proton trimmed field (obtained by adding to the measured field the field of aircored trimming coils with currents as per Fig. 6).

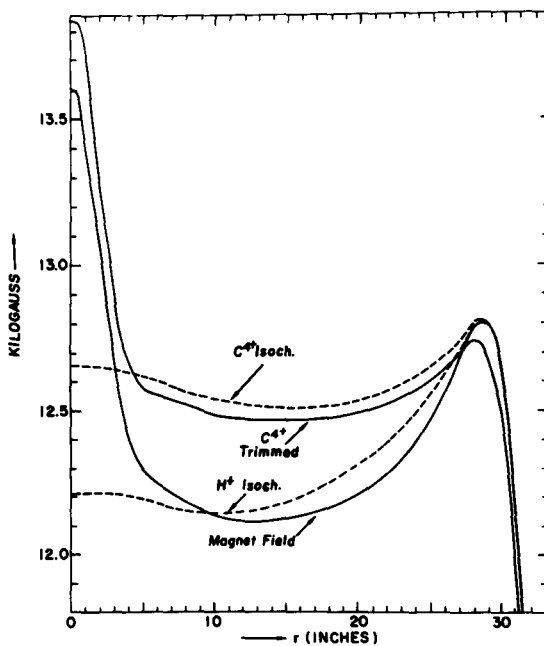

Fig. 8 The measured magnet field at 312,000 ampere-turns, the computed isochronous fields for protons and  $C^{4+}$  ions, and the  $C^{4+}$  trimmed field.

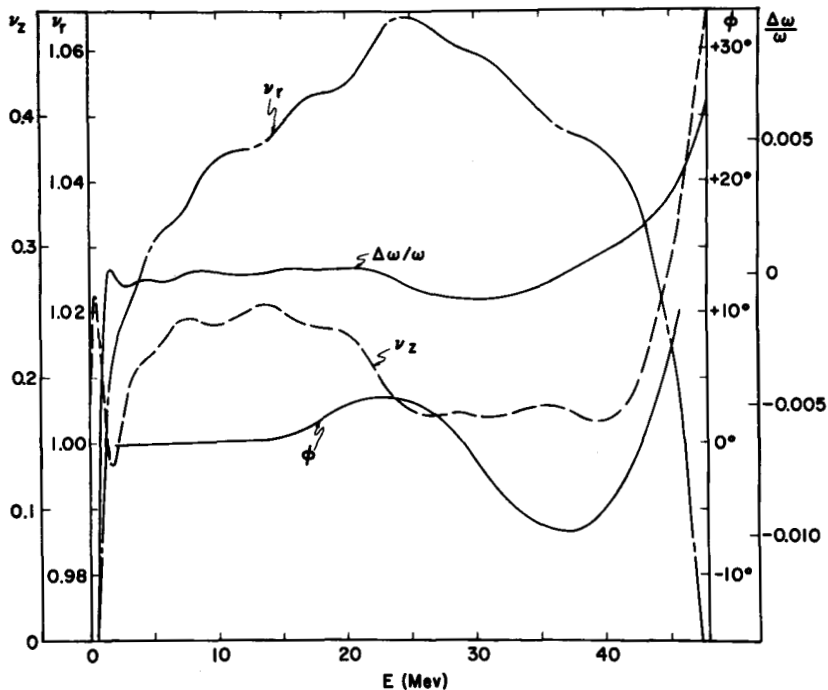

Fig. 9 Equilibrium orbit data for the trimmed field from Fig. 7.  $\nu_r$  and  $\nu_z$  are the radial and axial focusing frequencies in units of the orbital frequency,  $\Delta\omega/\omega$  is the fractional frequency error, and  $\phi$  is the phase for a proton accelerated with 280 kV/turn.

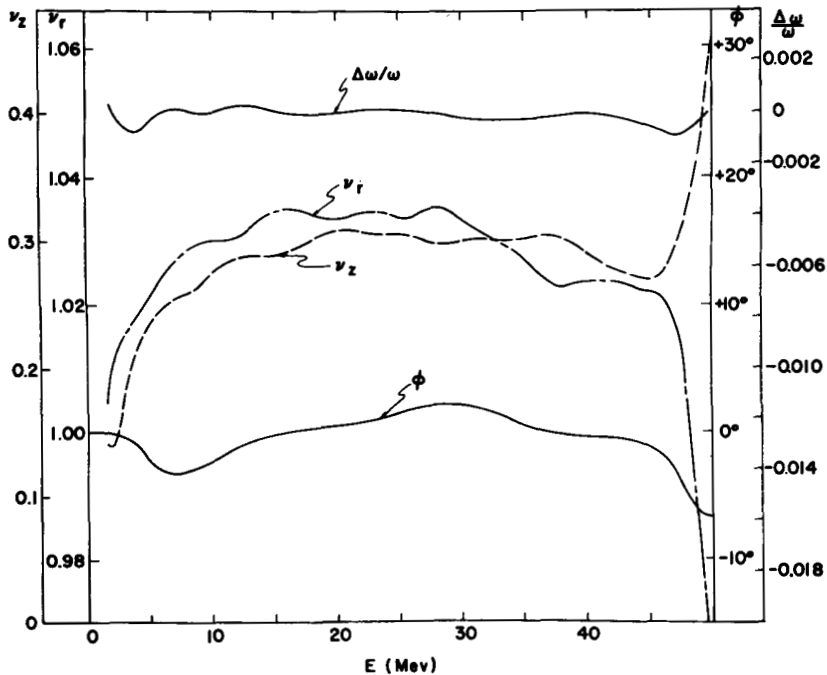

Fig. 10 Equilibrium orbit data for the trimmed field from Fig. 8. The phase curve is for a  $C^{4+}$  ion accelerated with 70 kV/turn. The extreme low energy portion of the curves has been omitted - the behaviour in this region closely resembles Fig. 9.



- 277 -

voltage of 70 kV/turn. The axial focusing frequency is seen to satisfy in both cases the design objectives of the first section. Other orbit properties are similarly well behaved.

### Conclusions

The results establish that low-spiral high-flutter magnets can be constructed within reasonable cost and power limitations. The total cost for the magnet core, coils, pole tips, and main power supply is approximately \$ 164,000. This cost represents approximately 1/6 of the total cost of the cyclotron which is a reasonable fraction of project costs to invest in the magnet. Although data for direct cost comparison with high spiral magnets is not available, the reasonable fractional costs relative to the remainder of the cyclotron refute an often quoted contention that high spiral is an economic necessity.

The preliminary trim coil calculations indicate very moderate requirements; it is planned to provide each trim coil pair with a 30 V, 250 A commercially available power supply yielding a connected capacity of 60 kW. Considerably less than half of this connected power will be in use at any one time so that consumed power will be in the 20 to 30 kW range. The rounded pole tip corners are believed to be a main factor in minimizing the trimming requirements. The results also establish the feasibility of achieving large  $v_z$  values near the center by the use of a magnetic cone.

At the time of writing (April 1, 1963) the magnet core, coils and power supply are all in an advanced state of construction with delivery scheduled for May and June, 1963. Full scale magnet measurements should begin during the coming summer.

### References

1. R. Burleigh, LRL Engineering Note UCID-11, 4601-81 M2, Feb. 20, 1958 (unpublished).
2. H.G. Blosser et al., Bull. APS 3, 233 (1958).
3. The initial choice of magnet size was actually based on 40 MeV protons. Subsequent studies established that energies of up to 50 MeV could be obtained with a magnet of the size selected.
4. The magnet core is being constructed by the Allis-Chalmers Manufacturing Co., Milwaukee, Wisconsin.
5. T.L. Arnette et al., Nucl. Instr. and Meth. 18-19, 343 (1962).
6. To minimize confusion, all quantities regarding the model measurements are given as equivalent full scale values.
7. J.E. Stover, Michigan State Univ. Cyclotron Project Report, MSUCP-3 (1960).
8. The author is indebted to Tat K. Khoe for suggesting this arrangement and for several discussions.
9. A factor of two in field strength is adequate for all particles, since one can change the charge state of the ion to obtain lower energies.
10. Due to the difficulty of modeling trim coils, actual measurements of trim coil fields will be made only in the full scale magnet. In the absence of better data the air-core assumption is invoked.
11. C. Dols (private communication).
12. It is assumed the phase slip introduced by the field cone is compensated by a lengthening of the first half turn. The lengthening required has the added desirable effect of introducing strong electric focusing on the early turns.

DISCUSSION

BERKES : Do you have any idea how far it would be possible to go with  $\nu_z$ ? Would it be reasonable to assume a  $\nu_z$  between 0.4 and 0.45?

BLOSSER : I feel sure it would be reasonable over all of the acceleration process except near extraction, where  $2\nu_z \approx \nu_{\pi}$  is always causing a difficulty. Of course it is near extraction where  $\nu_z$  is rapidly rising.

VERSTER : Can you define sufficiently well the shape of the segments with rounded edges?

BLOSSER : We have an inspection system worked out by Brobeck and our contract calls for the poles to be produced alike to  $\pm 0.003$  in.