

CYCLOTRON BEAM POSITION SENSOR

K. Johnson and W.J. Ramler
Argonne National Laboratory
(Presented by W.J. Ramler)

With the many advancements and experimental techniques available to experimentalists working with cyclotrons, a suitable method of monitoring to establish the spatial position of the beam remains a problem. A non-intercepting beam position sensor has been developed and used with the external focused beam of the Argonne cyclotron. It consists of resonantly tuned detection coils, preamplifier and receiver. Using magnetic induction techniques a d.c. beam current of $0.03 \mu\text{A}$ can be centrally located to about $\pm 0.1 \text{ mm}$ with positioning accuracy decreasing for lower beam currents. The sensor can establish the time average position of the beam but will not provide information in regard to fine structure, i.e., location of each projectile pulse.

The possibility of such a device for use with an external cyclotron beam was mentioned in an earlier publication by the authors¹⁾ in connection with a beam position sensor for an electron linear accelerator. The detection problems for the two accelerators are quite different. The cyclotron produces peak current pulses of microamperes in magnitude and megacycles/sec in repetition rate as compared to milliamperes and cycles/sec for the electron linear accelerator.

The paper that follows will discuss the unit that has been used with the external ANL cyclotron beam for a d.c. current range of about 0.01 to several microamperes.

Theory

Two sets of detection coils are required to determine the horizontal and vertical coordinates of the beam position. Each coil set consists of two coils, connected in opposition and symmetrically placed about the mechanical center of the beam tube. The axis of the coils are located perpendicular to the direction of the beam and the direction to be sensed.

For analysis, consider the beam $i(t)$ to be a filament of current; then the voltage induced per coil is given by

$$e = \frac{K}{r} \frac{\partial i}{\partial t} ,$$

where r is the effective distance from the current filament to the coil axis, t is the time and K is a constant. If the current filament is symmetrically positioned between the two coils, the voltage output will be zero. If it is displaced a distance Δr towards one of the coils, the output voltage is

$$e_1 = K \frac{\partial i}{\partial t} \left[\frac{1}{r_A} - \frac{1}{r_{A'}} \right],$$

where $r_A = r + \Delta r$ and $r_{A'} = r - \Delta r$. Neglecting second order terms in Δr and considering only the time derivative of the current, the voltage will be

$$e_1 = \pm K_0 \frac{di}{dt} \Delta r, \quad (1)$$

where $K_0 = -4\mu AN/r^2$; μ is the effective permeability of the coil-filament flux loop, A the effective cross-sectional area of the coil, N the total turns of a coil and r the distance from the current filament i to the axis of the coil. Signal polarity (\pm) will depend on the direction of displacement. The magnitude and polarity of e_1 may be used to determine the beam position.

For the purpose of analysis, it will be assumed that the external cyclotron beam current can be represented by a periodic series of triangular pulses of magnitude I_0 , duration τ and period T_0 . The Fourier series for such a current is

$$i = I_0 \left[\frac{\tau}{2T_0} + \sum_{n=1}^{\infty} A_n \cos n\omega t \right].$$

The voltage induced in the sensor circuit is by Eq. (1)

$$e_1 = \pm K_0 I_0 \Delta r \omega \sum_{n=1}^{\infty} n A_n \sin(n\omega t).$$

To utilize the voltage e_1 , the sensor input circuit is tuned to the $n = 1$ mode (Fig. 1). The voltage developed across the capacitor C_{EQ} is

$$e_2 = \pm Q K_0 I_0 \Delta r \omega A_1 \sin(\omega t), \quad (2)$$

where Q is the quality factor of the circuit. This voltage is amplified and used to indicate beam position.

If both the displacement Δr and beam amplitude I_0 are small, the voltage e_1

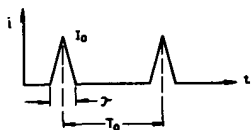
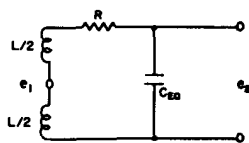

Fig. 1 Equivalent electrical circuit of the sensor and assumed accelerator beam pulse shape. $L = 31.4 \mu\text{H}$; $R = 26 \Omega$; $C_{eq} \approx 6.4 \text{ pF}$; $C = C_1 + C_2 + C_3$, where $C_1 =$ effective coil capacitance $\approx 3 \text{ pF}$, $C_2 =$ tuning capacitor $\approx 0.7 \text{ pF}$, and $C_3 =$ input capacitance at amplifier $\approx 2.7 \text{ pF}$.

will be small and the thermal noise e_n of the sensor circuit must then be considered. Assuming that all other noise generators in the amplifier-detector system are negligible then the equivalent driving voltage of the sensor will be e_1 in the series with e_n . This noise voltage is a limiting

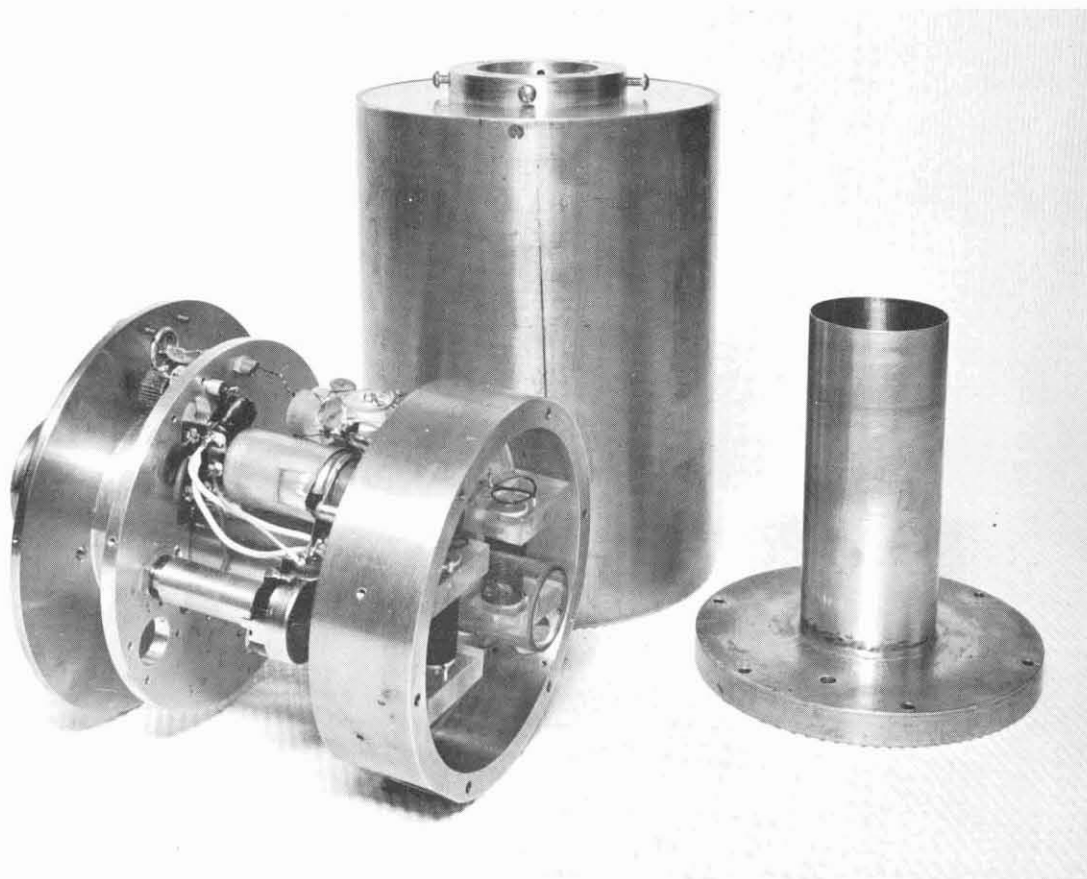

Fig. 2 Components of the sensor.

factor in the beam detection. Its effects are minimized by providing a sharply-tuned amplifying system.

Equipment Description

The sensor consists of the detection circuit and preamplifier. The receiver consists of the amplifier and detector. The sensor and associated electronics were constructed with simplicity to prove the feasibility of the technique and to obtain operating experience. Although the sensor housing described below is capable of accommodating two sets of detection coils, only one set was installed and was positioned to determine horizontal beam displacements.

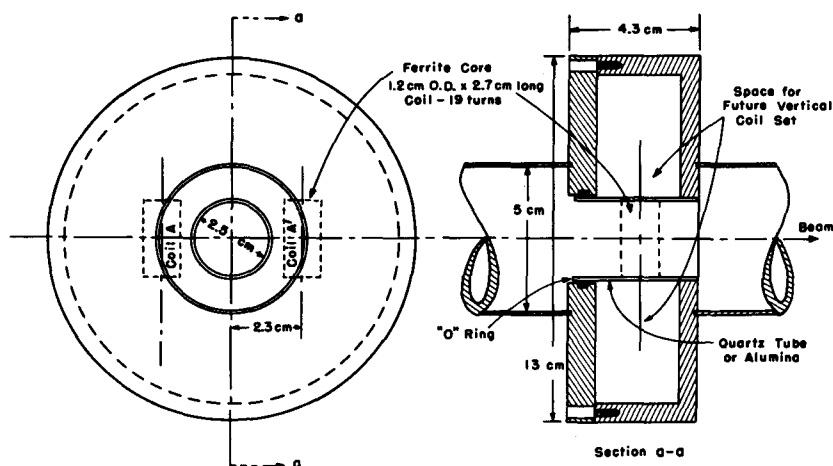

Fig. 3 Mechanical layout of the sensor.

Referring to Fig. 2 and 3, it is seen that the coils, A and A', are mounted within a brass housing but located externally to the vacuum system. The evacuated beam tube is of quartz to permit flux linkage between the beam and the coils. The outer surface of the shell connects mechanically and electrically to the beam tube of the accelerator.

Each sensor coil consists of 19 turns of No. 20 solid copper conductor wound on a Type Q-1²) ferrite core, 1.2 cm outer diameter, 2.7 cm long. The circuit is tuned to the cyclotron's fundamental frequency of 11.2 Mc/s and has an effective Q of 85. The effective 26Ω series resistance of the sensor circuit is the input thermal noise generator.

The two coils, A and A', are connected in opposition with the output leads short-coupled to the preamplifier which isolates the resonance sensor circuit from the coaxial cable connection used to bring the signal to the amplifier readout station. The preamplifier, of voltage gain about one, is constructed inside the sensor housing and is well shielded to minimize stray RF coupling. It uses Amperex E 180 F pentodes and has an equivalent noise resistance about 150-fold less than the sensor circuit.

The output from the preamplifier is led by a 100 ft coaxial cable, Type RG22B, to an RF amplifier. The purpose of this amplifier is twofold; it must first provide high selectivity to minimize the thermal noise effects, and second to provide sufficient signal gain for readout. A commercial type communication receiver was first used, but stray pickup effects were occasionally experienced. For subsequent work an amplifier was constructed with specific attention being given to shielding in the earlier stages of amplification. Briefly, the input signal (11.2 Mc/s) from the pre-amplifier is amplified and then heterodyned with a fixed 6.7 Mc/s oscillator giving a 4.5 Mc/s signal. The resultant 4.5 Mc/s signal is then amplified and mixed with a fixed 4.020 Mc/s signal, thereby producing a 480 kc/s output. It is by this means of heterodyning and the use of tuned circuits that an effective bandwidth of ± 2 kc/s is obtained. Since the noise output is directly proportional to the square root of the bandwidth, the bandwidth of the amplifier is a determining factor in establishing the best beam-displacement detection.

For signal readout, the amplifier is coupled into a linear detector, with the d.c. output used to indicate beam position. However, the direction of beam displacement is hereby lost. This has not been a serious disadvantage, since we are primarily interested in having the beam charge center coinciding with the mechanical center of the targetry. Direction of beam displacement is sensed with a steering magnet and then manually corrected. For automatic control, the amplifier readout system must become more sophisticated. Bench tests are now underway for phase detection and will be briefly discussed at the end of this paper.

Operation Results

Typical beam displacement data are given by the curves of Fig. 4 and 5. The data were obtained with an amplifier voltage gain of 0.9×10^6 and an output noise

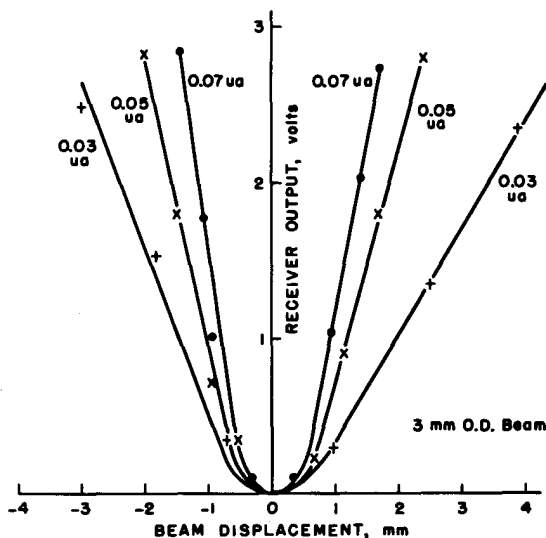

Fig. 4 Measured sensor-amplifier signal versus beam displacement. Sensitivity is about $45 \mu\text{V}/\text{mm} \mu\text{A}$. Beam diameter 3 mm.

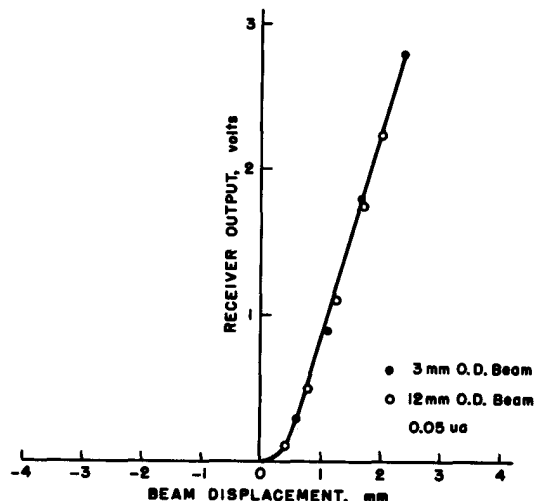

Fig. 5 Measured sensor-amplifier displacement signal for a 3 mm and a 12 mm diameter beam.

- 315 -

signal of 2.7 V. Operating experience has proven that a d.c. beam current of 0.03 μA can be centrally located to about ± 0.1 mm with positioning accuracy decreasing for lower beam currents.

It is to be noted that the d.c. output beam displacement signal is not linear as predicted by equation (1). This is the result of linearly detecting two signals of comparable magnitude; beam displacement and noise. When the output displacement signal greatly exceeds the noise, the resultant d.c. detector signal will be directly proportional to e_1 , which is illustrated by the curve for 0.07 μA .

The measured and calculated sensitivity of the sensor (preamplifier input) is about 45 $\mu\text{V}/\text{mm}\mu\text{A}$ and 40 $\mu\text{V}/\text{mm}\mu\text{A}$ respectively. The output thermal noise signal (± 2 ke/s bandwidth) referred back to the preamplifier input is about 3 μV .

Discussion

If the null detection readout does not suffice, direction of beam displacement can be sensed by providing a means of time referencing the sensor signal to the projectile pulse. This has been readily accomplished on the bench by using two signal channels, A and B, with channel A deriving its input signal from an air core toroid (current transformer) mechanically coupled with the sensor head and tuned to the first harmonic frequency of the projectile pulse. The input signal for channel B is developed by the described sensor circuit. Since both channels have the same phase characteristics, beam displacement display is accomplished by coupling the sensor signal output of channel B, to an oscilloscope with the time triggering pulse being provided by the toroid signal, channel A. The \pm characteristic of the first swing of the sensor signal provides the information as to the direction of beam displacement.

The electronics of either channel consists of a preamplifier with its output signal led by a coaxial cable to a mixer (11.2 Mc/s - 6.7 Mc/s) which produces a 4.5 Mc/s information signal. This signal is amplified and then directly coupled into the oscilloscope.

To achieve variable frequency, i.e. variable energy operation, the sensor circuit must be constructed for tuning to the highest accelerating frequency. The question now arises as to the feasibility of modifying the described circuit to resonate at a higher frequency, such as 20 Mc/s. Since the capacitance cannot readily be decreased, one must consider decreasing the inductance of the sensor coils by lowering the number of turns. This will result in a proportional decrease in sensitivity and will also lower the signal to noise ratio. If a_0 and a_1 are the signal-to-noise ratios and N_0 and N_1 are the coil turns for the frequencies f_0 and f_1 , then $a_1 = a_0 (N_1/N_0)^{3/4} = a_0 (f_0/f_1)^{3/4}$. To change from 11.2 Mc/s to 20 Mc/s operation, the coil turns must be decreased by a factor about 1.8, and the resulting change in the signal-to-noise ratio will be a factor of about 1.5. This is not serious and can be readily overcome by narrowing the band width of the amplifier.

- 316 -

For frequencies less than the design maximum we propose to use a tuning capacitor. This will lower the Q of the circuit and for constant gain the decrease would have to be compensated by the amplifier. To follow the change in accelerating frequencies, the sensor circuit, preamplifier, amplifier preceding first mixer, and the amplifier of the cyclotron heterodyning signal would have to be gang-tuned. The remainder of the electronics would remain unchanged.

References

1. K. Johnson, et al., Nucl. Instr. and Meth. 14, No. 2 (1962).
2. Indiana General Corporation, Valparaiso, Indiana.

DISCUSSION

SMITH : What type of ferrite are you using?

RAMLER : Type Q1. It has a permeability of about 400 at our frequency. The permeability of the flux loop, relative to air, is about 3.3.