

SUPERCONDUCTING CONVERSION OF THE OAK RIDGE ISOCHRONOUS CYCLOTRON

J.A. Martin, J.B. Ball, T.P. Cleary,[†] E.D. Hudson, R.S. Lord, C.A. Ludemann, S.W. Mosko, T.A. Welton,
J.K. Ballou,^{*} R.L. Brown,^{*} W.H. Gray,^{*} S.W. Schwenterly,^{*} G.S. McNeilly,^{**} and P.S. Litherland.^{††}

Physics Division, Oak Ridge National Laboratory,[†] Oak Ridge, Tennessee 37830, U.S.A.

[†]World Information and Technology Systems Corp., 235 Yorkland Blvd., Willowdale, Ontario M2J 4W9, Canada.

^{*}Fusion Energy Division, Oak Ridge National Laboratory, Oak Ridge, Tennessee 37830, U.S.A.

^{**}Computer Sciences Division, Union Carbide Corporation-Nuclear Division, Oak Ridge, Tennessee 37830, U.S.A.

^{††}Engineering Division, Union Carbide Corporation-Nuclear Division, Oak Ridge, Tennessee 37830, U.S.A.

Abstract.— The superconducting conversion of ORIC is being planned to replace the aluminum main magnet coils with a NbTi superconducting coil system. The average magnetic field would be increased from the present 1.9 T to 3.3 T to provide a maximum increase in energy from 100 to 300 q^2/A^2 .

1. Introduction.— The Oak Ridge Isochronous Cyclotron began operation in 1964. In early years, the cyclotron was used primarily for light ions and provided energies up to 90 q^2/A^2 MeV/A. Later, the energy was increased to 100 q^2/A^2 MeV/A. The cyclotron is now used mainly for heavy ion research. With the internal Penning-type source, the cyclotron provides beams up to $A=40$ with energies high enough for nuclear physics.

In 1975, a major expansion of the facility was begun: the addition of the 25 MV tandem and the ORIC beam injection system. In coupled operation of the two accelerators, using the ORIC as an energy booster, ion energies of 25 MeV/A will be available up to $A \approx 40$ and greater than 6 MeV/A up to $A=200$. In first tests of coupled operation, $^{16}O^{8+}$ ions were accelerated to 400 MeV (25 MeV/A).¹⁾

The superconducting conversion of the cyclotron will give a large increase in beam energies (Fig. 1). For ions heavier than $A=130$, the energy increase is a factor of three, from 100 to 300 q^2/A^2 MeV/A. For ions below $A=130$, the energy is limited by axial focusing considerations to approximately 75 q/A MeV/A. For example, $^{16}O^{8+}$ can be accelerated to 38 MeV/A.

2. Isochronism and focusing.— A preliminary study of the use of superconducting coils on the ORIC was made in 1975.²⁾ Since that time, a remapping of the cyclotron magnetic field was completed. These new measurements, which included data up to $K=100$ have been used in a new computer program that accurately calculates the current settings for the several cyclotron coil systems, taking into account the variable saturation of the pole tip and yoke steel.³⁾ That computer program has been used to predict the magnet characteristics at the higher magnetic fields of the conversion.

With some modification of the program it was possible to determine the effect of geometry changes in the main coils. It was found that a better fit to the isochronous field would be obtained by increasing the radius of the coils and placing them nearer the median plane (Figs. 2 and 3).

[†]Research Sponsored by the Division of Basic Energy Sciences, U.S. Department of Energy, under contract W-7405-eng-26 with the Union Carbide Corporation.

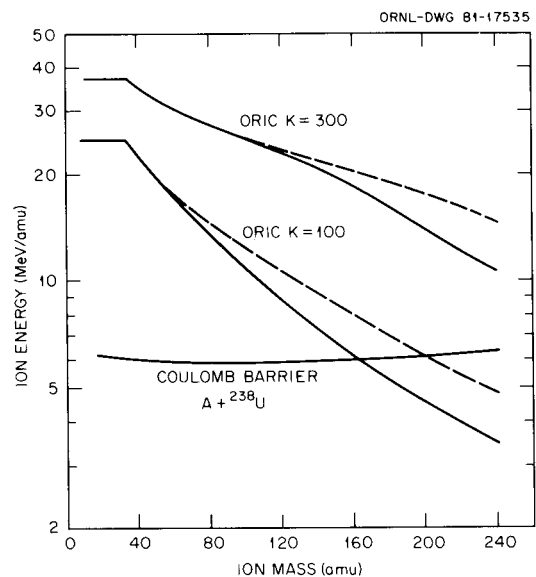

Fig. 1. Beam energies for the ORIC for present coupled operation with the 25 MV tandem ($K=100$) and for the conversion ($K=300$). Solid lines are for gas stripping in the tandem terminal ($\sim 10^{11}$ particle/sec). Dotted lines are for foil stripping in the tandem; to realize practical foil life, operation at lower intensity may be required.

The computer program GFUN-3D⁴⁾ which calculates the magnetic field of complex 3-dimensional coil and iron systems was used to compute ORIC magnetic fields to verify the validity of the extrapolations. GFUN-3D results show good agreement with measurements made at 1.85 T and with extrapolated fields at 3.3 T.

The maximum energy of an isochronous cyclotron may be limited by the average magnetic field ($E = K_B q^2/A^2$ MeV/A) or by the amplitude of the azimuthal variation ("flutter") in the magnetic field ($E = K_f q/A$ MeV/A). The focusing limit occurs near the onset of loss of axial focusing ($\nu_z = 0$). Calculations with the equilibrium orbit code show that K_f for ORIC is approximately 75 MeV. Figure 1 shows the ion energy characteristics of the conversion. Below approximately $A=130$, the energy is limited by focusing.

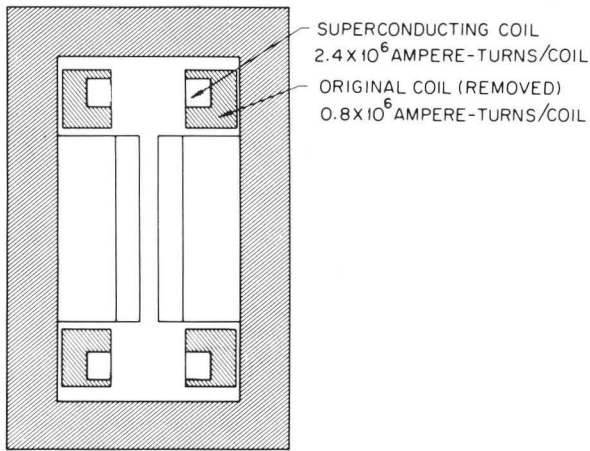

Fig. 2. Changes in coil geometry for the conversion.

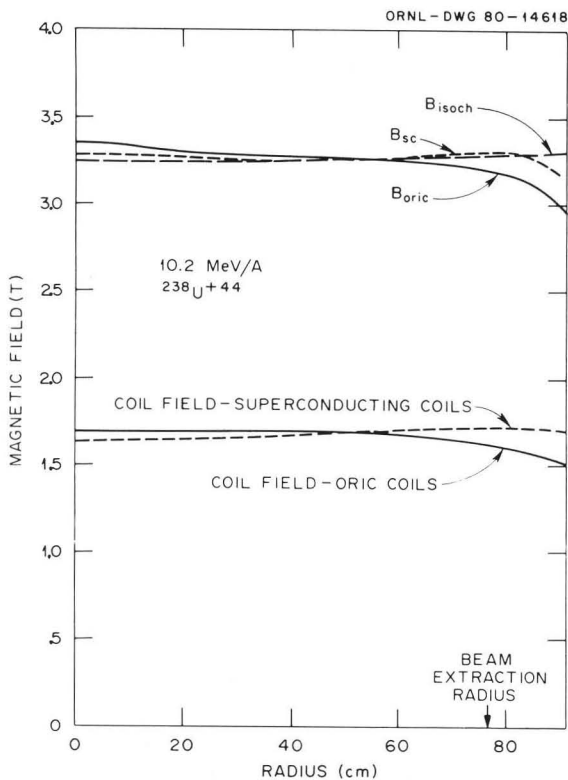

Fig. 3. Average magnetic field for the conversion, showing the improvement in shape with modified coil geometry.

3. Superconducting Coil System.— The superconducting coil system (Fig. 4) was designed to fit in the space now occupied by the aluminum coils and to use the same mounting system. A yoke stiffening system (not shown in Fig. 4) has been designed to accommodate the increased magnetic forces.

Coil design.— The two 0.25-m-wide windings have inner and outer diameters of 2.5 m and 3.1 m. Each winding contains 564 turns of NbTi conductor wound in

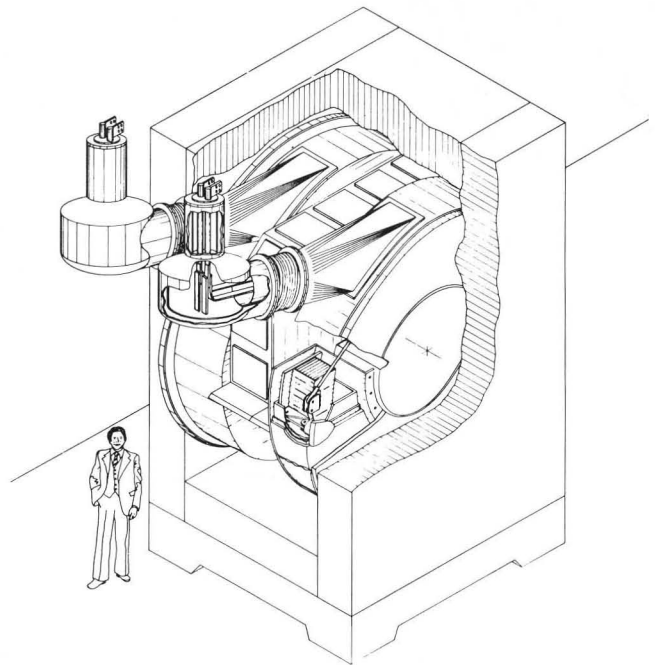

Fig. 4. The superconducting coils will occupy the space presently used by the aluminum coils.

six double pancakes. The conductor (with copper stabilizer) is 2.0-cm wide and 0.5-cm thick. The maximum operating current will be approximately 4300 A. The conductor, designed to be fully cryostable, will be cooled by pool boiling 4.5 K helium from a liquefier. The heat flux at quench is 0.26 W/cm². G-10 epoxy fiber glass insulation is used: 0.12-cm-thick slotted material between turns and 0.16-cm-thick sheet between layers. The stored energy in the system will be approximately 55 MJ.

All features of the coil design incorporate substantial safety factors. The critical current of the conductor is 7000 A. The peak dump voltage is only 150 V and the maximum conductor temperature during quench is estimated to be 104 K. The peak cryostat pressure during quench reaches 7 atmospheres.

Mechanical stresses in the windings have been evaluated with the computer program STANSOL⁵⁾, taking into account stresses from winding preload, cooldown, and magnetic forces. A winding preload of 49 MPa is sufficient to prevent windings from lifting off the bobbin. The maximum tensile stress in the conductor will be 80.5 MPa.

Suspension and Cryostat.— The mechanical suspension for the coils must support the attractive force of 3.9 MN between coils with low heat leakage and deflection, and maintain the coil concentric and coplanar with the median plane to within ± 0.5 mm. The coil forces must be supported from the yoke through the cryostat. The design adopted (Figs. 5 and 6) incorporates epoxy-fiberglass links between the coils at 4 K and the nitrogen shield at 77 K. The nitrogen shield is mounted on short tubular stainless-steel supports from the baseplate at 300 K. Stainless-steel transverse support rods, cantilevered from the tubes, support the 76 kN gravity load and the coil decentering magnetic forces which were calculated to be a maximum of 46.6 kN/cm. The stress safety factors for this

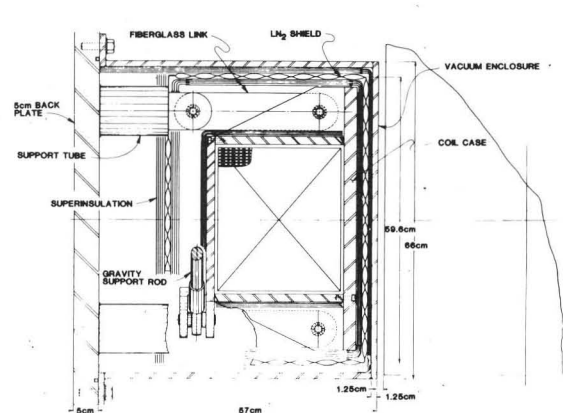

Fig. 5. Cross-section of the cryostat/coil assembly.

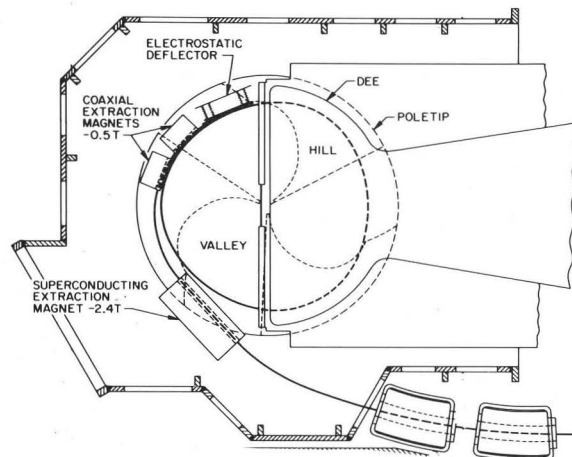

Fig. 7. The beam extraction system for the conversion.

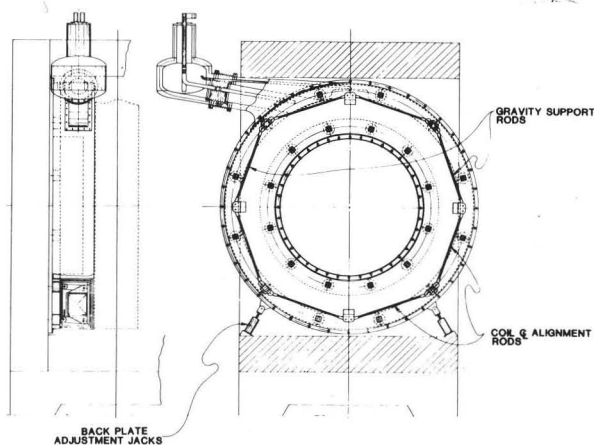

Fig. 6. Side-view of the cryostat/coil assembly.

design are approximately 7 for the epoxy-fiberglass and 3 for the stainless-steel components. The two coils will require approximately 25 L/hr of liquid helium and an equal amount of liquid nitrogen.

4. Beam extraction system.- The preliminary design of the beam extraction system for the conversion is illustrated in Fig. 7. The system consists of a 120 kV/cm electrostatic deflector, two -0.5 T coaxial magnetic channels of the type now in use in ORIC and a -2.4 T superconducting channel. The location and strength of the superconducting channel were chosen to produce a nearly linear beam path; a straight channel may be used with consequent ease of construction. A preliminary design of the superconducting channel (Fig. 8) uses a set of main conductors near the beam region and sets of compensating conductors to cancel the return field of the main winding. The magnetic field outside the channel in the circulating beam region is shown in Fig. 9.

5. Conclusion.- This study has shown that addition of superconducting coils to the ORIC is a practical means of increasing the available beam energies up to a factor of three. In addition to the research benefits, the conversion would reduce the electrical energy consumption by about 1.5 MW. Only minor changes in beam transport systems and shielding will be required for the conversion.

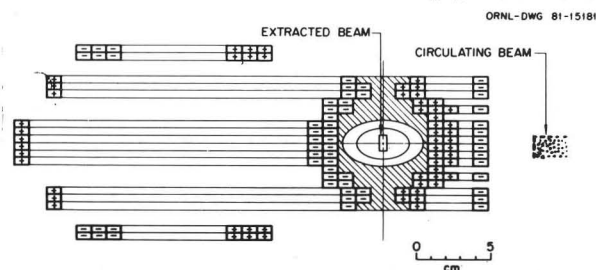

Fig. 8. Conductor distribution for the superconducting channel. Current density is 25,000 A/cm²; peak field is 6T.

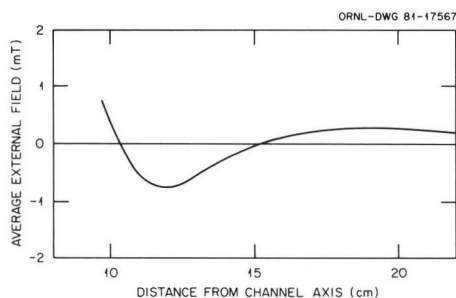

Fig. 9. Magnetic field of superconducting channel in circulating beam region.

References

1. C.A. LUDEMANN, et al., "Initial Operation of ORIC with Tandem Injection," these proceedings.
2. G.S. McNEILLY, et al., Proceedings of the Seventh International Conference on Cyclotrons and Their Applications, Birkhauser, Basel (1975) 626.
3. T.P. CLEARY, IEEE Trans. Nucl. Sci. NS-26, 3097 (1979).
4. A.G.A.M. ARMSTRONG, et al., New Developments in the Magnet Design Program GFUN, RL-75-066 (Rutherford Laboratory, 1975).
5. N.R. JOHNSON, W.H. GRAY, and R.A. WEED, Proc. 6th Symp. on Engineering Problems of Fusion Research.