

RECENT DEVELOPMENTS ON BEAM DYNAMICS IN CYCLOTRONS

P. Lapostolle

*Grand Accélérateur National d'Ions Lourds, B.P. 5027, 14021 CAEN Cedex, France.
Tel.(31)94.81.11 - Telex 170 533 F.*

Abstract.- Starting with the general methods of orbit computations, some attention will be devoted to the properties of orbits over one turn. Next will be considered the problems related to field perturbations, focusing perturbations and perturbations of the medium plane. Eventually invariant or integral properties of the orbits over the whole acceleration process will be examined including various proposals which will be tested on GANIL. High intensity problems treated later at the Conference⁽¹⁾ are not considered here.

1. Introduction.- Cyclotrons are very old machines (the proposal by E.O. Lawrence was made in 1930) and even their most recent form, the so called isochronous cyclotrons, if not currently realized immediately after the principle was set forth by Thomas in 1938 is now generalized since 20 years (about the time when these conferences started).

Almost everything about cyclotrons was known from the beginning and certainly nothing really new and fundamental can now be discovered, but the need for better and better beam qualities, the type of accuracy required by the new superconducting versions and other similar circumstances have however led to more detailed studies, either for instance to improve extraction conditions⁽²⁾, to understand limitations due to non linearities⁽³⁾ and anyway to explore the possibilities of producing better beams.

The purpose of this paper is to briefly review some of these recent efforts, referring mostly to those presented in one form or another at this Conference and on studies developed at GANIL.

2. Orbit computations.- From the development of computers and of more elaborate field mapping devices, have arisen faster and more accurate beam orbit computations. Even if for most of them, nothing basic is new it is however interesting to review some of the lines followed. Worth is also mentioning the possibility offered by present big computers to make beam studies through multiparticle simulation (several tens of macroparticles with a proper statistical distribution).

2.1 Field computation methods.

Efforts have been made for having the possibility to make quick tests on the computer of the effect of changing the geometry of a system, for instance moving elements in the injection area in order to design a new system⁽⁴⁾. Optimization procedures have been developed⁽⁵⁾. Special attention has been put, in particular for the injection region into a superconducting machine, on axial focusing properties⁽⁶⁾.

2.2 Motion in the magnetic field.

The motion in a magnetic field does not present any special problem. Matrix formalism can easily be

used. More general formulae for hard edge approximation in an isochronous machine with variable spiral angles have been derived for the Calcutta project⁽⁷⁾ as well as at Osaka⁽⁸⁾. A slightly new proposal is made at Oak Ridge⁽⁹⁾ for introducing non linear terms through the eikonal function over giant steps of integration (for instance one focusing period or a fraction of period). Such a function can be stored for different radii and used for a fast and accurate computation. This computation to which acceleration is now being added could give a very convenient way to study numerically invariant properties and stability problems.

2.3 Motion in an rf field.

Acceleration process through an rf gap is still subject to evolution on the way it is treated in the computations. If single step uniform field type expressions are still used in an optimization procedure at Julich for fast approximations⁽⁵⁾, a more precise situation is studied with the help of a 3d field relaxation programme. Such 3d codes remain difficult and heavy to handle even with present computers⁽¹⁰⁾; electrolytic tank measurements are still in use⁽⁶⁾ with direct entry to computer.

2.4 rf accelerating gap treatment at GANIL.

An intermediate solution used at GANIL is to express the rf field of an accelerating gap in the form of a Fourier integral with the help of a set of standard EM waves⁽¹¹⁾. The integration of motion of particles inside such a field is then easily done with perturbation methods. Fourier transforms lead to single expressions giving as well classical terms (acceleration, transverse kick) as additional correcting terms if necessary. Since we shall use it later in this report, let us come into more details.

It has already been mentioned⁽¹²⁾ that instead of a single gap, this method can be extended to a complete delta with two gaps situated in a magnetic field free section: for a symmetrical gap of angle 2δ (see fig. 1) with voltage independent of radial position x and gap geometry along the orbit coordinate s also independent of x , the electric field along the s direction can be expressed by the Fourier integral:

$$E_s(s, x, z, t) = \frac{V \cdot \cos(\omega t + \phi)}{2\pi} \int_{-\infty}^{+\infty} \text{ch}(k_z z) \cdot T(k) \cdot \frac{\sin(kx \text{tg}\delta)}{\sin(ks)} \cdot dk \quad (1)$$

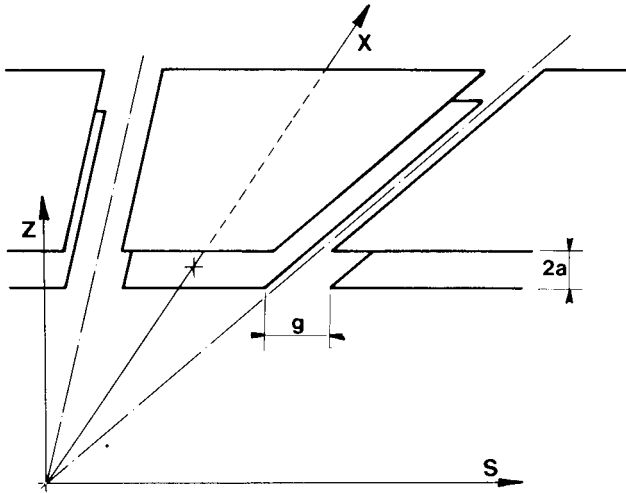

Fig. 1 : Delta shape rf cavity geometry corresponding to the analysis derived in the text. Gap width g , aperture $2a$.

where z is the axial coordinate,

$$k_z^2 = k^2 \cdot (1 + \tan^2 \delta) - \frac{\omega^2}{c^2} = \frac{k^2}{\cos^2 \delta} - \frac{\omega^2}{c^2} \quad (2)$$

and $T(k)$ is the transit time factor of the gap geometry of the delta, for instance $T = \sin(kg/2) / ((kg/2) \cdot \text{ch}(k_z a))$ very close to one for most usual gap values g and apertures $2a$. The expression under the integral sign has the typical form of a component of electromagnetic wave in rectangular coordinates and it is easy to obtain all the other components.

By first order and if necessary higher order⁽¹³⁾ perturbation method⁽¹⁴⁾ it is then possible to express by one term or a few terms the longitudinal and transverse kicks and displacements received by a particle crossing the full delta. Similarly, without much extra complexity it is possible to include in the expression of the field a radial variation of the voltage (along the gap) : provided such a variation is expressed in the form of a few terms of a Fourier expansion, (1) remains of the type of a sum of EM waves (with however different k_z for each of them).

All expressions describing the effect of the delta cavity on a particle of velocity v can then be expressed with respect to the position and rf phase of the particle when crossing the mid plane of the delta. For instance, the particle gets an extra energy ΔW , is displaced in phase by $\Delta\phi$ and receives a radial kick which can be expressed in the following way : putting

$$|\Delta W|(x, z, k) = V(x) \cdot \text{ch}(k_z z) \cdot T(k) \cdot \sin(kx \tan \delta) \quad (3)$$

one has

$$\Delta W = \frac{q}{u} |\Delta W|(x, z, k = \omega/v) \sin \phi \quad (4)$$

$$\Delta\phi = -\frac{q}{u} \frac{1}{2W} \frac{\omega}{v} \frac{\partial}{\partial k} \left\{ |\Delta W|(x, z, k = \omega/v) \right\} \cos \phi \quad (5)$$

$$\frac{\Delta(m v_x)}{mv} = \frac{q}{u} \frac{1}{2W} \frac{v}{\omega} \frac{\partial}{\partial x} \left\{ |\Delta W|(x, z, k = \omega/v) \right\} \cos \phi \quad (6)$$

q is the charge of the particle, u its mass in atomic mass units and energies W are expressed in electron volts per atomic mass unit.

On such expressions one easily finds well known relations like (irrotational property)

$$\frac{\partial(m v_s)}{\partial x} = \frac{\partial(m v_x)}{\partial s} \quad (7)$$

As was shown previously⁽¹²⁾ the effect of the term $V(x)$ on the phase compression or dilatation of a bunch can also be derived easily.

Other delta cavities, with unsymmetrical voltages for instance, could also be considered but \cos terms should be added to the \sin of expression (1). More general expressions with more terms could however be derived. Non straight gaps, except for a very limited number of cases cannot however be treated with this analysis. Nevertheless local properties can still be studied. Relation (7) is very general in a first order perturbation method as can be proved from basic expression of EM field with vector potential.

One of the interest of the previous approach is to provide a link between hamiltonian mechanics properties of the EM field, and extend to rf fields the well known properties of static fields, showing how they are connected with Maxwell's equations. If the previous analysis was derived only for the case of a cavity situated in a magnetic field free region, an extension of it to include the presence of a magnetic field, for instance uniform, might be an interesting tool for the analysis of compact cyclotrons.

3. Properties of the orbits over one turn.- For gaps inside the magnetic field other properties can be derived with the help of various methods and new theories have even been developed⁽¹⁵⁾.

3.1 Effect of spiral gaps.

An important property recently discussed is that a spiral accelerating gap does not perturb the isochronism of trajectories (nor do radial gaps) : the radial kick due to the angle of the spiral exactly cancels out the change in length of the orbit due to the change in azimuth of two successive crossings.

Such a property initially discovered by Mac Millan^(a) was known in several places (among others : T.A. Welton at Oak Ridge, P. Lapostolle at CERN, H. Willax at SIN, ...). A simple derivation of it is given at this Conference by S. Adam⁽¹⁶⁾ with the help of a matrix formalism. Spiral cavities are used in superconducting sector focused cyclotrons and M.M. Gordon⁽¹⁷⁾ has recently given another proof of the same property.

In fact it may happen that spiral delta shape cavities have variable and unequal voltages along their two gaps. Similarly to the analysis described in the previous paragraph such a case may not be reduced to a simple single gap but to a more complex one. Nevertheless as long as one is concerned with local properties

(a) E. Mac Millan who unfortunately did not keep record of it had developed his analysis in response to a proposal for the use of spiral gaps in a classical cyclotron as a method for maintaining isochronism at large radii⁽¹⁷⁾.

the proofs can certainly be extended and thereafter generalized. The matrix formalism is certainly a very efficient tool to treat such complex cases.

3.2 Radial longitudinal coupling. Rotation in the 3d or 4d space.

Another property of the orbits is the coupling⁽¹⁸⁾ between radial and azimuthal motion. Such a coupling is well known and has been already emphasized previously. As shown in a uniform field, the relative motion of two particles in the space dr, dr' (radial), ds (azimuthal length) is a skew ellipse and one has everywhere the relation

$$ds - ds_o = r dr' \quad (8)$$

r being the radius of the orbit.

In a periodic focusing machine, the smooth approximation can be used. If v_r is the radial betatron frequency, the ratio of the amplitudes of dr and dr' in a betatron oscillation is $\kappa = r/v_r$; the ratio of amplitudes of ds to dr is $1/v_r$ and

$$ds - ds_o = \frac{r}{v_r^2} dr' = (r_{ch}) dr' \quad (9)$$

introducing the chromatic radius (r_{ch}).

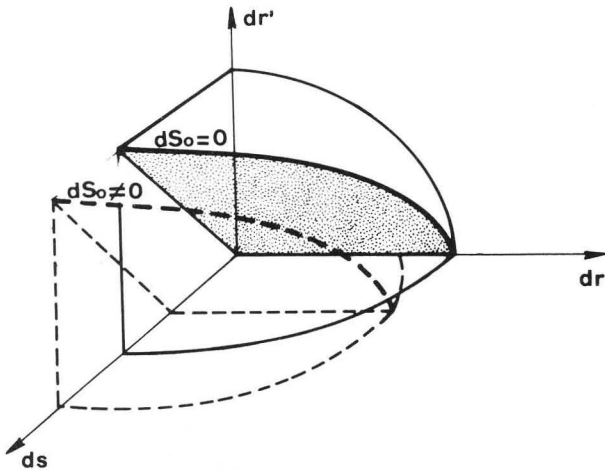

Fig. 2 : Motion of a particle in the smooth approximation of a cyclotron magnetic field. Without acceleration, the fourth coordinate, conjugate to ds is constant. The motion remains in a plane $ds=(r_{ch})dr'+ds_o$. When v_r increases the amplitude of ds with respect to dr decreases as $1/v_r$.

The motion in the space $drdr'$ is still an ellipse (fig. 2) but with different axes.

The smooth approximation is not always very accurate. The true situation, of a sector machine for instance, is more complex; it is easy however, with the matrix formalism to compute, at different azimuths, the ratio of amplitudes, i.e., the β function and the (r_{ch}) = ds/dr' function. This last one is directly related to the chromatic g function through symplectic relations. In the hard edge approximation the chromatic radius does not differ either in mid valleys or mid sectors from the radius r (distance to the center)

by more than 10 % (in the case of GANIL).

3.3 Matching conditions into a cyclotron.

As already emphasized the 4d properties of the orbits have to be taken into account for the adjustment of the position of the beam at injection in r, r' and phase (ds term), energy and also for its matching which must be accomplished with a proper coupling between the radial and azimuthal directions in order to insure the injection into the 4d acceptance⁽¹⁸⁾. Symplectic conditions are such that this matching is possible when starting from an uncoupled emittance in an achromatic line. Furthermore, in particle orbit computations it turns out to be worthwhile to introduce not the usual coordinates but to replace ds by a "corrected coordinate"^(a) which represents the position of the skew plane of motion; the quantity

$$ds - (r_{ch}) dr'$$

is invariant under betatron oscillation and it can be better used to define a "corrected" bunch length and corresponding emittance; one may notice that in phase one is lead to a quantity of the type

$$\phi - k dr'$$

where for the case of radial sectors k is almost independent of radius or energy (like $1/v_r^2$).

Similarly the radial coordinate should be modified and "corrected" for the actual momentum of the particle

$$dr - (r_{ch}) \frac{dp}{p}$$

and accordingly for radial emittance.

The previous coupling properties emphasized for the case of cyclotrons similarly exists for all circular machines. From equation (9) however its importance mainly appears for low v_r machines. Furthermore the coupling of radial betatron with synchrotron rf motion requires rather high harmonic numbers to be appreciable. Such cases may however exist.

4. Field perturbations.

4.1 Centering methods.

The effect of field perturbations for displacing the orbits and methods to achieve a good centering have already given rise to much work in the past around many cyclotrons.

One must just mention a recent work in IPCR⁽¹⁹⁾ for taking into account the distorting effect of rf cavities already described by Adam in 1978 at the European Cyclotron Progress Meeting in Berlin and referred to as GABA effect or lozenge effect⁽¹²⁾.

The most important facts to report may be efforts towards centering and matching into a cyclotron an axially injected beam. Some of this work has already been referred to for orbit computations in sec.2.1. Much work is being devoted to this problem in particular in Kalsruhe, Louvain-la-Neuve, Julich⁽⁵⁻²²⁾ and

(a) In a new analysis of particle orbits in a cyclotron⁽²⁰⁾ M.M. Gordon has derived similar considerations. Such a line had in fact also been used by W.M.Schulte⁽²¹⁾ but the hamiltonian formalism he is using partly obscures the physical facts.

Groningen⁽²³⁾ and another report of this Conference is devoted to the subject⁽²⁴⁾. Many ingenious schemes are being studied. One of the difficulties is that over the previously mentioned (dr, dφ) coupling is now added a (dz, dψ) coupling.

4.2. Centering studies at GANIL.

For centering at injection into a sector focused machine the previously reported methods developed at Vicksi⁽²⁵⁾, SIN⁽²⁶⁾, Triumf⁽²⁷⁾ are being refined at GANIL to take into account special circumstances encountered there.

The method uses three probes in three of the four sectors, measuring the position of the beam over two successive turns :

$$r(\theta) = r_{\text{ref}}(0) + a \cdot \sin(\theta + \phi) + b \cdot \sin(\nu_r \theta + \psi) + \frac{\sigma(\theta)}{2\pi} \theta \quad (10)$$

where over the reference initial orbit $r_{\text{ref}}(0)$ are superimposed the orbit perturbation $a \cdot \sin(\theta + \phi)$ due to field errors to be corrected, unknown betatron oscillation $b \cdot \sin(\nu_r \theta + \psi)$ and the spiralling term in σ .

This last term, instead of being proportional to θ , may in GANIL depart from linearity and even not be well known for two reasons :

- due to the large turn to turn separation the orbits are strongly perturbed by the rf acceleration (Loenze effect) the amplitude of the perturbation (of second harmonic) being proportional to the energy gain per turn ;

- if bunch length compression is used (see sec.7.1) the energy gain per turn will change very quickly from turn to turn according to a law which is theoretically known but depends critically in practice on the exact initial phase and centering adjustments.

The method assumes well known the value of ν_r since its vicinity to 1 controls the amplitude of first order oscillations. Field errors (to be corrected, but unknown) may affect ν_r , and compression also changes its value.

All these effects limit the accuracy of the centering method. What was aimed at in GANIL was to test the possibility of including a determination of the σ law in order to obtain a better reference trajectory including correcting terms on σ and accordingly to make an estimate of the limits of accuracy to expect.

Computer simulations were made on an accelerated beam orbiting in a magnetic field measured in the GANIL SSC's isochronized with trim coils, with the injection elements and their correcting shims, with or without the field perturbation for bunch compression and with or without an additional first harmonic field perturbation (of the type to be used for centering the orbits).

No definite conclusion can be drawn yet and only after true beam experiments real processes will be derived. The following remarks can however be done :

- when checking the phase of the particles in order to adjust isochronism or another phase law (for compression) and to estimate acceleration (and the law of σ versus radius) one is led to forget about the coupling between radial and azimuthal motions ; this is less and less correct when the rf harmonic goes up ;

- one forgets about field perturbation harmonics other than 1 ;

- one assumes not too fast an acceleration to justify an adiabaticity hypothesis ($\sigma = 60$ mm is very large and leads to bad results ; 30 mm is a limit for a reasonable accuracy) ;

- one assumes a slow radial variation of perturbations (which is not the case for the injection elements and their correcting shims) because, otherwise, the amplitudes a and b of orbit perturbation and betatron oscillations quickly change from turn to turn and ν_r is also modified :

- one makes use of differences between orbit positions ; the accuracy of the probe measurements limits the accuracy to which centering can be adjusted.

It is estimated that the method is efficient for correcting orbit perturbations or misalignments for oscillations between 5 and 30 millimetres. Experiments with the beam are however needed to confirm these figures.

5. Gradient perturbations. Radial motion.-

5.1. Magnetic field perturbations.

Field gradients affect focusing properties of the magnets and hence matching conditions.

The necessity of keeping isochronism or a smooth phase law insures some average conservation of gradients. It does not exclude however the possibility of harmonic gradient perturbations. Amongst them second harmonics are the most severe in cyclotrons where $\nu_r \approx 1$.

The effect of a gradient perturbation is to open a stop-band of instability around $\nu_r = 1$ ⁽²⁸⁾; close to the edge of this instability region however, where the orbits are still stable, focusing properties can be appreciably changed and matching conditions may be difficult to satisfy. In the case of GANIL where $\nu_r \approx 1.07$ at injection the opening of a stop-band of ± 0.035 (half way of the initial margin) quite appreciably affects matching conditions.

Gradient perturbations may be corrected by properly excited trim coils. In the case of a four sector machine however, and excitation of the type +--+ of the sectors can produce a well behaved second harmonic field and gradient correction, but its phase is rigidly fixed. If the perturbation is due (as in the case of GANIL) to an injection magnet which mainly affects the field in one valley (by producing a fast drop near the injection radius) the trim coils are totally inefficient for correction.

Such a valley perturbation could be corrected, for orbit perturbation only (first order), by an equal perturbation diametrically opposite. As far as focusing and stop-band are concerned, however, the effect would be doubled.

The procedure used at GANIL has been to try to correct the perturbation by shims installed as close as possible to the magnet which produces it. Field measurements are completed with a computation of the remaining second order focusing force amplitude and phase and a computation of the resulting stop-band⁽²⁸⁾. The rule of keeping that one well below half the original margin and preferably not more than one third or one fourth has been adopted (see sec.5.2).

An effort on a similar subject is being developed on the project SUSE at Garching. There the injection line being in one scheme above the median plane the

field correcting problem requires also the consideration of the axial direction with symmetry restoring elements⁽²⁹⁾.

5.2. rf cavity perturbations.

One strong source of second order perturbation can be rf cavities. The importance of this effect was already reported before and its analysis given at several instances⁽³⁰⁻³¹⁻¹⁵⁾.

The exact computation of one orbit including the acceleration through a two delta system in a four sector machine can be obtained with the help of matrix formalism. An approximate expression was given⁽³¹⁾ relating the dr and ds coordinate after one turn to the initial values taken in an rf free valley ; it can be expressed in the form (to first order in A) :

$$\begin{cases} dr_1 \approx (\cos 2\pi\nu_r + 2A) dr + \frac{\beta}{(r_{ch})} \sin 2\pi\nu_r ds \\ ds_1 \approx -\frac{(r_{ch})}{\beta} \sin 2\pi\nu_r dr + (\cos 2\pi\nu_r - 2A) ds \end{cases} \quad (11)$$

with $A = \frac{\Delta W}{2W} \cdot \phi \cdot \cotg \delta$ (12)

and $\phi = h \cdot \frac{r_{vall}}{R} \cdot \tg \delta$ (13)

where β is the usual β function, (r_{ch}) is the chromatic radius previously introduced⁽⁹⁾, h the harmonic frequency factor, r_{vall} is the mid valley radius (in the mid delta plane), R is the average radius of the orbit and δ half the angle of the delta cavity ; ϕ is then the phase drift between the mid plane of a delta and each gap ; ΔW is the energy gain over one delta^(a).

The stroboscopic view at a fixed azimuth (mid free valley) of oscillations of the previous type looks like smooth oscillations governed by the set of differential equations :

$$\begin{cases} \frac{d(dr)}{d\theta} = kdr + \frac{\beta}{(r_{ch})} ds \\ \frac{d(ds)}{d\theta} = -\frac{(r_{ch})}{\beta} dr - kds \end{cases} \quad (14)$$

with $k = A / \pi(\nu_r - 1)$ (15)

It then appears that the rf cavities can introduce an instability and open a stop-band exactly like field gradient errors do and we shall compute later the magnetic field error equivalent to the rf cavities.

Before that however let us look at some of the properties of equ.(14) and (15) which offer a good insight into the orbit situation near a stop-band.

One easily finds that the presence of the k term reduces the beat frequency by the factor $\sqrt{1 - k^2}$; the motion then becomes unstable for $|k| = 1$, i.e.

$$\Lambda / \pi = \nu_r - 1 \quad (16)$$

Furthermore before that instability is reached the motion in the dr, ds plane instead of being a circle (with the proper scaling) becomes a skew ellipse of

(a) Taking the gain per turn, the factor 2 should be dropped in front of A in equ.(11).

axis ratio $\sqrt{(1 + |k|)/(1 - |k|)}$. If the 4d matching is not properly corrected, envelope oscillations will appear with a max/min amplitude equal to $\sqrt{(1 + |k|)/(1 - |k|)}$. This exemplifies the necessity of remaining far enough from the edge of the stop-band and justifies the rule given above of not admitting the opening of a stop-band filling more than half the margin $\nu_r - 1$ ($|k| = 1/2 : \sqrt{(1 + |k|)/(1 - |k|)} = 1.732$) and preferably only one third (...1.414) or one fourth (...1.291).

For high harmonic frequency factors, ϕ can be very large (several radians) and according to its exact value A may no longer be negligible (being either > 0 or < 0).

It then becomes very interesting to find out whether there exists a magnetic field gradient perturbation having an effect of the same nature as that of rf cavities and such that applied with the opposite sign it would cancel their effect⁽³²⁾.

Let us for that consider the perturbation of thin lenses of vergence $\pm \Delta$ applied in the middle of each of the four sectors (see fig.3). Computing the matrix dr, dr' over one turn starting from a mid valley point, one finds for the diagonal terms, limiting the expansion to third order in $\beta\Delta$, $(\nu_r - 1)$:

$$\begin{aligned} \cos 2\pi(\nu_r - 1) \pm 2\beta\Delta \cdot \cos \pi(\nu_r - 1) \cdot \cos^2(\pi(\nu_r - 1)/2) \\ + \beta^2 \Delta^2 (2 \mp \pi(\nu_r - 1)/2) \mp \beta^3 \Delta^3 \end{aligned}$$

To first order, there is the equivalence

$$\beta\Delta \equiv A$$

and the check of the trace of the matrix shows that the stop-band opening is

$$\beta\Delta / \pi \equiv A / \pi$$

in agreement with (16) ; this justifies the above developments. The rf cavity effect can be cancelled by a perturbation in the sectors.

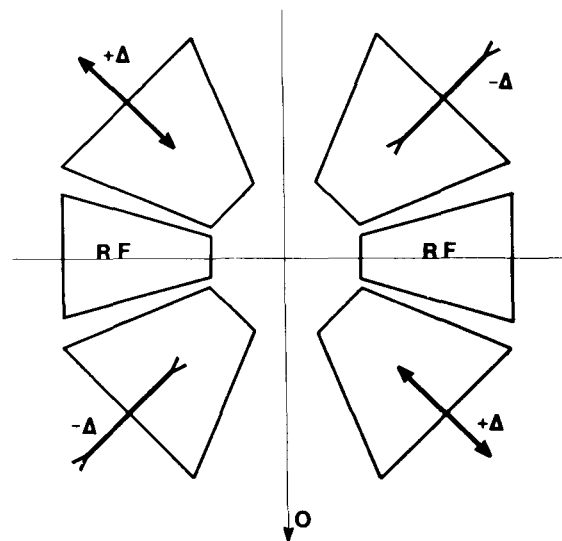

Fig. 3: Thin lens compensation scheme of the gradient perturbation produced by rf cavities. Equations given correspond to one turn starting and finishing at azimuth 0.

In order to refine the computation of the field produced by trim coils which would compensate the rf cavity effect, one should use Courant and Snyder theory⁽²⁸⁾.

Considering that a flat sector has already a focusing effect, the total focusing strength in the equation

$$\ddot{x} + g(s)x = 0 \quad (17)$$

is given by

$$g(s) = \frac{B^2 + (\rho B)\partial B/\partial n}{\bar{B}^2} \quad (18)$$

where B is the local magnetic field (ρB) is the mv/q of the particle, $\partial B/\partial n$ is the gradient normal to the trajectory and \bar{B} is the average field over one turn.

Assuming the bare machine is such that $\partial B/\partial n = 0$ and that one is adding with trim coils a correction ΔB , one has

$$\Delta g(s) \approx \frac{2B \cdot \Delta B + (\rho B)\partial \Delta B/\partial n}{\bar{B}^2} \quad (19)$$

In order to produce a second harmonic effect counteracting the rf perturbation one should have in the sectors of width 2θ taking into account the exact terms appearing in the derivation of Courant and Snyder⁽²⁸⁾

$$\frac{2B}{(\rho B)} \cdot \Delta B + \frac{\partial \Delta B}{\partial n} = A \frac{R/r}{2\theta} \frac{h_{111}}{B} \quad (20)$$

From (12) with a voltage on the gaps independent of r (20) can be written forgetting the difference between ρ and r in the first term :

$$2 \frac{\Delta B}{r} + \frac{d\Delta B}{dr} = \frac{k_1}{r^2} \quad (21)$$

$$\text{with } k_1 = A \frac{R_0}{2\theta} \frac{R_0}{\beta_0} \quad (22)$$

indices referring to values at injection.

The general solution of (21) is

$$\Delta B = \frac{k_1}{r} + \frac{C^t}{r^2} \quad (23)$$

By a proper choice of the C^t one can make the perturbation ΔB equal to zero near injection, extraction or at any intermediate radius.

A perturbation like (23) would in principle cancel completely the effect of rf cavities.

For GANIL however the rf cavity perturbation is serious for the operation on $h=14$; a numerical estimate of ΔB given by (23) gives very large field values. As previously explained, fortunately, it is not necessary to cancel completely gradient perturbations but only to reduce them to an acceptable level. Since the rf perturbation decreases with radius one can make correction only up to a certain radius r_1 where the stop-band width is small enough and replace equ.(21) by

$$2 \frac{\Delta B}{r} + \frac{d\Delta B}{dr} = \frac{k_1}{r^2} - \frac{k_1}{r_1^2} \quad (24)$$

of which the solution such that $\Delta B(r_1) = 0$ is :

$$\Delta B = \frac{k_1}{r} - \frac{k_1 r}{3r_1^2} - \frac{2k_1 r_1}{3r^2} \quad (25)$$

A few computer simulation runs have been made with such corrections and shown a reduction of the effect of the rf perturbation on the motion in (dr, ds) plane. Further studies would still however be needed and only tests with beam will eventually give a conclusive answer on the interest of such a compensation method.

6. Axial motion perturbation.— In most of the designs one assumes a perfect symmetry of all the machine components with respect to the so-called median plane.

Any axial asymmetry can reduce axial acceptance⁽³³⁾. The effect however is particularly big when $v_r \neq 1$.

The case of crossing $v_z = 1$ resonance is met at IUCF. A method has been studied there and found satisfactory⁽³⁴⁾ ; by providing slightly different currents in the top and bottom coils of the four individual sector magnets, the beam is kept near the median plane and moving the magnet yokes physically has not been necessary. (See a note at the end of the paper)

7. Integral and invariant properties.—

7.1. Bunch length compression.

The reduction of energy spread in a cyclotron if no flat topping is used requires a reduction in bunch length.

If one wants not to lose intensity by cutting the edges of the bunch, some manipulation or matching in longitudinal phase space must be achieved.

Such a manipulation can be made before injection ; one may also think of doing it inside the cyclotron itself.

Muller and Mahrt⁽³⁵⁾ had indicated more than ten years ago that such a compression in phase is possible provided the energy gain per turn is strongly increased after injection. They had shown the existence of the invariant

$$\Delta W \sin \Delta \phi = C^t \quad (26)$$

where $\pm \Delta \phi$ is the bunch length and ΔW the energy gain per turn.

In order to change ΔW (see equ.(3) and (4)) one might think of having either a variable voltage V along the gap (but a fast variation is difficult to produce) or a variable transit time factor T of the gap (by a change in gap length or aperture, not very convenient either). Another possibility would be to change the delta angle but that would lead to a situation where the factor A defined by equ.(12) would be great and the rf perturbation open a wide stop-band. Anyway any device of one of these types would be fixed and offer no flexibility for optimizing compression factor : this optimum obviously depends on the exact longitudinal phase space distribution of the bunches⁽³⁶⁾.

The method proposed by P.Yvon and considered at GANIL⁽³⁶⁾ makes use of an average field perturbation ΔB producing a slip of the phase of the bunch centre just after injection. The bunches are then injected, say 50° or 70° ahead of the optimum phase and then moved in phase toward the maximum gain position.

From the invariant of motion :

$$qV \sin \phi + \int 2 \pi h (\Delta B_0(W)/B_0) dW = C^t \quad (27)$$

and considering two particles of central phase ϕ_c separated by small $\Delta \phi$, ΔW , a comparison between input and output gives :

$$\begin{cases} [qV \cos \phi_c \Delta \phi + 2\epsilon h (\Delta B_o/B_o) \Delta W]_{out} = \\ [qV \cos \phi_c \Delta \phi + 2\epsilon h (\Delta B_o/B_o) \Delta W]_{in} \end{cases} \quad (28)$$

Assuming for instance $\Delta B_{out} = 0$ and the two particles of the same initial energy ($\Delta W_{in} = 0$) one gets :

$$(V \cos \phi_c \Delta \phi)_{out} = (V \cos \phi_c \Delta \phi)_{in} \quad (29)$$

In order to minimize the final energy spread, the phase after compression is made slightly positive in such a way that the average phase be zero (see fig. 4).

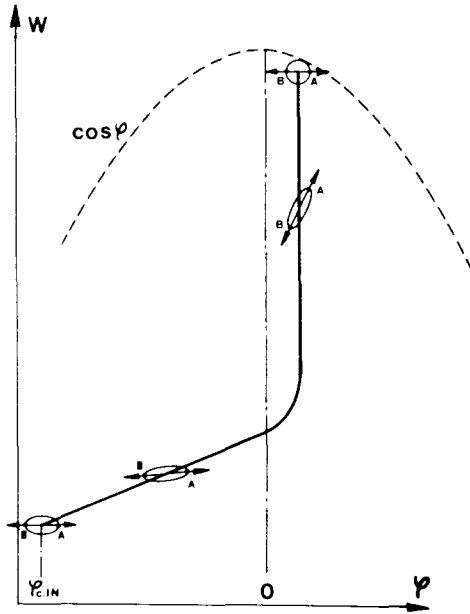

Fig. 4: Basic bunch length compression scheme. The central phases move after injection from a large negative value to a value close to the maximum of acceleration; the exact final value is such that particles A (head) and B (tail) have the same energy at output.

7.2. Longitudinal to radial coupling.

A difficulty arising in the application of the previous bunch compression method is that the turn to turn separation is reduced at injection by a factor about equal to that of the compression foreseen. Injection, especially for high energy machines where this separation is naturally small becomes impossible without special tricks. One of them is to use precessional injection. This is what is foreseen in GANIL SSC2.

A precession of about 2.5 cm amplitude insures, for the case of GANIL, very good injection conditions.

Left until extraction such an oscillation could advantageously replace for ejection the orbit separation otherwise produced by a field bump. Such a mixed device looks a priori very attractive.

Computer simulation tests however showed that while the longitudinal phase space behaved correctly the radial emittance exhibited a large increase⁽³⁶⁾. This is due to a phenomenon already analysed under different circumstances by W.M. Schulte⁽³⁷⁾. In a high energy cyclotron the v_r increases with energy, due to

relativistic isochronism corrections. In case, as in fig.4, head particles have always an energy slightly higher than tail particles they will make more precessional oscillations.

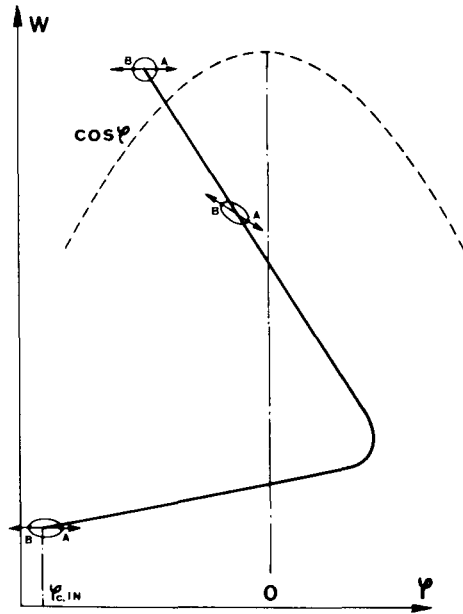

Fig. 5: Modified bunch length compression scheme for minimizing output radial emittance when precession is used. Head and tail (A and B) particles must have the same energy at output ; in addition their average relative energy during acceleration must be equal.

A study of this effect⁽³⁶⁾ led to use a phase law as shown on fig. 5, which is obtained by only a very slight increase δB_o of the magnetic field after compression (a few gauss). The behaviour, during acceleration, of a well adjusted beam is shown on fig. 6 while fig. 7 gives the output radial emittance, bunch length and energy spread as function of the injection phase for various values of the small field correction δB_o .

Injection phase and field adjustments can be based on a comparison between input and output. The accuracy required is not higher than without compression nor precessional injection⁽³⁸⁾. Electronic control through computer could be used when more experience is gained.

The progressive increase of radial emittance during acceleration still seen in fig. 6 is of the nature of the phenomenon studied by W.M.Schulte as previously mentioned. It is due to the energy difference between central particles and the average between head and tail, difference produced by the non linear form of a sinusoidal accelerating field. This slight increase, proportional to the precessional amplitude could be cancelled, as shown by Schulte by a proper reduction of v_r before extraction⁽³⁷⁾. Such a scheme has not been tested at GANIL.

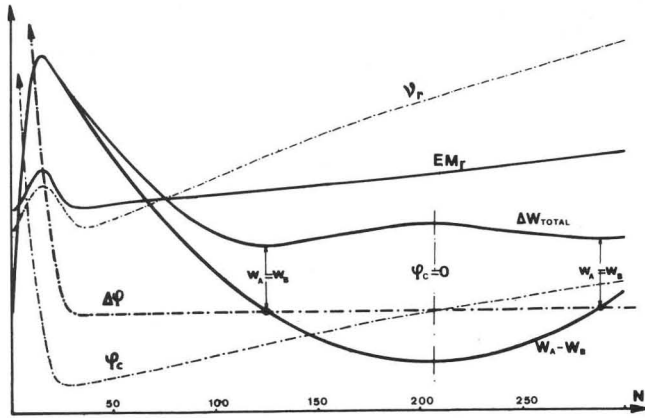

Fig. 6: Mechanism of radial emittance growth compensation. One may notice that :
 - v_r increases almost linearly with the number N of turns except at the beginning of acceleration due to compression field perturbation .
 - ϕ_c (central phase) follows a law of the type shown on figure 5.
 - $\Delta\phi$ (bunch length, "corrected" according to sec.3.3.) is compressed fast and stays constant during the rest of acceleration.
 - $W_A - W_B$ (head to tail energy difference) comes to a large value during compression ; it then goes through zero becomes negative and comes back to zero at the end of acceleration. ΔW total bunch energy spread.
 - Radial normalized emittance (EM_r), "corrected" according to 3.3., increases slowly as explained at the end of sec.7.2.

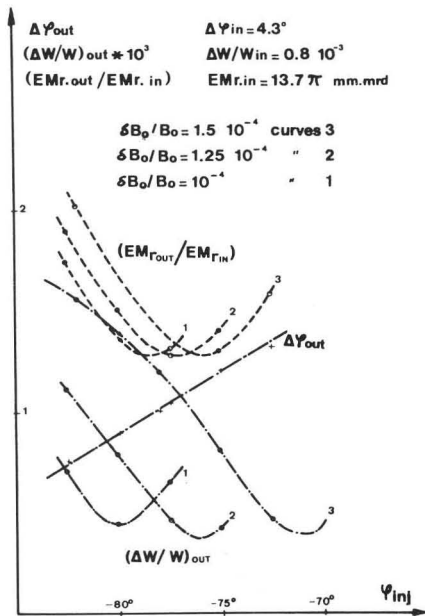

Fig. 7: Effect on radial normalized emittance and on total energy spread of a change in injection central phase ϕ_c and in compensation field δB_0 :
 $\phi_{c \text{ in}} = -77^\circ$ on curve 2 gives a good operation, corresponding to fig. 6. Tolerance of adjustments appears clearly.

7.3. Axial to longitudinal coupling.

Axial oscillations slightly affect acceleration for two reasons. One is through the change in length of the orbits and hence the progressive change in phase of acceleration when particles perform axial oscillations. Another is because transit time factor through an accelerating gap depends on axial position (mainly at low energy). These two effects are quadratic in terms of oscillation amplitude a : the relative orbit length increase is $1 + \frac{1}{2} \frac{a^2}{\lambda_z^2}$ where $\lambda_z \sim 2\pi R/v_z$ is the axial betatron wavelength. The relative energy gain increase is $1 + a^2 h^2 / 4 R^2$.

The resulting effect, analyzed for the case of GANIL turns out to be very small. The change in output energy after N turns of acceleration for a particle of initial phase ϕ_{in} performing axial oscillations of assumed fixed amplitude a and frequency ν_z is given approximately by⁽³⁹⁾ :

$$\delta W \sim \left\{ \frac{h(W_{ex} - W_{in})}{2 \pi \nu_z^2 N} + \left[W_{ex} \left(\ln \frac{W_{ex}}{W_{in}} - 1 \right) + W_{in} \right] \phi_{in} \right\} \delta \phi$$

with

$$\delta \phi = 2 \pi N h \frac{\nu_z^2 a^2}{4 R_{in}^2} \frac{W_{in}}{W_{ex} - W_{in}} \ln \frac{W_{ex}}{W_{in}}$$

where $\delta \phi$ is the phase slip during acceleration.

The result of a computer simulation is shown on fig. 8 for a bunch having twice the normal axial amplitude statistical distribution.

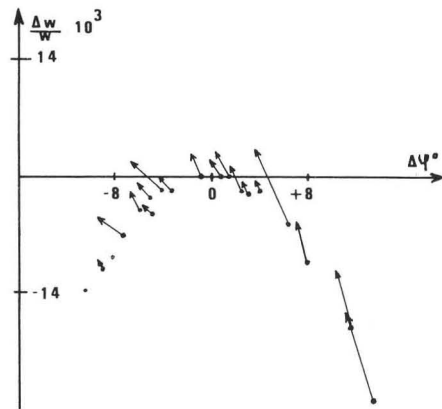

Fig. 8: Effect of axial motion on the longitudinal phase plane. The arrows indicate the difference in output phase space position of a bunch simulated by randomly distributed particles with versus without axial motion (random). Both bunch length and axial amplitude have been enlarged to magnify the effect.

8. Concluding remarks.- By way of conclusion, a few remarks may be made. Let us first consider the bunch compression process studied at GANIL. It is based on one of the first invariants derived for cyclotron motion ; more than ten years ago, Muller has made a proposal for producing a similar effect via voltage gradient. So, neither the basis nor the idea is new. A more complete analysis, including injection problems and longitudinal to radial phenomena however presents a situation such that without detailed computation and without any pos-

Proceedings of the 9th International Conference on Cyclotrons and their Applications
September 1981, Caen, France

sibility of precise adjustments there would have been no hope of obtaining any useful result.

Consider now the 4d motion of a particle in a cyclotron field. This was well known by cyclotronists (if not by synchrotronists) from the early years. The phenomenon is not however usually described in books and not much attention was paid to it for years neither for beam measurements nor for matching.

One can say that one of the facts acting toward cyclotron theory development is computer facility progress. Simulation experiments, which are now possible, permit observation of phenomena and effects which would be unaccessible to experiments because they are mixed with others or are too small to be detected. Optimizations can then be done which would be completely des-pairing otherwise.

Another fact is of course improvement of technology where tolerances of fabrication, stability of operation reach levels formerly unconceivable.

One of the most important aspects, however, is probably improvement of diagnostics.

Without diagnostics it would be unthinkable of trying to observe or exploit many of the effects discussed. Even the limitations of present diagnostics will often prevent from obtaining as good a performance as computer simulation let expect. Their improvement on the other hand justifies new research and can open new fields of development.

To some extent one can say that after first order properties there are second or higher order properties which are more and more studied and appear more clearly in the operation. In computer simulation the use of second order quantities (r m s dimensions or emittances) turns out to be extremely significant in the analysis of phenomena. Any advance in the development of diagnostics and methods well suited for the measurement of these second order values might lead to a greater coupling between theory and experiments.

In any case more and more progress will result from interaction between good measurements and good computations.

9. Acknowledgements.- The present report does not intend to give a complete nor exhaustive review of all the theory developed about cyclotrons over the last few years. Through the submitted abstracts and other work the author was aware of, it tries to show some convergence of efforts and bring some light over old facts, leaving to theoreticians lines of research.

The present review has probably forgotten important facts, it may have very improperly quoted others and for any original work presented, the author is indebted to many other coworkers.

Should all of them find here his acknowledgements and his apologies for omissions and errors.

10. References.-

- (¹) W. Joho, High intensity problems in cyclotrons. This conference.
- (²) E.W. Blackmore, D.A. Dohan et al. Developments toward separated turns at TRIUMF. This Conference.
- (³) W.G. Davies. The effects of noise and buncher nonlinearities in the production of very short beam bunches. This Conference.
- (⁴) A. Goto, Y. Yano et al. Calculation of injection orbit in the IPCR SSC. This Conference.
- (⁵) L. Aldea, J. Reich, P. Wucherer. The modified center region for the project ISIS at Julich. This Conference.
- (⁶) F. Marti, M.M. Gordon et al. Design calculations for the central region of the NSCL 500 MeV superconducting cyclotron. This Conference.
- (⁷) N.C. Bhattacharya, A.S. Divatia. Orbit dynamics for AVF cyclotrons in hard edge approximation. This Conference.
- (⁸) M. Inoue. Simple estimation of focusing properties of an SSC with soft edge and non zero gradient field. 1981 Part.Accel.Conf.Washington IEEE NS 28 n° 3 pp 2596.2598.
- (⁹) T.A. Welton, T. Nichols. Orbit dynamics in isochronous cyclotrons. 1981 Part.Accel.Conf.Washington IEEE NS 28 n° 3 pp 2480.2482.
- (¹⁰) Mao Bai Chen, D.A. Lind. The numerical calculation of the 3d electric field in the central region of a cyclotron. 1981 Part.Accel.Conf. Washington IEEE NS 28 n° 3 pp 2636.2638.
- (¹¹) A. Chabert, G. Gendreau, J. Sauret et al. Etude théorique et numérique de l'accélération des particules dans les CSS du GANIL. GANIL int. report 77.005.TP.01.
- (¹²) A. Chabert, G. Gendreau, P. Lapostolle. Limited energy spread in an SSC. Eighth Int. Conf. on Cycl. Bloomington 1978. IEEE Trans NS 26 n° 2 p. 2306-2311.
- (¹³) A. Carne, P.M. Lapostolle, M. Promé. Accurate beam dynamics equations in proton linear accelerators. Fifth Int. Conf. on H.E. Acc. Frascati 1965, pp. 656-662.
P.M. Lapostolle. Dynamique dans les accélérateurs. Gain d'énergie, déphasage et mouvement radial à la traversée d'un espace d'accélération. CERN. Int. report AR/Int. SG/65.11.
- (¹⁴) B. Schnizter. General properties of fields and beam dynamics in a linac gap, CERN report 69-3. Hamiltonian mechanics with a space coordinate as independent variable. Canonical thin lens approximation for an accelerating gap, CERN report 70.7.
- (¹⁵) W.M. Schulte, H.L. Hagedoorn. The theory of accelerated particles in cyclotrons. Nucl. Inst. and Meth. 171 (1981) pp. 409.437.
- (¹⁶) S. Adam. New proofs and old facts in accelerating theory. This Conference.
- (¹⁷) M.M. Gordon. Effect of spiral electric gaps in superconducting cyclotrons. Nucl. Inst. and Meth. 169 (1980) pp. 327-336.
- (¹⁸) N. Nakanishi, A. Goto et al. Beam dynamics of the IPCR SSC. This Conference.
- (¹⁹) Y. Yano, A. Goto, N. Nakanishi. Initial conditions for well centered orbit in a cyclotron. This Conference.
- (²⁰) M.M. Gordon, F. Marti. Radial longitudinal coupling in cyclotrons and focusing complementarity. MSU report to be published.
- (²¹) W.M. Schulte, H.L. Hagedoorn. The definition and the use of the central position phase in cyclotrons. Eighth Int. Conf. on Cycl.Bloomington 1978, IEEE Trans NS 26 n° 2 pp. 2388-2391.
- (²²) R.K. Bhandari, J. Reich. The Beam handling and

- axial injection system for the project ISIS at Jülich. This Conference.
- (23) W.K. Van Asselt, O.C. Dermais et al. The axial injection system at the KVI. This Conference.
- (24) G. Ryckewaert. Axial injection system in cyclotrons. This Conference.
- (25) G. Hinderer. Automatic isochronisation and computer aided centering in the VICKSI cyclotron. Eighth Int. Conf. on Cycl. Bloomington 1978, IEEE Trans NS 26 n° 2, pp. 2355-2357.
- (26) W. Joho, S. Adam. Setting up of the SIN 590 MeV ring cyclotron for single turn extraction. Eighth Int. Conf. on Cycl. IEEE Trans. NS 26, pp. 2358-2361.
S. Adam, J.C. Collins. Automatic centering and matching of cyclotron beams. loc. cit. pp. 2362-2365.
- (27) E.W. Blackmore, M.K. Craddock, G. Dutto et al. Measurements and corrections to the beam properties in the TRIUMF Cyclotron. Eighth Int. Conf. on Cycl. Bloomington 1978, IEEE Trans NS 26 pp. 2371-2374.
- (28) E.D. Courant, H.S. Snyder. Theory of the A.G. synchrotron. Ann. of Physics vol. 3 1958 p. 1-48.
- (29) W. Schott. Status report on SUSE. This Conference.
- (30) W.M. Schulte, H.L. Hagedoorn. Accelerated particles in an AVF Cyclotron with a one or two dee system. Eighth Int. Conf. on Cycl. Bloomington 1978 IEEE Trans NS 26 n° 2 pp. 2329-2333.
- (31) A. Chabert, J. Fermé, P. Lapostolle et al. 1979 Part. Accel. Conf. San Francisco IEEE NS 26 n° 3 pp. 3612-3614.
- (32) A. Chabert, G. Gendreau, P. Lapostolle. Excitation d'instabilités. Défauts de gradient dans GANIL. GANIL Int. Report 81R/020/TP/02.
- (33) J.J. Botman, H.L. Hagedoorn. Median plane effect in the Eindhoven AVF cyclotron. 1981 Part. Accel. Conf. Washington IEEE NS 28 n° 3 pp. 2128-2130.
- (34) D.L. Friesel, J. Dreisbach. Crossing the $v_z = 1$ resonance in the IUCF main tige. This Conference.
- (35) R.W. Muller, R. Mahrt. Phase compression and phase dilatation in isochronous cyclotrons. Nucl. Inst. and Meth. 86 (1970) pp. 241-244.
- (36) A. Chabert, G. Gendreau, P. Lapostolle, P. Yvon. Bunch length compression inside an SS Isoch. Cycl. and related problems. 1981 Part. Accel. Conf. Washington IEEE NS 28 n° 3 pp. 2122-2124.
- (37) W.M. Schulte, H.L. Hagedoorn, C.J.A. Corsten. A method to obtain single turn extraction for a large phase width in cyclotrons. Eighth Int. Conf. on Cycl. Bloomington 1978. IEEE Trans NS 26 n° 2 pp. 2392-2395.
- (38) A. Chabert, G. Gendreau, P. Lapostolle. Augmentation d'émission radiale dans le processus de compression de phase par défaut d'isochronisme. GANIL int. report 80R/142/TP.09.
- (39) A. Chabert, G. Gendreau, P. Lapostolle. Effet des oscillations axiales sur la dynamique des particules dans les CSS du GANIL. GANIL int. report 80R/149/TP.11.
- (40) M.M. Gordon, F. Marti. Electric focusing in cyclotrons with unusual dees. Particle Accelerators 1980 (vol.11) pp. 161-172.
- (41) G. Dutto, M.K. Craddock. Focusing in rf accelerating gaps with asymmetrically curved electric equipotentials, Seventh Int. Conf. on Cycl. Zurich, Birkauser, Basel 1975, pp.271-274.

Note on axial motion perturbation.

Another perturbation comes from electric focusing as shown by M.M. Gordon and F. Marti⁽⁴⁰⁾. Their theory makes use of a treatment of rf cavity effects derived by G. Dutto et al⁽⁴¹⁾ which has some analogy with the representation given above in par. 2.4 provided, however, the derivation is there pushed to second order.

Close to $v_z = 1$ as is the case for the Indiana injector cyclotron a stop band is opened and instability develops ; the width of the stop band and the resulting amplitude growth during acceleration depend on the rf harmonic of operation through a factor which can be expressed in terms of A as introduced in (12) for the radial motion. For both axial and radial motion considerations A must be kept small.

In the case of spiral dees and spiral electric gaps, the axial focusing is further modified (as well as the radial focusing) ; the sign of the changes depends on the relative direction of the spiral with respect to the rotation of the particles.

" DISCUSSION "

M. REISER : I have a comment and a question. The comment is that one gets phase compression also due to time of flight effects in the RF gaps at low energies. The question is whether you studied the possibility of using the phase compression effect to counteract longitudinal space charge effects ?

P. LAPOSTOLLE : I agree with your comment ; this transit time effect comes into my mind in the Müller's voltage ramp compression method. As far as the effect of space charge, we did not study it, since we are far, for GANIL, from intensities where it plays a role. I think however that our scheme is exactly equivalent to a classical bunching system (buncher + drift) and space charge has for us the same kind of effect as it has there.

H. BLOSSER : Did you consider correcting for the injection magnet perturbation by putting in four magnets, one in every valley ?

P. LAPOSTOLLE : No, unfortunately two valleys are occupied by RF cavities.