

A WIDE-RANGE RADIO-FREQUENCY SYSTEM FOR AN 8 MeV INJECTOR CYCLOTRON

J.J. Kritzinger, R.E.F. Fenimore, G. Hardman, M.J. van Niekerk, A.H. Botha
National Accelerator Centre, CSIR, P.O. Box 72, FAURE, 7131, REPUBLIC OF SOUTH AFRICA

Summary

The main characteristics and components of the system, which operates in the frequency range 8 MHz to 26 MHz, are discussed. An amplitude stability of 0.001 and a phase stability of 0.1 degree have been obtained experimentally at a dee voltage of 60 kV.

1. Introduction

The k=8 cyclotron discussed here is the injector for the k=200 separated-sector cyclotron of the NAC. The injector operates with two 90 degree dees, each with its own resonator and power amplifier. A frequency range of 8.6 to 26 MHz was specified to obtain continuous energy coverage for both light and heavy ions. The maximum frequency of 26 MHz is dictated by the maximum proton energies in the injector and the separated-sector cyclotron respectively. In all parts of the radio-frequency system the aim has been to use wide-band circuits where possible, or else to use a single tuning component to cover the full frequency range. This objective was achieved in all cases.

2. Resonators

The main parameters of each system are listed in table 1. Two quarter-wave resonators are used as shown in figure 1.

TABLE 1 Resonator	
Frequency range	8.3 to 27 MHz
Dee voltage	60 kV peak
Power loss	18 kW at 26 MHz and 60 kV
Dee height	60 mm
Dee radius	600 mm
Inner cylinder	220 mm O.D and 5 000 mm long
Outer cylinder	700 mm I.D. and 4 700 mm long
Main tuning	Adjustable short-circuiting plate
Fine tuning	Adjustable capacitor plate
Power coupling	Capacitive with adjustment

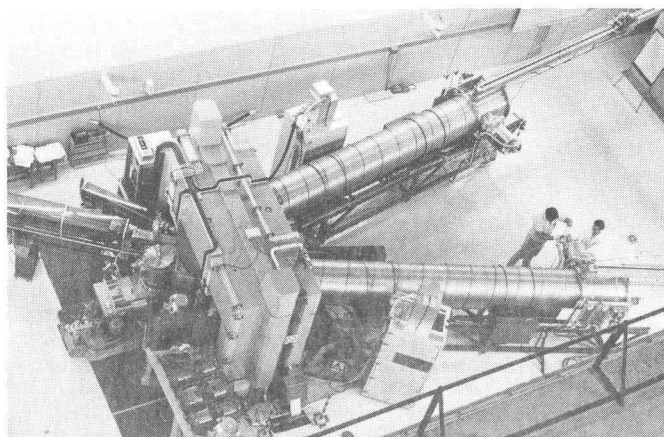

Fig.1 The injector cyclotron with the two resonators and the two power amplifiers in position

2.1 Dee and dee-stem

The 90° dees were manufactured from 2 mm thick copper plate and the cooling water pipes were attached with soft solder. Each top and bottom dee plate is screwed to the support for the dee with 50 screws to allow removal for maintenance of the parts mounted inside the dee-plates. The water connections are made with couplings using copper seals.

The dee-stem was first made in two parts from 2 mm copper plate to allow attachment of the cooling pipes. The parts were then welded together and subsequently welded to the support for the dee and to the inner cylinder. These parts can be seen in figure 2.

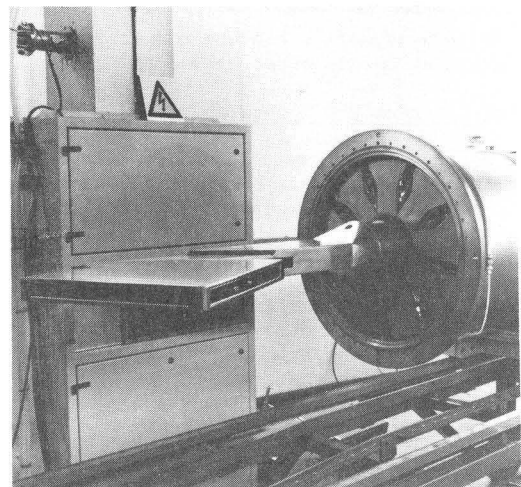

Fig. 2 In the centre is the 90°dee, dee-stem, inner cylinder, short-circuiting plate and outer cylinder. In the background is the power amplifier cabinet with its anode circuit on top.

2.2 Inner cylinder

The inner cylinder was electro-formed from copper to a wall thickness of 10 mm. Two spiral water-cooling channels, each of 4 by 15 mm cross-section, were created in the wall thickness. The cooling water is led to the far end of the inner cylinder by a pipe mounted on the inside of the inner cylinder and is returned to the near end by the two spiral channels. The accuracy of the outside of the inner cylinder is better than 0.5 mm. The surface roughness is less than 2 microns to ensure minimum heating by the rf current. Both ends of the inner cylinder are supported on a 5200 mm long tapered stainless steel beam fitted inside the cylinder and cantilevered from the end of the resonator. The weight of the dee, the dee-stem and half of the inner cylinder is carried by the unsupported end of the stainless steel beam. This weight causes the end of the beam to deflect downwards by 30 mm. A screw is provided to adjust the inner cylinder into a horizontal position. The stiffness of the inner cylinder and beam assembly is such that a 1 kg force deflects the dee by 0.5 mm vertically or 1.0 mm horizontally.

2.3 End support structure

This stainless steel part forms the connection between the inner cylinder support beam and the outer cylinder. It is shown in figure 3. The inner cylinder is adjusted concentric with the outer cylinder to better than 0.5 mm by means of the adjustment facilities provided on the support structure. After evacuation it is still possible to adjust the dee vertically by means of the external lever system. A stainless steel bellows allows this relative movement between inner and outer cylinders. A 400 mm flange on the side of this structure permits evacuation of the resonator from this end.

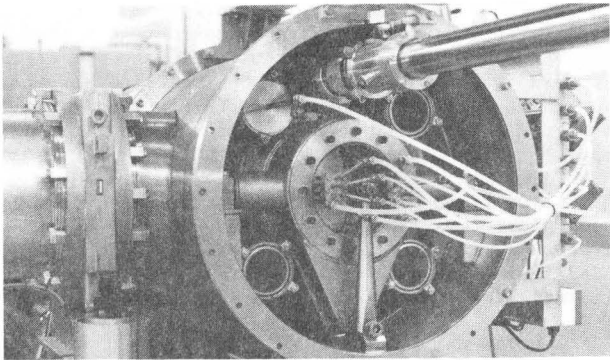

Fig. 3 The end support structure connecting the inner cylinder to the outer cylinder.

2.4 Outer cylinder and Resonator support

The outer cylinder was also electro-formed from copper. The wall thickness is 15 mm and a cooling pipe is soft soldered to the outside. The inside surface, carrying the rf current, was honed to give a surface roughness of less than 3 microns and the dimensional errors are less than 0.5 mm. The outer cylinder, end support structure, inner cylinder and the dee form a single unit which is mounted on two trolleys running on rails on the supporting stand. Additional rails give horizontal guidance so that the dee can be removed from the centre of the cyclotron without colliding with the magnet vacuum chamber.

2.5 Tapered section and pole liners

The tapered section forms the electrical and vacuum connection between the outer cylinder and the magnet vacuum chamber. It is bolted directly to the vacuum chamber but the connection to the outer cylinder is via a stainless steel bellows for the vacuum connection and via flexible contact strips for the electrical connection. This joint forms a pivot point which is 1200 mm from the cyclotron centre and therefore allows accurate positioning of the dee in the cyclotron without disturbing the concentricity between inner and outer cylinder. 5 mm of linear adjustment along the centre line of the cylinders is also possible.

The dummy dees are attached to the pole liners which in turn are attached to the magnet poles. The upper yoke and pole can be raised for maintenance and the electrical connection between the pole liners and the copper parts in the magnet vacuum chamber is therefore made by sliding contact fingers.

2.6 Short-circuiting plate

The main characteristics of the short-circuiting plates are listed in table 2. The short-circuiting plate is required to make electrical contact between the inner and outer cylinder and its position is the main variable controlling the operating frequency. It is shown in figure 2 and can be installed or removed when

close to the dee without detaching the inner cylinder from the outer cylinder. It consists of 9 sectors which are mounted on a support ring that can be split in half. One sector, each with its own cooling circuit, is shown in figure 4. Each contact finger is 14 mm wide, 35 mm long, 0.25 mm thick and has two 6 mm diameter silver contact heads mounted on one end. The other end is soft soldered to the 3 mm thick intermediate copper plate. The contact pressure is generated by feeding compressed air to a bellows assembly. The pressure is applied to each finger through a transfer system which presses centrally between each pair of contacts by means of guided pushers. Coil springs limit the maximum pressure and distribute it evenly to each finger.

Number of sectors	9
Range of travel	4400 mm
Current density on inner	20 amp/cm r.m.s. maximum
Power dissipation	2 kW maximum
Range of contact fingers	10 mm

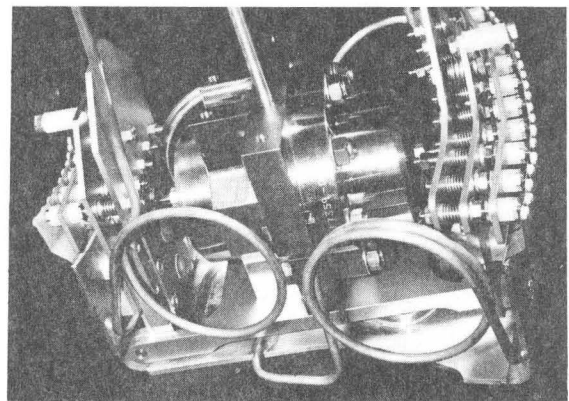

Fig. 4 One sector of the short-circuiting plate.

The contact fingers are manufactured from special dispersion-strengthened copper. This material has thermal and electrical conductivities close to that of pure copper while the mechanical properties are similar to that of unhardened copper-beryllium, thus making it an ideal material for contact fingers. Our tests have shown that the mechanical properties are adequate for the requirements of the short-circuiting plate and that the temperature rise is only one eighth of that with copper-beryllium for identical current conditions. A hinge system is required to obtain a 10 mm range of movement for the contact fingers. Dispersion-strengthened copper, 0.25 mm thick, was used for the current-conducting part of the hinge. The 3 mm thick intermediate copper plate joining the contact fingers to the hinge is water cooled by 5 mm O.D. copper tubing soldered to the plate. The interconnecting tubing is coiled to allow the required movement. A pressure differential of 1.5 bar is required for the bellows to generate sufficient contact pressure for reliable operation. To change frequency, this differential pressure is reduced to less than 0.05 bar to release all contact fingers, before moving the short-circuiting plate.

The short-circuiting plate assembly is supported and guided by four wheels running on the bottom inside surface of the outer cylinder. Rotation of the short-circuiting plate is prevented by two additional wheels rolling on a guide strip mounted along the bottom of the outer cylinder. The short-circuiting plate is positioned by means of a 5500 mm long pusher tube (75 mm O.D.) which slides through a differential vacuum seal mounted on the end support structure. The

outer end of the pusher tube is attached to a trolley running on a support and guide beam. This trolley is driven by a DC motor and gearbox operating through a sprocket running in a pretensioned chain, mounted on top of the beam. The cooling water and compressed air for the short-circuiting plate are taken through the inside of the pusher tube to avoid long flexible pipes in the vacuum.

2.7 Tuning capacitor

The tuning capacitor is shown in figure 5. It is mounted on a plate bolted to the side of the magnet vacuum chamber. The effective area is 80 by 300 mm and the distance from the back of the dee can be adjusted to be between 15 and 60 mm. This gives a frequency change of at least 1% over the frequency range. The movement is controlled by a stepping motor driving a lead-screw. A very flexible bellows provide vacuum sealing. An unique feature is the contact system which consists of a copper roller held between two sets of contact fingers, the one set mounted on the movable capacitor plate and the other set stationary. It is used at the top and the bottom of the capacitor. In operation this has proved very successful provided the roller has the correct diameter to maintain the two sets of contact fingers parallel to each other.

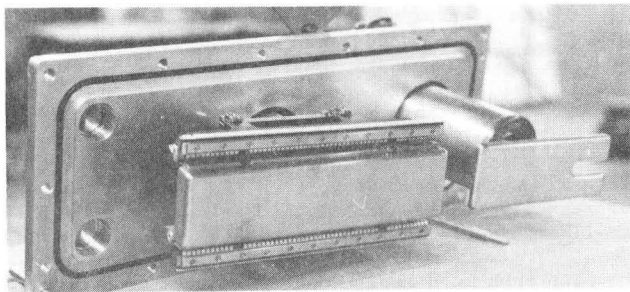

Fig. 5 On the left is the tuning capacitor and on the right the adjustable coupling capacitor.

2.8 Coupling capacitor

The coupling capacitor is mounted on the same plate as the tuning capacitor. It is also shown in figure 5. Experiments on the full-scale model of the resonator showed that there is an optimum location for the coupling capacitor, resulting in the minimum amount of adjustment required (25 mm) over the frequency range. The coupling capacitor is adjusted to obtain the optimum power transfer from the power amplifier to the resonator. The effective area of the capacitor plate is

80 by 200 mm and the distance between it and the dee stem can be adjusted to be between 45 and 70 mm.

The main mechanism of the coupling capacitor was manufactured by a firm producing vacuum variable capacitors. Standard insulators and copper bellows are used. The drive for positioning the capacitor is taken through the centre of the coaxial input connection by means of a rod made from insulating material. A stepping motor positions the capacitor and the position is measured by an absolute shaft encoder. Air cooling is required for the coupling and tuning capacitors.

3. Power amplifiers

The two power amplifiers were developed and constructed at the NAC. The main characteristics are listed in table 3.

Frequency range	8.2 to 27 MHz
Maximum power	25 kW between 12 and 27 MHz
Anode tuning	Vacuum variable capacitor 25-1000 pF
Load tuning	Preset by tap-off position on anode circuit
Input tuning	Variable inductance of pi-circuit
Amplifier tube	25 kW water-cooled tetrode
Driver amplifier	500 W broadband solid state amplifier

The main objective was to build a reliable power amplifier with the minimum number of variable controls to cover the required frequency range. The main circuit components are shown in figure 6. The anode circuit is a fixed length (1000 mm) coaxial quarter-wave circuit, tuned by a 25 - 1000 pF vacuum variable capacitor. The impedance conversion between anode and load can be altered by changing the position where the inner conductor of the 50 ohm output cable is joined to the inner conductor of the anode circuit. Once this position has been optimised the entire frequency range can be covered without further changes. The anode voltage is applied through the centre of the inner conductor of the anode circuit. The pipes carrying the cooling water to the anode run in the space between the inner and outer parts of the anode circuit. The output of the amplifier is connected to the coupling capacitor on the resonator by a 3 m length of 40 mm O.D. 50 ohm coaxial cable. Below 12 MHz the power output is gradually reduced below the level of 25 kW owing to the current limit of the anode tuning capacitor. This does not present any problems since the power required to generate the maximum dee voltage of 60 kV decreases gradually from 18 kW at 26 MHz to 5 kW at 8.6 MHz. At the lower frequencies at least twice the required power is available.

The tetrode input uses a tuned pi-circuit to overcome the loading effect of the tube input capacitance. To reduce the power requirements of the standard wide-band driver amplifier, a transmission-line transformer is used at the input to the pi-circuit to increase the impedance level from 50 to 200 ohm. This is also the impedance seen by the input grid of the tetrode. A standard 1 kW 50 ohm load resistor is connected through a second transmission-line transformer to the output of the pi-circuit to provide the correct termination. The input capacitance of the tetrode forms the output capacitance of the pi-circuit. A capacitor of equal value is used at the input of the pi-circuit. A single variable inductor provides tuning over the full frequency range. Standard power supplies are used. The switch-on sequence and protection is controlled by a system constructed at the NAC. This system also allows remote operation from the control computers via CAMAC and relays the amplifier conditions back to the computers.

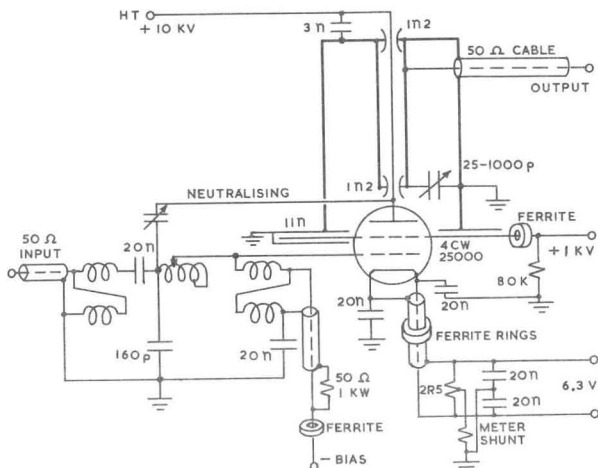

Fig. 6 The circuit of the 25 kW power amplifier showing the main components.

4. Low-level control

The various components of the low level control system for one resonator and their interconnections are shown in figure 7. The main characteristics are listed in table 4.

Amplitude stability	Variation less than 0.001
Phase stability	Variation less than 0.1 degree.
Auto-tune module	Keeps resonator tuned with less than 2 degree phase error.
Signal distribution	32 outputs with less than 0.3 degree phase difference.
Coarse phase shifter	360 degrees over frequency range in 256 steps.
Vernier phase shifter	Minimum increment 0.05 degree with 256 steps.
Phase detector	0.1 degree resolution and stability at constant level.
Phase controller	Double modulated system using phase modulated 55 MHz carrier.
Amplitude controller	16-bit resolution for dee-voltage stabilisation plus adjustable power limit with automatic change-over diode switch.
Control	By mini and micro-computer via CAMAC and special buffer units.

or if the power is removed. The phase between the dee-voltage probe and a special probe on the power feed point to the coupling capacitor indicates the state of tune of the resonator and is used by the auto-tune phase detector to keep the resonator tuned.

4.2 Phase shifters

The coarse phase shifter (BDL in figure 7) use PIN diodes to switch 8 delay cables in or out of circuit. The delays of the cables are arranged in a binary manner enabling 256 delay settings to be obtained. The delay setting is retained by a built-in 8-bit latch and switching is so rapid that phase changes can be made while feeding power to the resonator.

Varactor diodes are used as the phase-changing element of the vernier phase shifters. The diodes form part of a lumped delay line. All phase-critical components are mounted in an oven stabilised to $45 \pm 1^\circ\text{C}$.

5. Operational experience

The first time power is applied to a resonator, up to 4 hours may be required for conditioning. After this initial conditioning, operation at normal voltage can be achieved immediately by switching the power on with a fast rate of rise to a level of between 2 and 5 kW. This was found to be possible even after the resonator had been open to the atmosphere for a period of two weeks. Stable voltage operation was obtained between 10 and 60 kV. When both resonators are driven correctly the two dee voltages are equal and in phase. Operation at the lowest frequency (when the short-circuiting plate gives the least support to the inner cylinder) was surprisingly stable and no voltage-induced mechanical oscillation could be observed with 60 kV dee voltage.

The open-loop amplitude ripple is approximately 0.5% and most of this is due to the voltage ripple of the anode power supply. The short term open-loop phase stability is better than 0.1 degree. A slow phase change, caused by temperature changes in the resonator with variation in power level, was observed. Operation is very stable even without phase and amplitude stabilisation. No serious mechanical vibration of the resonator was observed, except when a cryopump was operated at the end of the resonator. A cryopump is not essential since a turbo-molecular pump satisfies the vacuum requirements.

The dee-voltage probes were calibrated using a silicon X-ray detector to observe the X-rays, related to the dee voltage, through a plastic window. An accuracy of 1 kV was achieved. This calibration is confirmed by the beam orbit patterns recorded when the cyclotron was tested with internal beam. Operation of all systems during these tests has been very satisfactory. Some spark-over was experienced between the ion source and the puller electrode on the dee at 26 MHz but this will be avoided by removing sharp edges.

Acknowledgements

Mr H.A. Smit was responsible for most of the mechanical design of the resonators and Mr. A. Müller for the design of the short-circuiting plates and their positioning mechanism. The NAC workshop manufactured many of the smaller parts. Mr A. Kiefer and Mr. J.J. Kotze assembled the resonators.

Apart from the authors Mr R.D. Jones and Mr. J.W. Carstens developed and constructed the power amplifiers and their control, while Mr. P.J. Kriel, Mr. Z. Hajek and Mr. J.W. Carstens contributed to the low-level control.

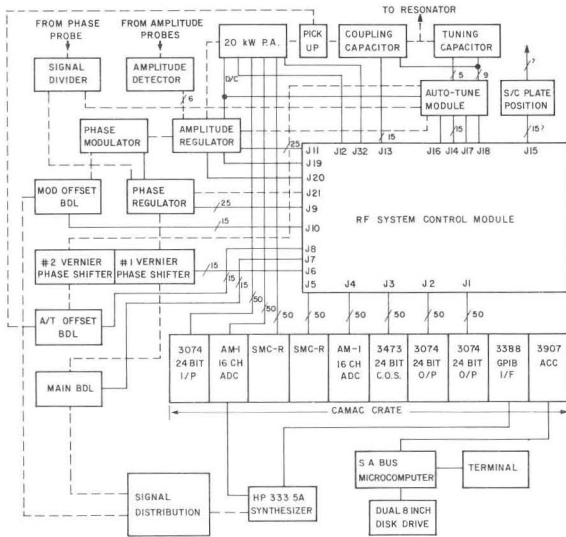

Fig. 7 The various components of one resonator control system and their interconnections.

All parts of the low-level control system were developed and constructed at the NAC except the frequency synthesiser and CAMAC units. Some of the special features of this equipment are described below.

4.1 Auto-tune module

This module provides control of the speed and direction of the stepping motor on the tuning capacitor. An absolute position encoder allows the position of the capacitor to be preset for start up. A sensitive amplitude detector monitors the dee voltage. When this level is sufficient for the auto-tune phase detector to function correctly the module switches automatically to analogue control loop operation. A dead-band region of 1.5 degree is used to prevent continuous hunting of the system. The module stops the tuning capacitor in the last operating position when the resonator sparks over