

THE INDIANA UNIVERSITY CYCLOTRON FACILITY ELECTRON COOLING SYSTEM*

Otto C. Dermois†, Timothy J.P. Ellison, and D.L. Friesel
 Indiana University Cyclotron Facility, Bloomington, Indiana 47405 USA

Summary

The overall design of the electron beam cooling system for the Indiana University Cooler-Storage ring is described and the desired properties of the variable energy and intensity, low temperature electron beam are presented. The general layout of the electron beam system is described and the designs of the gun, collector, drift and clearing electrode, vacuum, and magnetic guide field systems are discussed. The paper concludes with a report on the present status of the electron beam system.

Introduction

A six-sided storage ring^{1,2} with electron cooling and synchrotron acceleration is now under construction at Indiana University. It is designed to accept, accelerate and cool the light ion beams (H, D, He, Li) from the existing IUCF, K=200, separated sector cyclotron³ and to provide high quality beams ($\Delta p/p=10^{-5}$) for intermediate energy nuclear research. The Cooler ring has an 87m circumference, a field limit of 3.6 T-m, an operating range from 20 to 500 q²/A MeV, and several operating modes, both with and without electron cooling, to enhance its effectiveness as a research instrument.^{4,5} This versatility and the high quality ion beam properties desired impose broad and stringent demands on the properties of the electron beam cooling system.

The variety of injected ions and broad operating range of the Cooler require an electron beam variable in energy from 7 to 275 keV. Transverse electron beam temperatures of less than a few tenths of an electron volt at intensities from 0 to 4 amperes are needed over the full operating range to achieve rapid cooling and maximum phase space density of the ion beam, particularly for the Cooler operating mode using thin ($<10^{-7}$ g/cm²) internal targets. The design goals for the electron beam cooling system are summarized in Table I, and discussed in more detail below.

TABLE I. IUCF Electron Beam System Design Parameters.

Electron Beam Energy Range.....	7-275 keV
Electron Beam Intensity Range.....	0-4 Amperes
Electron Beam Diameter.....	2.54 cm
Electron Gun Perveance	0.68×10^{-6} perv
Transverse Electron Beam Temperature ...	<0.1 eV
Electron Gun Accelerator Column Length..	62.3 cm
Max. Column Electric Field Gradient.....	11.3 kV/cm
Max. Solenoidal Magnetic Field	1.5 kG
Max. Radial Magnetic Field Component ...	<1 part in 10^3
Effective Cooling Region Length	270 cm
Collector Efficiency	99.99 %

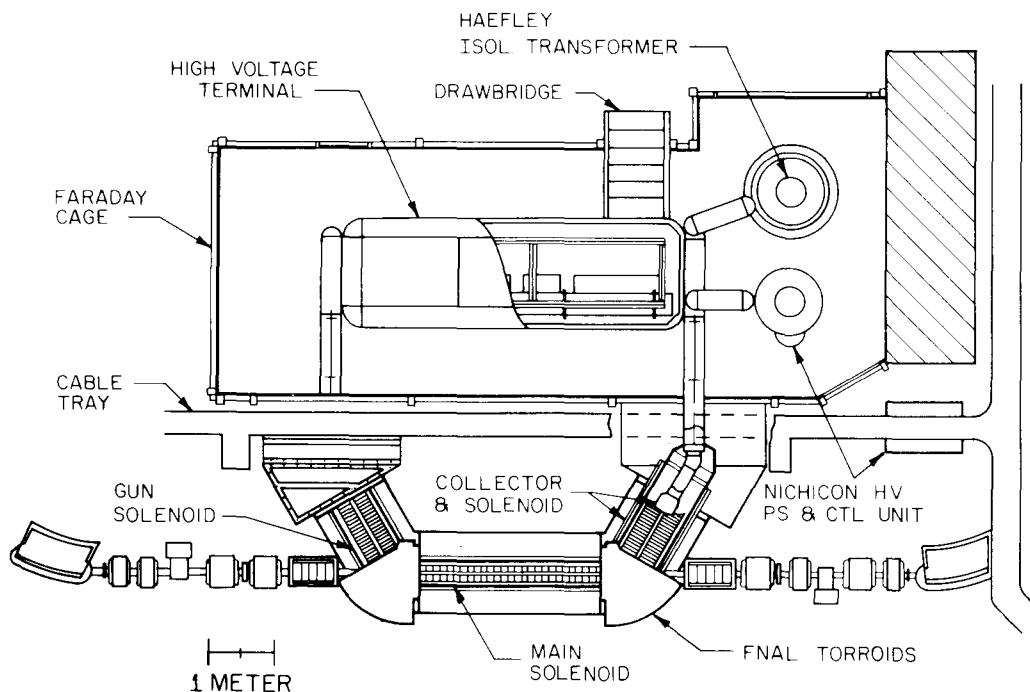

Figure 1. Layout of IUCF electron beam system.

*Research supported by the National Science Foundation under grant NSF PHY 82-11347.

†Presently on leave from the Kernphysisch Versneller Institute; Universiteits Complex paddepoel; 9747 AA Groningen; NETHERLANDS

The Electron Beam System

General Layout and Magnetic Guide Field

The general layout of the IUCF electron beam cooling system is shown in Fig. 1, and differs from most previously reported systems in that the electron gun and collector systems lie in the horizontal plane. The electron gun, collector, and associated acceleration and deceleration columns are immersed in solenoidal magnetic guide fields produced by 135 cm long, 58 cm diameter gun and collector solenoids. The electron beam is directed into the stored ion beam path of the Cooler ring and back out into the collector by steering dipoles located in two 60° toroids, which were originally used in the Fermilab electron beam cooling experiment⁶ and modified for use in our system. The 270 cm long, 25 cm diameter main solenoid, in which the ion beam cooling occurs, connects the gun and collector solenoids via the toroids and completes the magnetic guide field system for the electron beam. Vertical and horizontal steerers and compensating solenoids are located in the cooler ring at the entrance and exit of the electron beam system to counter the effects of the toroid and main cooling solenoid on the circulating ion beam. The solenoids may be safely operated at a field of 2.0 kG, although initial operation will be limited to 1.5 kG by the power supply. Radial field components produced by imperfections in the solenoids and at the solenoid-toroid interfaces along the electron beam path will be reduced to less than 0.1% of the axial field by the addition and adjustment of correction coils dictated by magnetic field mapping studies. The design of the magnetic guide field and mapping systems, and the projected magnetic field properties are discussed in more detail in another paper published in these proceedings.⁷

The entire electron gun, collector and magnetic guide field systems are mounted on a single, large reinforced concrete block, which is placed on rails so it can be moved out of the Cooler ring for field mapping and off line beam testing, modifications or repairs, as shown in Fig. 2. The rectangular extension between the Faraday cage and the gun and collector solenoids may be removed to permit this motion. The gun and collector solenoids will also be mounted on a precision rail system so that they can be moved back from the toroids for easy access to the gun and collector systems.

High Voltage System

The floor plan for the high voltage system is also shown in Fig. 1. The 300 kV high voltage terminal has a useful area of 8.4 m² and contains the power and water cooling distribution systems for the electron gun and collector. The terminal shell is constructed from 304 stainless steel and is surrounded by a galvanized sheetmetal and aluminum walled Faraday cage with a minimum separation distance of 0.91 m to minimize corona. The Haefely voltage dividers, water cooling circuit, 300 kV Nichicon high voltage power supply and 75 kVA, 375 kV isolation transformer will all be mounted on a common copper sheet which will be insulated from the Faraday cage floor. The currents from the gun and collector gradient resistor chains, from the floating conductor covering the inside of the gun and collector solenoid mandrils, and the Faraday cage itself will all be returned to this copper sheet through separate 100 ohm metering resistors with isolation amplifiers connected across them. Recent tests with the Haefely 100:1 a.c., 300 kV dc voltage divider have shown that we can measure ripple voltage amplitudes as low as 0.1 V.

Two weeks after this conference, representatives from IUCF will visit the Nichicon Capacitor Ltd. factory in Kyoto, Japan to witness the rigorous testing of the main 300 kV, 15 mA power supply. Nichicon has agreed to a voltage ripple specification of $\Delta V/V = 2.5 \times 10^{-5}$ at 5 mA, and will work to achieve better than 1×10^{-5} when the supply is installed at IUCF. A more detailed description of the high voltage system design was previously reported.⁸

Electron Gun System

The design of the electron gun and acceleration system is similar to the high perveance 750 keV system developed at Fermilab.⁹ A flat, 2.54 cm diameter, dispenser-type cathode is mounted in a cylindrically symmetric pierce geometry on the axis of the gun solenoid with an anode and two guard electrodes. The gun-anode spacing is adjusted to give a perveance of 0.68 microperv and an adiabatic acceleration of beam into the acceleration column, which consists of two 18 element, NEC, high gradient accelerator tubes. The entire assembly is cantilevered from the toroid-solenoid interface plate and held under compression by three Vespel rods. The acceleration voltage and other services needed for the gun assembly are brought from the terminal to the end of the gun solenoid via a 31 cm diameter, variable length aluminum pipe. The end of the gun solenoid is capped with a lucite seal which supports the pipe and permits the area surrounding the gun system to be maintained at 1 atmosphere of SF₆ to reduce corona and breakdown.

Computer modeling studies of the electron beam properties from this structure, using the SLAC electron gun design code EGUN¹⁰, were previously reported in detail.¹¹ Edge transverse electron beam temperatures of less than 0.1 eV at magnetic fields greater than 1.3 kG are predicted over the desired energy range without the use of resonant focusing for ideal solenoidal magnetic fields. Inhomogeneities in the confining field can cause transverse heating of the electron beam, and therefore the field imperfections at the toroid-solenoid interface may make the use of resonant focusing necessary. Initial operation of the electron beam system will be made without resonant focusing, but provisions are being made to add this capability if it is needed.

Collector System

The IUCF electron cooling system collector is modeled after the successful Fermilab design,¹² which was able to collect 99.99% of the electron beam at low energies (T < 50 keV) and 99.94% at higher energies (T = 114 keV). The Fermilab collector geometry was scaled down by a factor of two in diameter to match the IUCF electron beam diameter of 2.54 cm. The average collector diameter and depth are 10 cm and 14 cm respectively. There are 20 square cooling channels each with a cross section of 0.1 cm². A high water flow rate, 4 l/s, was chosen to increase the value of the film coefficient and to keep the outer surface of the collector below 100°C with 50 kW of power flowing into the copper collector, which has a surface area of 64 cm². The water temperature rise is expected to be negligible.

In addition to the change in size, a number of other changes were made to improve the collection efficiencies of the IUCF collector beyond those obtained at FNAL. These are:

1. The collector anode, which acts as a suppressor for the electrons backscattered from the collector, is split into two sections, each powered by an independent source.

2. A thin (<1 micron) layer of carbon will be deposited on the inner surface of the collector to suppress backscattering. In principle this will reduce the number of high energy backscattered electrons by a factor of about three,¹³ and increase the collection efficiency accordingly.

3. The collector will be operated at about 10 kV positive relative to the cathode, which is much higher than used in previous electron cooling system designs. The number of high energy backscattered electrons per incident electron, and their energy distribution (dn/dk , where k is the ratio of the backscattered and the incident electron energies), are almost independent of the incident electron energy.¹³ Therefore, the number of backscattered electrons with enough energy to escape through the collector anode is proportional to the collector anode voltage divided by the collector voltage. The increased collector voltage is expected to increase efficiencies by another factor of 2.

4. There are two very strong trim solenoids in the collector region providing independent control of the magnetic field at the collector and collector anode. The magnetic field at the collector can be varied by up to 10% of the nominal magnetic field while keeping the field at the collector anode constant. The clearance of the beam through the collector anode, which is the most severe aperture restriction in the cooling system, can also be adjusted without altering the field in the collector significantly.

Correction Dipole System

Horizontal and vertical correction dipoles are located in the gun, collector, and main solenoids which can move the electron beam by about ± 2 cm. Using the dipoles in the gun solenoid and a resonant longitudinal Schottky pick-up, it will be possible to infer the amount of space charge neutralization by correlating the ion beam revolution frequency with the electron beam position in the electron cooling region. The dipoles in the main solenoid are used to align the electron and proton beams and to create artificially large transverse temperatures. By determining the minimum angle between the beams which degrades the cooling efficiency, the transverse temperature of the electron beam can be estimated. The dipoles in the collector will then be used to steer the electron beam through the collector anode aperture.

Vacuum System

The main pumps used to reach a pressure of about 10^{-9} mb are nonevaporable getter modules of the type WP 1250/ST707. Four of the modules are located in each toroid vacuum chamber and provide a pumping speed of about 1000 ℓ/s for CO and 2500 ℓ/s for H₂. To get some pumping speed for the noble gases, a 30 ℓ/s triode ion pump is attached to the vacuum chamber of each toroid. Hence, the system is self supporting and can be used for off line testing. Initial pumpdowns will be done with a portable turbopump unit. The whole vacuum system, including the accelerator columns, can be baked at about 250°C.

Assuming an outgassing rate of 10^{-11} mb ℓ/sec cm² for all parts, we expect a pressure of about 10^{-9} mb in the center part of the solenoid vacuum chamber, without beam loading. The outgassing rate of many parts will be lower due to a one time pre-bake at 950°C. At present, there are no additional pumps planned for the gun and collector regions.

Drift Electrode System

The drift electrode system is a series of 11 electrically isolated electrodes inside the electron cooling system vacuum chamber, which insure that the electron beam never sees the grounded vacuum chamber wall at any location. This system has three important functions:

1. It removes the electrons and positive ions caused by collisions between the electron beam and the residual gas atoms in the vacuum system. The electrode potentials monotonically become more negative as one moves in the direction of the collector. Thus all the ions are immediately accelerated to the collector. The electrons, however, are trapped transversely by the longitudinal magnetic field, and longitudinally by the negative potentials of the gun and collector. Split drift electrodes are used to provide a transverse ExB drift. Depending upon the polarity of the electric field, the electrons will drift either to a resistive plate connecting the split electrodes, or to a beam stop which can be used to measure the electron current.

2. Two drift electrodes at the beginning and end of the main cooling solenoid also function as the position electrodes. The gun anode power supply has a few volts of ripple at harmonics of 30 kHz, providing hundreds of micro amperes of modulated beam current during operation. This is more than adequate for good position measurements using electronics recently developed to make accurate position measurements of beams in excess of about 10 enA.¹⁴ However, the ripple on the power supplies which provide DC bias for these electrodes will be many orders of magnitude larger than the mV level signals induced by the electron beam. For this reason, a separate oscillator, operating far away from the supply switching frequency, will be capacitively coupled to the gun anode electrode.

3. The drift electrode inside the cooling solenoid will be powered by a 1000 V bipolar op-amp power supply with kHz frequency response. This is sufficient voltage to move any ion beam across the momentum aperture of the storage ring. This supply will be used for putting ramps on the electron beam energy and to perform experiments, such as measuring the longitudinal drag force of the electron beam. In addition, an isolation amplifier with 100 kHz frequency response will float at the potential of the 1000 V supply and directly power the electrode. This fast amplifier will be used to apply the cathode ripple voltage to the drift electrode.

Construction Status

At present, all the major components for assembling the system are in house or due for delivery by January or February of 1987. The Faraday cage and concrete base for the solenoids are constructed and in their final location. The high voltage terminal will be delivered in late October 1986, and will be installed upon delivery. The modifications to the Fermilab toroids are complete and the solenoids are expected to be delivered by January 1987. The mounting of the toroids and the solenoid support structures on the concrete base, and the installation of the isolation transformer and other power supplies will be accomplished in November and the electron system guide field will be mapped in its final resting place upon delivery of the solenoids in January. After the mapping and field corrections are complete, the gun, collector and acceleration systems will be installed and tested. Operation of the complete electron system is expected toward the end of 1987.

References

1. R.E. Pollock, IEEE Trans. Nucl. Sci., NS-30 (1983) 2056.
2. H.O. Meyer, Indiana Cooler Users Guide, IUCF Internal Report (1983).
3. R.E. Pollock, IEEE Trans. Nucl. Sci., NS-26 (1979) 1965.
4. R.E. Pollock, Comments Nucl. Part. Phys. 12 (1983) 73.
5. H.O. Meyer, Proc. Uppsala Workshop on the Physics Program at CELSIUS, (November 1983).
6. T. Ellison, W. Kells, V. Kerner, F. Mills, R. Peters, T. Rathbun, D. Young, and P.M. McIntyre, IEEE Trans. Nucl. Sci. NS-30, No. 4 (1983) 2636
7. Otto C. Dermois, "The Design of Homogeneous Field Solenoids for the IUCF Cooler Section", these proceedings.
8. T. Bertuccio, B. Brown, G. Donica, T. Ellison, D. Friesel, J. Hicks, and R.E. Pollock, IEEE Trans. Nucl. Sci. NS-30, No. 5 (1985) 3128.
9. L. Oleksiuk, Fermi National Accelerator Laboratory Report, TM-1038, 8035.000 (April 1981).
10. W.B. Hermannsfeldt, SLAC Report-226, Stanford Linear Accelerator Center (1979).
11. D.L. Friesel, T. Ellison, and W.P. Jones, IEEE Trans. Nucl. Sci. NS-32, No. 5 (1985) 2421.
12. W. Kells, P. McIntyre, L. Oleksiuk, N. Dikánský, I. Meshkov, V. Parkhomchuk, FNAL TM-918 (1979).
13. Ernst J. Sternglass, Phys. Rev. Vol. 95, No. 2, (1954) 345-358.
14. Timothy J.P. Ellison, C.M. Fox, S.W. Koch, and Lui Rui, "Diagnostics for Measuring the Position and Phase of 15 enA Beams from the IUCF Cyclotrons", these proceedings.

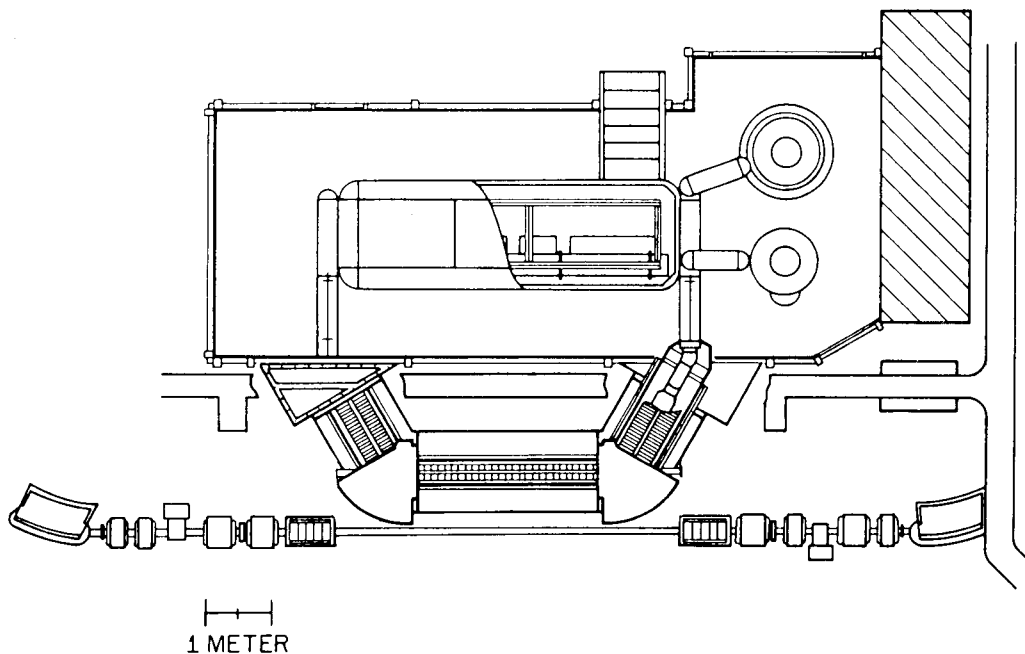

Figure 2. IUCF Electron System in off line position.