

DESIGN AND MEASUREMENT OF THE LANZHOU 1.7m SFC MAGNETIC FIELD

Ma Zhongren
 Institute of Modern Physics, Academia Sinica
 57 Nanchang Road, Lanzhou, China

Summary

A brief description of the magnet system and field mapping for the Lanzhou 1.7m SFC are given.

The new magnet system of Lanzhou 1.7m SFC was set up in 1984 and the field measurement and field trimming had been completed in 1985.

Figure 1 shows the Cross-sectional view of the pole.

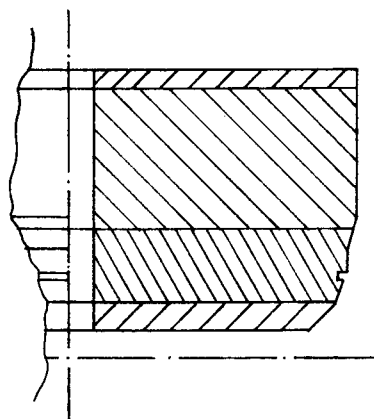

Figure 1: The cross-sectional view of the pole.

The field range should be from 8 kgauss to 16 kgauss with minimum saturation effects. As the diameter at pole base is only 200 cm and the pole tip diameter is 170cm, there

are only 15cm left for the margin of the pole piece to simulate Rogowski profile.

The sectors are designed to meet the isochronism requirement with least amount of current required for trimming coils. For the sake of convenience in machining, the spiral boundaries of the sectors are simulated by a combination of circular arcs. "Rose shims" are mounted on the edge of the pole tip.

Main Technical Parameters of Magnet

Energy constant	69
Magnet pole tip diameter	170cm
Magnet pole base diameter	200cm
Extraction radius	75cm
Number of sectors	3 pairs
Max. spiral angle	33 degree
Gap between hills	19cm
Gap between valleys	31.6cm
Average magnetic field at extraction radius	8.0-16.0 kgauss

The 12 pairs of circular trimming coils are made from mineral isolated cable, they are mounted coaxially with the geometrical center of the machine. The harmonic coils installed in the valleys of the magnet to compensate the first harmonic of the main field. They are arranged as four groups and are supplied by special D.C. power supplies adjustable with the so-called "sinusoidal voltage dividers", so that the first harmonic can be compensated by adjusting the amplitude and "phase" of the currents without affecting the average magnetic field.

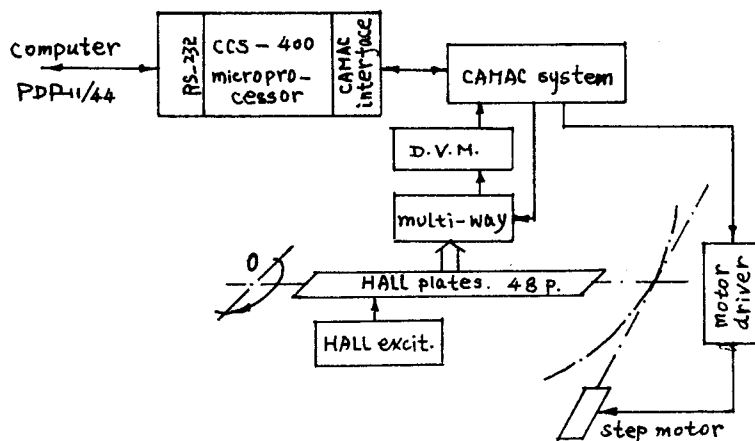

Figure 2: The block schematic of the CAMAC system

The magnetic field was measured by a calibrated Hall element system, in which 48 pieces of Hall plates are set in four separate cases to keep constant temperature. The Hall voltage was read by a 7.5 bit digital voltmeter and the data were fed to a microprocessor CCS-400 with a CAMAC system. The Hall elements were mounted in the medium plane of the magnet on a brass turn-table, which was driven by the CAMAC system too. The analysis of the data was done off-line on a little computer PDP-11/44. The block schematic of the system is shown in Fig. 2.

Figure 3 shows the measured field map at exciting current of 800a, Fig.4 shows the amplitude distribution of the first harmonic component of the magnetic field. The amplitudes at center region, main acceleration segment and pole fringe are 4 gauss, 3 gauss and 6 gauss respectively. It is obvious that the tolerance for six sectors are satisfactory. In practice, three sector pairs are set symmetrically around the magnet center with tolerance about 10 microns, the homogeneity of magnet gap is less than 50 microns.

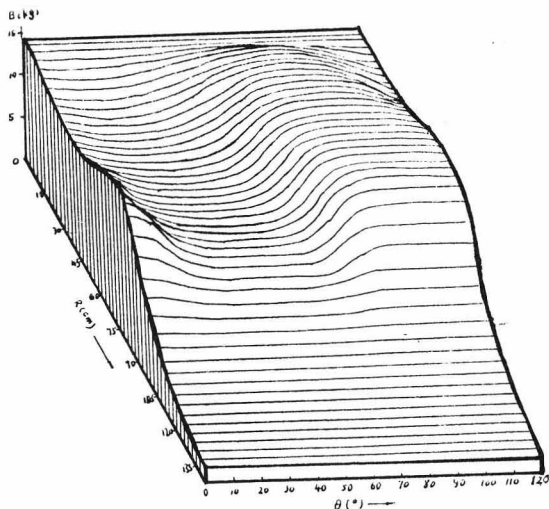

Figure 3: The field map (at 800 a).

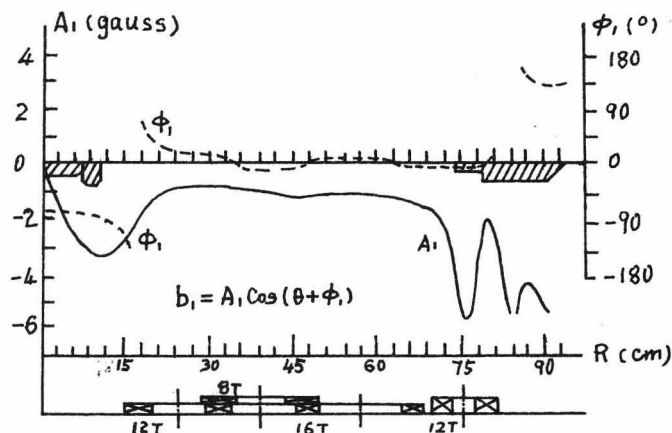

Figure 4: The distribution of the first harmonic.

The isochronous field was calculated with a computer DJS-6 by orbit integration method, and the optimum currents of the main coil and the twelve trimming coils were got by the method of least squares. The differences between isochronous field and trimmed field at different radii are less than 4 gauss. (Fig.5).

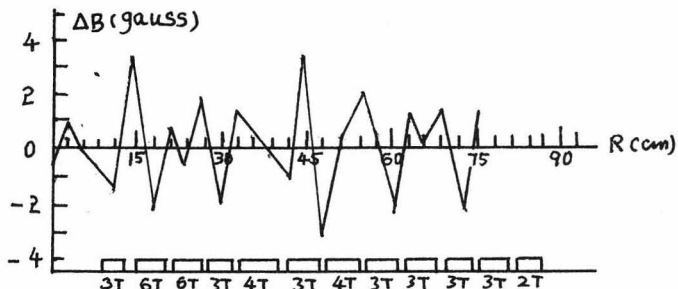

Figure 5: The trim error of the magnetic field.

Reference

- (1) Wei Baowen, Present Status of Lanzhou Heavy Ion Research Facility, Proc. Japan-China Joint Symp. on Acc. for Nucl. Sci. and their Apil., 1980
- (2) Zhang Shoujin, Progress of the 1.7m SFC, This Conf.