

RADIO FREQUENCY SYSTEM OF THE RIKEN RING CYCLOTRON

T. Fujisawa, K. Ogiwara, S. Kohara, Y. Oikawa, I. Yokoyama,
M. Nagase, I. Takeshita, Y. Chiba and Y. Kumata⁺
The Institute of Physical and Chemical Research, Wako-Shi Saitama 351, Japan

The radio-frequency(RF) system of the RIKEN ring cyclotron(K=540) is required to work in a frequency range of 20 to 45 MHz and to generate the maximum acceleration voltage 250 kV. A new movable box type variable frequency resonator was designed for that purpose. The final amplifier is capable to deliver 300kW. The resonators and the amplifiers have been installed at RIKEN and the performances are studied. The result shows the movable box type resonator and the power amplifier system satisfy the design aim.

Introduction

General features of the RIKEN ring cyclotron have been already described¹. In Table 1, the basic parameters of the RF system are summarized.

Table 1 Basic parameters of the RF system.

Number of resonators	2
RF frequency	20 ~ 45 MHz
Harmonic numbers	5,9,10,11
Maximum dee voltage(RF peak)	
at injection radius	100 kV
at extraction radius	400 kV
Voltage stability	$\pm 10^{-4}$
Phase stability	$< \pm 0.5^\circ$
Mean injection radius	89.3 cm
Mean extraction radius	356 cm
Dee angle	23.5°
Maximum output power of each RF amplifier	300 kW

We developed a new type variable frequency resonator, called movable box type,² to avoid difficulties arisen in a usual coaxial resonator equipped with movable short end;³ one difficulty is of large total height of the resonator and the other is of sliding contact enduring high current density on inner

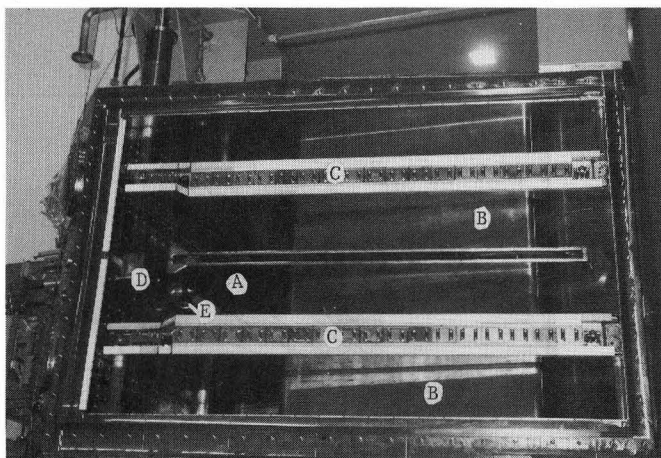

Fig. 1 Picture of the movable box type resonator. A: dee, B: stem, C: movable box, D: capacitive frequency tuner, E: coupler.

+ Sumitomo heavy industries LTD

conductor. Figure 1 is a picture of the new type resonator. The resonator is a half wave length coaxial type in which the delta shaped dee is supported in median plane by vertical stems from the both sides. The resonant frequency is changed by moving a pair of boxes surrounding the stems. Both inductance and capacitance of the resonator are varied by moving the boxes so that travelling distances of movable parts and the total height of the resonator can be extremely saved compared with a usual movable short end type, which varies only inductance. The problem of sliding contact disappears in the new type resonator because the movable boxes are contact only with outer wall where current density is low. Each of two resonators is powered by a separate RF amplifier capable of delivering 300 kW in a frequency range of 17 to 45 MHz². The RF power is fed into the resonator through a 50 Ω coaxial feeder line (~1.8 m length) which is coupled with the resonator in good impedance matching by means of a variable capacitive coupler. All the RF systems had been installed in september 1986 and their performances have been studied.

Structure of the Resonator

Figure 2 shows a cross sectional view of the resonator. The vacuum chamber is divided into two

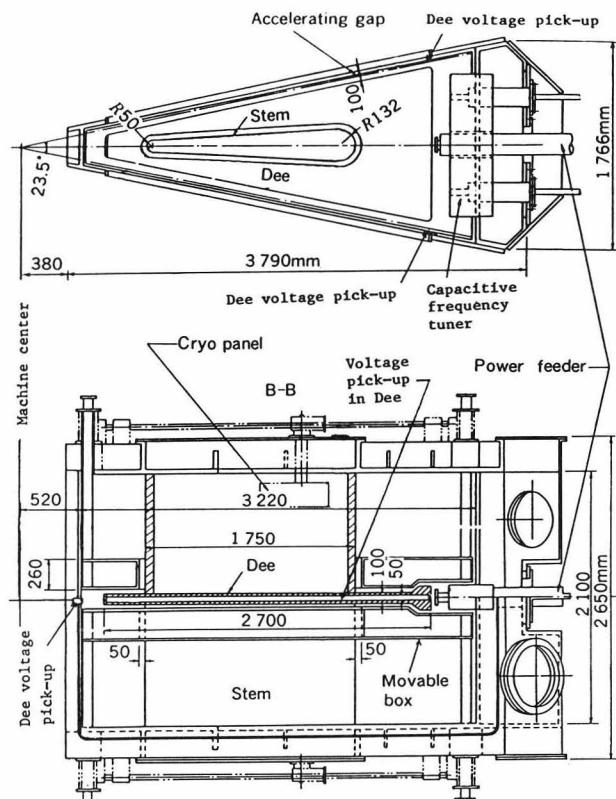

Fig. 2 Cross sectional view of the movable box type resonator.

compartments by a wall having many holes for evacuation. The main part is the RF resonator. The other is an auxiliary space for evacuation and for the fine tuner and coupler. The stem, dee, and outer wall are made of copper-clad stainless steel which has many cooling channels engraved on the surface of stainless steel under the copper overlay. A cryo-panel for evacuation is installed inside the stem. The movable box and fine tuner are constructed from stainless steel frames and copper sheet covers. The movable box is supported by three rods which accommodate the pipings for cooling water and pneumatic pressure. The 50Ω feeder line is passed through the center of the tuner facing the dee end. The movable boxes and capacitive fine tuner are in contact with the outer conductor by sliding contacts made of silver graphite. Sliding contact fingers of the movable boxes are pressed to the outer conductor by pneumatic pressure. The main cryo-pump and turbo-molecular pump are mounted on the outer wall of the auxiliary space. Four sets of capacitive voltage pick-up are provided at positions shown in Fig. 2. Three of them monitor dee voltage and the other one detects RF-electric field inside the dee. All the system are installed on a platform car and can be moved 2 m from the valley space between the magnets leaving the side walls to allow the resonator accessible for maintenance.

Characteristics of the Resonator

Electrical characteristics of the resonators are measured on low-level signals from a frequency synthesizer. The results are compared with the calculation on the basis of one dimensional transmission line approximation². Measured frequencies of the fundamental and higher modes are shown by dots in Fig. 3. The solid line shows the calculated frequency of the fundamental mode and the broken lines show the multiples of measured one. The broken lines cross the higher mode frequencies at several points, where an undesirable higher mode is possibly excited by a higher harmonic component in the RF power. In such a case, the relation between the higher mode and the fundamental mode has to be changed by moving the capacitive tuner and movable boxes. In Fig. 4, the shunt impedance (R_s) defined at the extraction radius

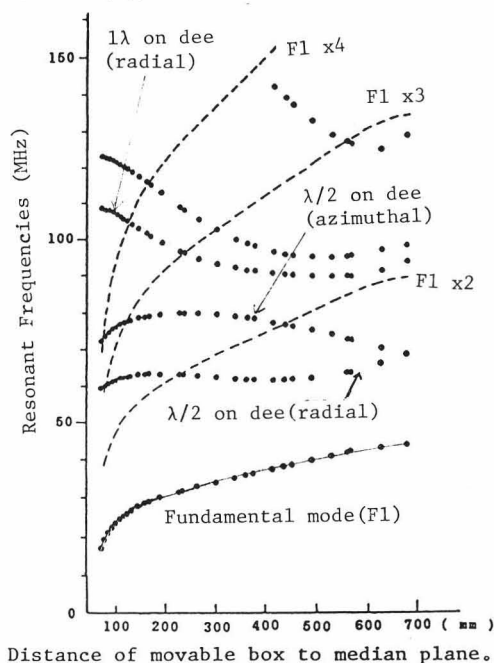

Fig. 3 Resonant frequencies of fundamental and higher modes.

and Q-value (Q) are shown together with the calculations. The Q-value was deduced from the width of the resonance curve which was measured by two capacitive coupler very weakly coupled to the resonator. The shunt impedance was measured by

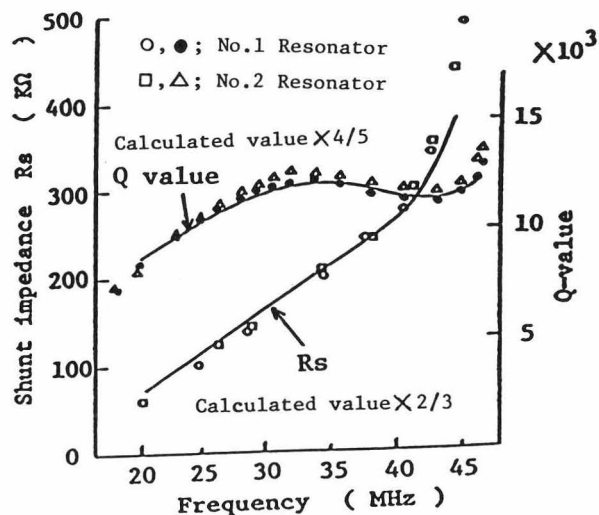

Fig. 4 Q-values and shunt impedance. The lines show the calculations.

perturbation method using a perturber of dielectric ceramic ball to avoid the effect of RF magnetic field. The tuning characteristics in Fig. 3 and frequency dependences of Q and R_s are well reproduced by the calculations, while measured Q is about 4/5 of the calculated one, and measured R_s is about 2/3. Such disagreements are that the structure of the resonator is too complex for one dimensional transmission line approximation and resistances of many contacts are not taken into account.

Relative distributions of RF electric field along the dee gap were measured in the same way for the shunt impedance. The results are shown in Fig. 5, where the dee voltages are normalized near the beam injection radius. The radially increasing voltage distribution are obtained. The dee voltages at the injection and

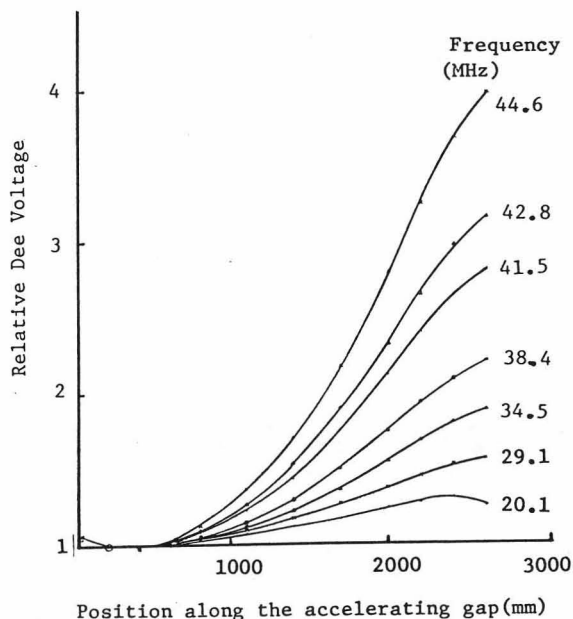

Fig. 5 Relative distributions of RF electric field along the dee gap.

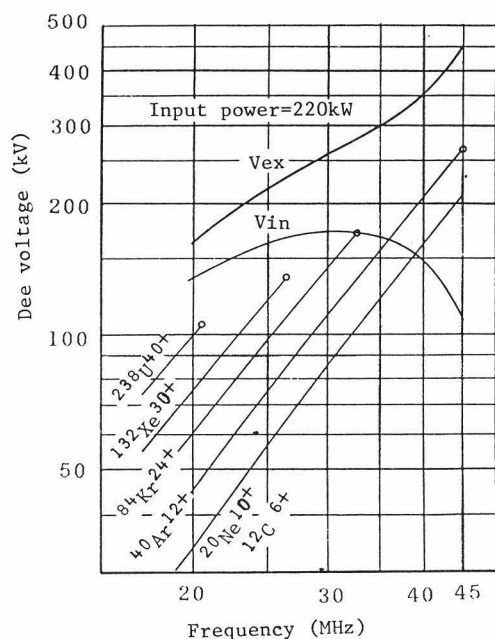

Fig. 6 Dee voltage estimated by low-level test for the input power of 220 kW. V_{ex} and V_{in} are voltages at the extraction and injection radii, respectively. The voltage at the extraction radius required to accelerate various ions are also shown.

extraction radii for the input power of 220 kW are calculated from the shunt impedances and the radial voltage distributions. They are shown in Fig. 6. The input power of 220 kW is enough to generate the dee voltage required for beam acceleration. Even if the resonator was designed mechanically in up-down symmetry, the actual resonator has asymmetry due to the fabrication errors and it causes RF electric field inside the dee. This field is undesirable for the beam acceleration. Furthermore, it might disturb beam diagnostic systems or give rise local heating of the structures. The field (vertical component) was measured with the pick-up in the dee. Figure 7 shows ratio of the electric field inside the dee to that of the accelerating gap against difference between positions of the movable boxes. As we can see, the inner field can be canceled by setting the boxes in asymmetry. The impedance matching condition of the coupler, frequency

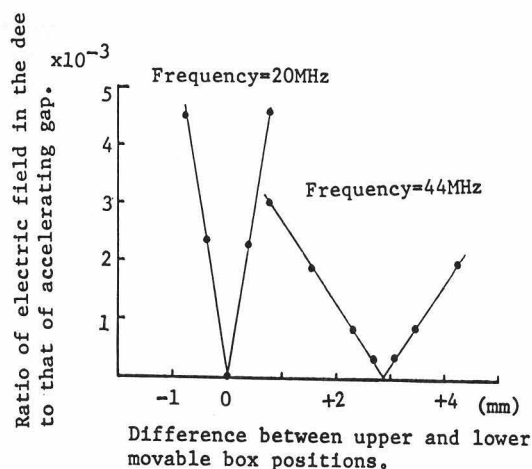

Fig. 7 Ratio of RF electric field inside the dee to that of the accelerating gap. The line is to guide the eye.

changes by the capacitive tuner and coupler were also measured and no difficulty was found.

Power Amplifier

The design study of the amplifier is already reported². Figure 8 shows a block diagram of the amplifier system. An RF reference signal is fed from the RF system of the injector in normal operation, and besides, a local synthesized signal generator is prepared for maintenance. The signal is split to two amplifier systems and a beam buncher system. The resonator is automatically tuned with the capacitive fine tuner and its input impedance is also automatically matched in 50Ω with the coupler by detecting the incident and reflected powers on the feeder line. Acceleration voltage and phase of each resonator are also adjusted automatically by comparing the picked up signals from the resonator with the reference signals. The pulse modulator is used to break through multipactorings in the resonator. The pulse excitation is also applied to find out an exact tuning point of the resonator by sweeping the resonant frequency with the capacitive tuner. Setting and monitoring of all the parameters are done by a central computer.

Figure 9 shows a schematic drawing of the final and driver amplifiers. The SIEMENS RS2042SK is used in grounded grid configuration. The tuning element of the

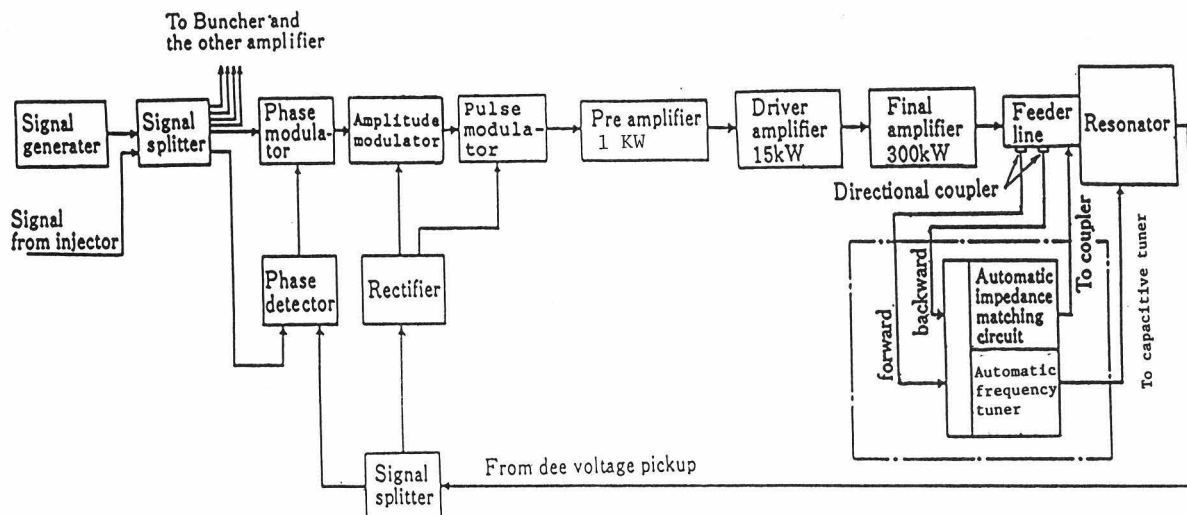

Fig. 8 Block diagram of the Amplifier system.

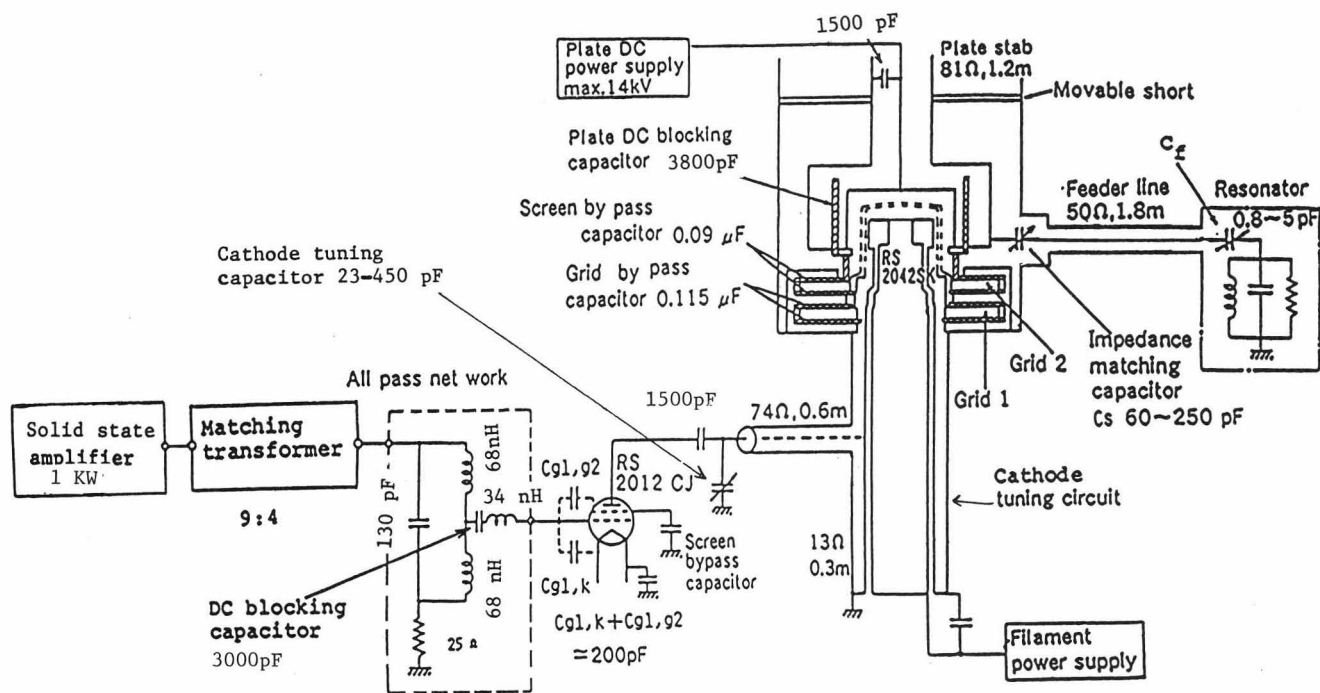

Fig. 9 Schematic drawing of the final and driver amplifiers.

Table 2. Typical operating condition of final and driver amplifier.

Frequency	Pre-Amp. output power	Driver amplifier ($V_p=6.8kV$, $V_{g1}=-125V$, $V_{g2}=800V$)			Final amplifier ($V_p=12.5kV$, $V_{g1}=-340V$, $V_{g2}=1100V$)		
		plate DC current	RF amplitude $E_g(\text{peak})$	$E_p(\text{peak})$	plate DC current	RF amplitude $E_p(\text{peak})$	Output power
17 MHz	450 W	3.1 A	135 V	5.2 kV	36 A	9.6 kV	300 kW
20	350	3	160	5.8	39	10	300
25	400	3.6	150	5	40	11	300
30	480	3.9	160	3.8	37	10.8	324
35	640	4.0	160	4	40	10.7	300
40	640	4	160	4.3	36	8.5	290
45	800	3.4	150	4.7	35	7.8	290

plate circuit is an adjustable $\lambda/4$ coaxial stub whose stroke is 1.2 m. Load resistance matching for the tube is made by a variable capacitor (C_s). The plate DC blocker is a cylindrical capacitor cooled by water (35 cm(h) \times 35 cm (Φ)) whose insulator is made of Kapton film (125 μm \times 16 turns). The screen and control grid bypass capacitors are parallel plate capacitors whose electrode (520 mm Φ) are insulated by 50 μm Kapton films coated by copper. The cathode circuit consists of a variable tuning capacitor and a fixed $\lambda/4$ coaxial stub, through which the filament current is supplied from a power source at ground potential without a filament choke coil. The tuning and impedance matching of the circuit were made throughout the frequency range by only one tuning capacitor. The input circuit of the driver tube RS2012CJ consists of a matching transformer and an all pass network⁴. Table 2 shows the typical operating condition of the amplifier system.

Conclusion

We will start beam acceleration test using Ar^{12+} ions at the frequency of 28 MHz in November 1986. The resonators were powered at the frequency in the vacuum pressure of about 1×10^{-6} Torr. The multipacting arose at the dee voltage of about 300V and it was easily overridden after pulse excitation with input power of about 60 kW. We obtained the dee voltage of 140kV with the input power of 55kW. It is consistent with the shunt impedance measured on the low-level test. The automatic frequency tuning system, the dee voltage stabilizer, and the phase stabilizer were

working well. The dee voltage stability is better than $\pm 1.5 \times 10^{-4}$ and the phase stability $\pm 0.2^\circ$. In near future we will make power test of the RF system throughout the frequency range designed.

References

- <1> H. Kamitsubo, "The RIKEN linear accelerator cyclotron system," *Proc. 10th Int. Conf. Cyclo. and Appl.*, East Lansing, USA, 1984, pp. 257-262.
- <2> T. Fujisawa, K. Ogiwara, S. Kohara, Y. Oikawa, I. Yokoyama, M. Hara, I. Takeshita and Y. Chiba, "Design of the RF system for the RIKEN SSC," *Proc. 10th Int. Conf. Cyclo. and Appl.*, East Lansing, USA, 1984, pp. 311-314.
T. Fujisawa, K. Ogiwara, S. Kohara, Y. Oikawa, I. Yokoyama, I. Takeshita, Y. Chiba, and Y. Kumata, "Design of Radio Frequency system for RIKEN Separated Sector cyclotron," *Scientific Papers of I.P.C.R.* Vol. 79 pp. 12-27, 1985.
T. Fujisawa, K. Ogiwara, S. Kohara, Y. Oikawa, I. Yokoyama, I. Takeshita, Y. Chiba, and Y. Kumata, "Design of Radio Frequency system for the RIKEN Separated Sector cyclotron," *Proc. 1985 Particle Accelerator Conf.*, Vancouver, Canada, 1985, pp. 2897-2899.
- <3> K. Ogiwara, M. Hara and T. Fujisawa, "Design study and model test of RF resonator for the RIKEN SSC," *Report of I.P.C.R.*, NO 57, pp. 222-231, 1981.
- <4> S. W. Mosko, J. D. Raylander, G. K. Schulze, "ORIC RF system preparation for HIRRF," *IEEE Trans. Nucl. Sci.*, Vol. NS-24, pp. 1786-1788, June 1977.