

AXIAL INJECTION SYSTEM FOR THE SUPERCONDUCTING CYCLOTRON AGOR \*

J.P.Schapira<sup>+</sup>, S. Brandenburg<sup>++</sup> and P. Mandrillon<sup>+++</sup>

+IPN Orsay, BP n°1, 91406 Orsay cedex, France  
 ++KVI, Zernikelaan 25, 9747 AA Groningen, Netherlands

+++IN2P3-Paris and Centre Antoine Lacassagne, 06054 Nice, France

1. Introduction

The superconducting cyclotron AGOR, described elsewhere in this conference<sup>1</sup>, is intended to accelerate light and heavy ions with energies ranging from 6 to 200 MeV/A (fig.1). The present paper deals with aspects of the axial injection system, namely the transport and matching sections from the ion sources to the entrance of the yoke, the central region which extends to a radius where electrical accelerating fields have no significant influence on beam emittance and the transport section inside the yoke. These three parts will be discussed in some detail and the results obtained so far show the feasibility of an axial injection into the superconducting cyclotron AGOR, compatible in practice with the complexity of such an accelerator : the study was conducted with the aim of having simple operation, reducing maintenance problems and having the minimum number of elements.

2. Ion sources and beamline system

The cyclotron being designed to accelerate both light and heavy ions, it is foreseen to install in Groningen three ion sources : an ECR source for heavy ions, a light ion source and a source for polarized protons and deuterons. Concerning the source for light ions no choice has been made yet, since available sources do not meet our requirements on intensity for doubly charged helium ions. For polarized ions the presently existing sources deliver beams with too poor quality for injection into the cyclotron. The developments in this field, however, suggest that this problem will be overcome in the near future.

For both mechanical and radio-protection arguments the beam will be injected from below. Since the space available below the machine is very limited the horizontal part of the axial injection beam line will pass through a region with a rather high stray field (up to 100 Gauss). In order to shield the low-energy beam from this field the beam line will be constructed of magnetic steel. Calculations and measurements indicate that in this way the stray field can be reduced to 0.5 Gauss using a wall thickness of about 6 mm for tubes with 100 mm diameter. Eventually the inside of the tubes will be covered with a thin layer of mu-metal to reduce the stray field even further.

Since in Groningen the distance between the source room and the cyclotron axis is about 15 m the depolarization of the polarized particles in magnetic quadrupoles was considered. Because of the rather large emittance of the beams delivered by polarized ion sources the depolarization amounts to 25% over this distance. This was considered unacceptable and thus led to the choice of electrostatic quadrupole lenses as focussing elements. Furthermore the polarized ions also require that the bend to the cyclotron axis is electrostatic.

A lay-out of the system to be used for the tests in Orsay is shown in fig. 1. A Duo-plasmatron type ion source will be used, which allows tests with hydrogen and singly charged helium ions. On basis of the experience gained at the KVI with the axial injection system of the present cyclotron it was at first decided to

use a simple bending magnet and electrostatic deflector instead of more expensive achromatic systems. As a consequence the electrostatic deflector has to be of the spherical type, which is double focussing.

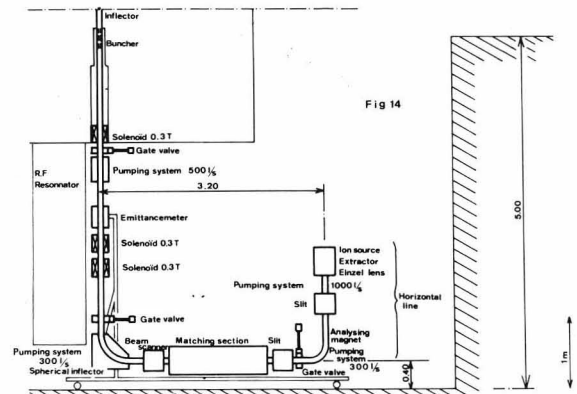

Fig.1 - Setup of the axial injection system to be installed for the tests at Orsay.

For the matching section in principle four quadrupole lenses would be sufficient. However, from the study of the matching to the transport section, which will be installed at the KVI, it was found that matching could be obtained more easily by including one extra quadrupole lens. With the matching system a waist with the dimensions needed for the matching is produced after the electrostatic deflector. The solenoids are then used to transport the beams to the entrance of the yoke, where beam should be parallel or slightly convergent. The calculations were made with a modified version of the code TRANSPORT<sup>5</sup>.

Space charge effects in the setup of fig. 1 have not yet been studied in detail. The space charge compensation which occurs when using magnetic optical elements does not exist with electrostatic focussing. Therefore space charge effects are expected to occur at lower intensities.

Although the system described above allows the proper matching, it is not very flexible. In view of the fact that finally three ion sources with different characteristics will be connected to the system flexibility and modularity are important for a reliable operation. Therefore we consider at the moment the installation of an achromatic system for the electrostatic deflector. In such a case it may be possible to use cylindrical deflectors.

The transport section to be installed between the source area and the area below the cyclotron will consist of a periodic quadrupole structure. The first lenses of this structure will be used to produce a matched beam. The betatron phase advance per cell (two quadrupoles + drifts) for zero current has been chosen to be 60 deg. For a current of 500 µA the acceptance of

the channel is then reduced by about 4%. For the tests in Orsay the intensity will be considerably lower, thus suggesting that space charge effects can be neglected. At the KVI, however, larger currents will have to be transported and space charge effects may be important. A detailed study of these effects is in progress.

### 3. The central geometry

3.1. Basic requirements and parameters. The central geometry, together with the inflector, have been designed to fulfil the requirements reported in ref.2 :

- a - constant orbit mode operation for each harmonic  $h = 2, 3$  and  $4$ .
- b - breakdown voltage limitation both vertically ( $E_z < 27$  kV/cm) and horizontally (Killpatrick criterium) on the inflector and on the dees.
- c - geometrical set-up compatible with the three harmonic modes.
- d - strong R.F. shielding between the three dees and the inflector.
- e - on axis injection.

It turns out, from a), that for each value of  $h$  the central trajectory is completely determined by the initial conditions at the exit of the inflector (injection radius  $\rho$  and the position of the inflector itself) and by the quantity  $Z_i/A B_0^2/V$ , where  $Z_i$  and  $A$  are respectively the charge and the mass number of the ion,  $B_0$  the isochronous magnetic field and  $V$  the peak voltage on the dee. Taking into account the R.F frequency range of 24-62 MHz, the main characteristics of the machine<sup>1</sup>, condition b) and the aim of having for each  $h$  the largest injection radius  $\rho$ , one can relate a maximum value of  $Z_i/A B_0^2$  to each harmonic mode (table 1). The various region of operation with each harmonic mode  $h$  are shown in fig.2.

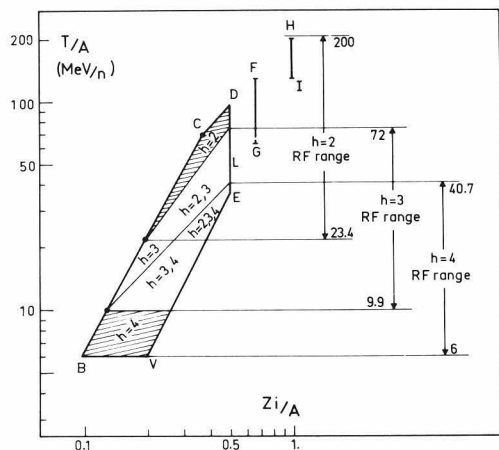

Fig.2 - Diagram ( $T/A, Z_i/A$ ) with various regions of operation with each harmonic mode due to R.F range and voltage breakdown limitations.

3.2. Central geometry design. A central geometry, common to the 3 harmonic modes (fig.3) has been designed together with the inflector (one for each  $h$ ), in order to deliver a centred and isochronous beam after a few turns, to provide enough vertical and radial acceptance and to give the various beams enough energy to pass the central region during the first turn.

#### 3.2.1- Method

The study has been carried out using the discretization method proposed by P. Mandrillon in the case of horizontal motion. In this approach, the action of the electrical field on an ion occurs only at discrete points, located between two successive equipotential surfaces, supposed to be stationary. This hypothesis is justified

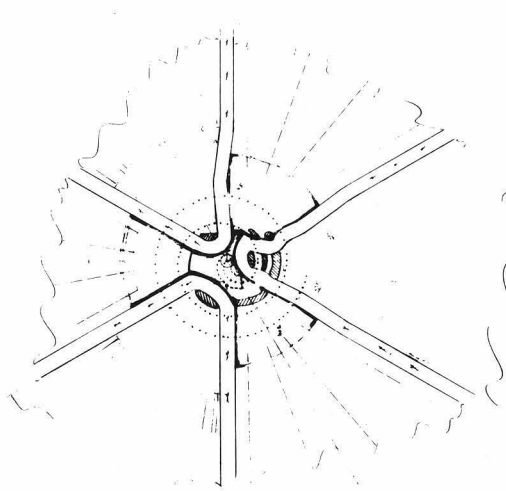

Fig.3 - View of the central region.

because of the strong R.F shielding provided in the central region. Fifteen equipotential surfaces, ranging from 5 to 95% of the total dee voltage have been obtained from electrolytic tank measurements on a model of the central region at scale 5:1. Each equipotential surface is defined by a biparametrical representation deduced from three equipotential lines measured at  $Z = 0., 2.$  and  $5.$  mm. The advantages of this approach are the following :

- no first and hazardous second differentiation of the potential are needed to study the vertical motion, only the normal to these surfaces has to be determined.
- easy change in the central geometry, due to the use of conducting wax allowing quick modifications of sensitive parts<sup>3</sup>.
- moreover, having stored in a computer file the networks of equipotential surfaces associated with each gap it is easy to built synthetic geometries which can simulate mechanical changes (e.g.: moving a dee nose, twisting a dee).

It is felt that this method allows an efficient optimization of the geometry which would hardly be possible with 3-dimensional field calculations. Various computer programs, developed at Orsay, analyse the tank measurements data (TRAFIT) and create synthetic geometries (TWISGA). Three-dimensional orbit calculations are performed by the program AGOVER, which can also take into account the real magnetic field.

#### 3.2.2 - Central trajectory results

The study has been carried out in conjunction with a spiral inflector, whose intrinsic parameters (magnetic radius  $\rho$  and transit time) and angular position are to give the right initial conditions for orbit centring. In order to conciliate vertical focusing and centring, both strongly dependent on the phase, tilting some electrical gaps was found necessary in order to change the phase of the beam at crossing of the gap. A magnetic bump was also necessary to put the phase back to its right value after a certain number of turns. The results, based on specific ions (C, L and B ; see fig.2), take the real magnetic field into account and are summarized in table 1 and figures 4 and 5. Some improvements have to be made for  $h = 4$ .

Table 1 - Central region results

Basic parameters :			
h	2	3	4
$\frac{Z_i}{A} B_0^2$	4.463	2.958	2.058
Spiral inflector			
mag. radius $\rho$ (cm)	1.261	1.614	1.683
transit angle(deg)	178.640	153.709	153.483
gap width (cm)	0.5	0.5	0.5
gap length (cm)	1.0	1.0	1.0
$E_z$ (kV/cm)	27.4	27.1	19.7
Dee :			
aperture (cm)	1.5	1.5	1.5
gap width (cm)	1.	1.	1.
peak voltage (kV)	81.	78.	55.
Characteristics :			
	a)	b)	b)
off-centring (mm)	0.7	0.2	1.4
gain (%) in first gap	63.	75.	41.
gain (%) in 2 <sup>nd</sup> gap	84.	83.	41.
horizontal acceptance:	$22\pi$	c)	c)
vertical acceptance	$32\pi$	c)	c)

a) at turn 13 ; b) at turn 9 ; c) not calculated.

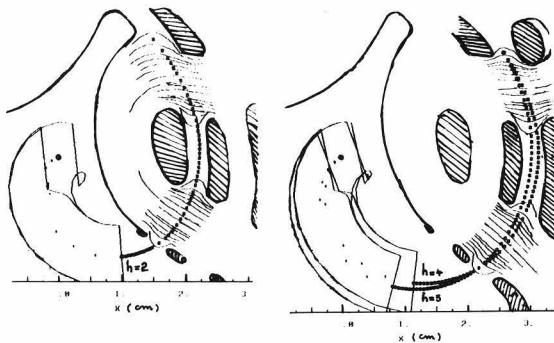

Fig. 4 - The injection of h = 2 in the first hole, and of h = 3, 4 in the second hole.

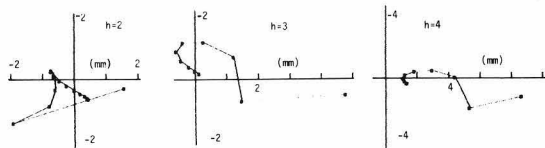

Fig. 5 - Motion of the centre of gravity of the centres of curvature at each turn for specific ions.(C, L and B ; see fig. 2).

3.2.3 - Acceptance for beam C

Vertical and horizontal acceptance have been calculated at the exit of the inflector (N=0) with the program AGOACC, a multiparticle version of AGOVER. The corresponding region in the phase space at R = 14.6 cm (N=13) is also recorded for matching purposes. Results are

shown in fig. 6.

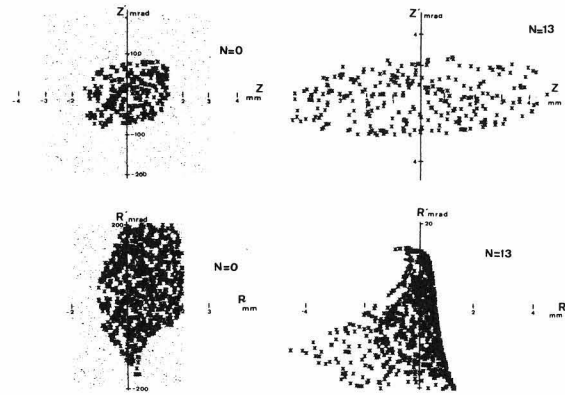

Fig. 6 - Vertical and horizontal acceptance at N=0 and N=13 ; the four other coordinates are equal to zero.

One observes a large vertical acceptance and a limitation  $r < 0$  on the horizontal acceptance due to the 6 mm width of the tunnel in the first injection dee. On the other hand, the two transverse motions in r and z are almost decoupled.

3.3. Matching results for beam C. From the acceptance and the eigenellipses at N = 13 the admittances are found to be  $3.5 \pi$  mm mrad for the horizontal plane and  $8.1 \pi$  mm mrad ( $4.05 \text{ mm} \times 2.0 \text{ mrad}$ ) for the vertical plane. Thus the maximum emittance to be injected is determined by the horizontal admittance.

In order to obtain the emittance at N = 0 the first order transfer matrix between N = 0 and N = 13 has been determined from raytracing with AGOACC. The correlation between radius and energy has been eliminated in order to obtain the transfer matrix for monoenergetic isochronous particles. The emittances obtained in this way at N = 0 amount to  $32 \pi$  mm mrad vertically and  $22 \pi$  mm mrad horizontally.

4. Beam transport for beam C

The backward transport of the vertical and horizontal eigenellipses, determined at N = 0, up to a point located at 3 m from the median plane has been computed with the first order transport program INJAX, developed at Orsay. Because the axial magnetic field does not

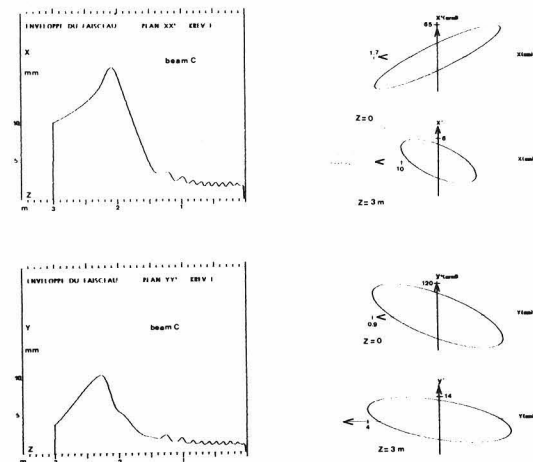

Fig.7 - Transport of the vertical and horizontal eigenellipses (beam c) corresponding to an emittance of  $50 \pi$  at Z = 3m. The current in the solenoid is equal to  $6 \text{ A/mm}^2$ .

extend beyond 1.5 m for beam C one solenoid ( $\phi_{int} = 96\text{mm}$ , length = 250 mm,  $J < 10 \text{ A/mm}^2$ ) has been introduced at 2.1 m, just outside the yoke. Results are shown in fig.7 for beam C.

For protons (beam I,H), a second solenoid might be necessary inside the yoke.

### 5. The bunching system

The aim for this machine is to bunch the beam into  $\pm 15^\circ$  RF phase at the entrance of the accelerating system with the possibility of going to values as low as  $\pm 3^\circ$  RF in the case of light ions.

The solution adopted for AGOR was a single harmonic mode buncher located at around 0.5 m from the median plane in order not to be sensitive to the source noise. It was checked that the increase of vertical beam divergences at the exit of the inflector, due to high velocity modulation ( $\leq 1.6\%$ ) was tolerable for the vertical acceptance of the machine. Because the buncher had to be located inside the yoke, it was desirable to reduce maintenance problems at maximum. It was shown that one buncher instead of three, operating for harmonic 2, 3 and 4, and having no grid was a feasible solution which fulfills the  $\pm 15^\circ$  requirement. To show this, a careful study, using the multiparticle code REGTIR developed at Orsay, was carried on to examine the influence on bunching properties of the beam emittance, the electrical field map (related directly to the buncher geometry and to the presence or not of grids), the axial magnetic field and the inflector. It was found that second order effects, due to the magnetic field, limit the beam emittance (see fig.8), in particular the divergence. In that case using grids has only a marginal effect on the bunching.

The main characteristics are given in table 3 ; it is assumed that the beam is cylindrical and has an upright emittance ellipse at the entrance of the buncher.

Table 3 - Buncher characteristics

h	2	3	4
Beam	H	L	A
V inj (kV)	31.7	31.0	14.1
Length (cm)	5.84	5.84	5.84
Diameter (cm)	2.	2.	2.
Location (cm)	50.	50.	50.
V (Volt)	800.	1050.	700.
X max (mm)	5	5	5
X' max (mrad)	25.	25.	25.
dv/v (%)	1.68	1.59	1.54
Efficiency (%) <sup>a)</sup>	66.	47.	31.
Yield (%) <sup>b)</sup>	50.	50.	50.

a) The efficiency is the ratio of the energy per unit delivered by the buncher to twice the peak voltage ; it is directly related to the transit time.

b) The yield is the fraction of the DC beam bunched into  $\pm 15^\circ$ .

The  $\pm 3^\circ$  RF case has been studied in the same way. Such bunching is in principle achievable with the same buncher, provided the beam emittance is as low as  $2\text{mm} \times 5 \text{ mrad}$ . Space charge effects, estimated from the spherical bunch model<sup>4</sup>, limits injected beam to a value around  $4 \mu\text{A}$  DC (200 MeV protons).

The RF power to the buncher is fed through a 50  $\Omega$  coaxial cable. The tuning is provided by one inductance and two capacitances located outside the yoke (there is no mechanical tuning inside the yoke).

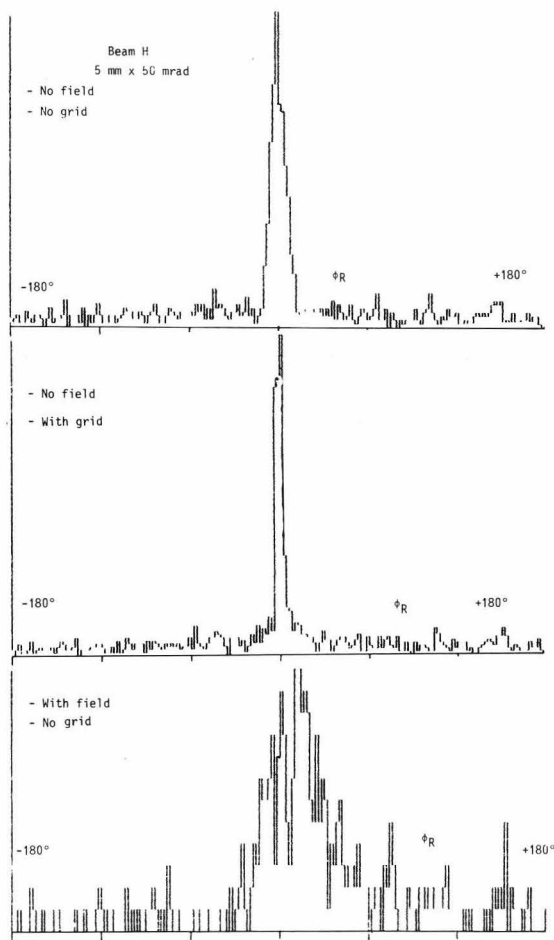

Fig.8 - Time structure after bunching : various effects on bunching properties in the case of beam H .

### 6 - Conclusion

At this date, the main characteristics of the injection system of AGOR have been studied. Some detail studies have yet to be made : beam optics, specially matching conditions, for a set of representative ions, new tank measurements in order to check the validity of the predictions based on the synthetic geometry presented in this paper.

\* Work jointly supported by the INSTITUT NATIONAL DE PHYSIQUE NUCLEAIRE ET DE PHYSIQUE DES PARTICULES(IN2P3), France and by the foundation STICHTING VOOR FUNDAMENTEEL ONDERZOEK DER MATERIE (FOM), Netherlands.

### References

- 1 S. Galès, invited paper at this conference.
- 2 J.P. Schapira and P. Mandrillon, 10<sup>th</sup> Int. Conf. on cyclotrons and their applications, East Lansing, (April-May 1984).
- 3 J. Depauw et al., Report IPNO-GEPL 83-02.
- 4 J.P. Schapira, 9<sup>th</sup> Int. Conf. on cyclotrons and their applications, Caen (Sept. 1981), 307.
- 5 U. Rohrer, SIN version of TRANSPORT, 1979.