

CYCLOTRONS IN 1986

M.K. Craddock  
 Physics Department, University of British Columbia  
 and TRIUMF, 4004 Wesbrook Mall, Vancouver, B.C., Canada V6T 2A3

Summary

Fifty-six years after their invention, the design, construction and improvement of cyclotrons continues at a healthy rate, while their capabilities continue to be extended. Six projects have been completed within the last two years, 13 are under way and 4 more have been approved. The trend is more and more to use superconducting magnets, and in one case a superconducting rf cavity also. The advent of efficient, though expensive, ECR ion sources capable of producing highly stripped heavy ions has killed many PIG sources and is likely to do the same to a number of injector accelerators. Cooling rings, which can store, cool and accelerate beam from a cyclotron, promise powerful improvements in performance and are becoming increasingly popular; five are under construction and more are being proposed. The challenge of high intensity has revealed new problems and provoked new solutions in both beam dynamics and rf control.

Introduction

It is now over fifty years since the first cyclotrons were built. While cyclotrons themselves continue to thrive, as we have heard at this conference, time is beginning to take its toll of the people involved in those early years. The last couple of years has sadly seen the deaths of three major pioneers, and it seems appropriate at the beginning of this talk to pay some brief tribute to their contributions. First and foremost must be mentioned Stanley Livingston, who as the graduate student of Lawrence believed himself to have been the first to make a cyclotron actually work. Subsequently he led the building of larger cyclotrons at Cornell and MIT, then the weak focusing Brookhaven Cosmotron, and following his co-discovery of strong focusing, the Cambridge Electron Accelerator. Next comes Jack Livingood, also involved in the early development of accelerators at Berkeley. Later he played a leading role in the unique application of sector focusing to a synchrotron - the Argonne Zero Gradient Synchrotron. These two are of course also famous as authors of the only major English language textbooks on accelerators. Finally comes Jack Riedel, a great rf engineer and a great character, whose skills were legendary. His last and perhaps most challenging achievements were the rf systems for the MSU superconducting cyclotrons.

With the cyclotron principle dating from 1930 cyclotrons may now reasonably be said to be in late middle age. Even if sector-focusing cyclotrons are regarded as a separate species, their first experimental realization occurred almost 35 years ago, so they are certainly not in their first youth. In trying to pick out the most important themes from a conference in such a mature field one cannot expect to find much in the way of new principles; nevertheless there are some interesting novelties to report. The major advances seem to stem firstly from improved technology, e.g.

superconducting magnets  
 accurate electric & magnetic field computations  
 ECR sources

and secondly from new challenges, e.g.

high intensities  
 coupling to other machines.

Projects Completed and Under Way

Before expanding on these general considerations, however, it will be useful to review those projects which have been completed since the last conference (East Lansing, May 1984) and those which are under construction (see Table I).

The first of those completed and successfully operated was the K520 superconducting cyclotron at Chalk River.<sup>1</sup> As a Canadian, I am delighted to be in a position to offer the community's congratulations to the group which first conceived the idea of the superconducting cyclotron, and commiserate with them on the delays they have suffered for entirely non-technical reasons. Among several novel features the use of trim rods rather than trim coils is noteworthy and has apparently been completely successful. The cyclotron has been operating for more than a year now, delivering various beams to experiments, most recently 20 MeV/<sup>79</sup>Br.

Next comes the initial operation of the small sector-focused injector cyclotron and the large separated sector ring cyclotron for light ions at the South African National Accelerator Centre.<sup>2</sup> 66 and 200 MeV proton beams have been accelerated and extracted. In the former case there is complete turn separation and 100% extraction efficiency. Work is under way on magnet alignment and other improvements to achieve the same conditions at the higher energy.

There is also news of the initial operation of the 56 MeV cyclotron at Krakow and the 20 MeV machine at Debrecen. In addition, two machines have just been completed and are about to start beam commissioning - the magnificent K540 separated sector ring cyclotron<sup>3</sup> which we admired during our tour of RIKEN, and the sector-converted 200 MeV synchrocyclotron at Uppsala,<sup>4</sup> injector for the 1160 MeV CELSIUS cooling ring. [Alpha particles were successfully accelerated to full energy at Uppsala early in November 1986.]

For the future, Table I shows that more and more cyclotrons plan to use superconducting magnets. The impressive room temperature machines under construction at Lanzhou<sup>5</sup> (K450) and Dubna<sup>6</sup> (U400M) and planned for Osaka<sup>7</sup> (400 MeV protons) may well be the last in the heroic age of cyclotron magnets. Instead it seems that we shall pass to the heroic age of cyclotron cryogenic systems! The temptation is clear enough, as Henry Blosser<sup>8</sup> has pointed out (Fig. 1). On average, superconducting cyclotron magnets can produce the same bending power as room temperature magnets with only 1/17 the mass of steel.

Of particular interest is the application of superconducting magnets to medical cyclotrons, where

Table I. New Cyclotrons.

Cyclotron	Energy	Particles <sup>†</sup>	Date
<u>Recently completed</u>			
*AECL Chalk River	K520		1985
NAC (S. Africa) SFC	8 MeV	p + L.I.	1986
SSC	200 MeV	p + L.I.	1986
Krakow	56 MeV	p + L.I.	1986
Debrecen	20 MeV	p + L.I.	1986
Uppsala SC <sup>§</sup>	200 MeV	p + H.I.	1986
RIKEN Ring SSC	K540		1986
<u>Under construction</u>			
Louvain	30 MeV	H <sup>-</sup>	1986
*MSU/Harper Hospital	50 MeV	d	1987
*MSU	K800 (1200)		1987
*Texas A&M	K500		1987
Swierk	30 MeV	H <sup>-</sup>	1987
Lanzhou HIRFL SFC	K69		1987
SSC	K450		1988
*Milan/Catania	K800		1988
Dubna U400M	K540		1988
NAC (S. Africa)	K11	p̄ + H.I.	
Warsaw	K180		
*Munich TRITRON	K85	p + H.I.	
Bombay	35 MeV	p + L.I.	
<u>Approved projects</u>			
Osaka RCNP	400 MeV	p + L.I.	1991
*Orsay/Groningen AGOR	K600		1991
Jyväskylä	K100		
*Amersham/Oxford Instr.	12/17 MeV	H <sup>-</sup>	
<u>Proposals</u>			
*MSU Medical SC	285 MeV	p	
*EULIMA SSC	>300 MeV/u	L.I.	
*Munich SOC	K2400		

\*Superconducting magnets

<sup>†</sup>Heavy ions where not otherwise stated

<sup>§</sup>Synchrocyclotron conversion to sector-focusing

the lowering of costs could lead to much more widespread use of cyclotrons in hospitals. The MSU/Harper Hospital K100 mini-cyclotron,<sup>8</sup> designed for mounting in a rotatable gantry for neutron therapy, should be complete in early 1987. The Amersham/Oxford Instruments 12/17 MeV micro-cyclotron<sup>9</sup> will offer the ultimate in compactness. More ambitious are schemes for 300 MeV superconducting machines for proton and light ion therapy - a synchrocyclotron being designed by MSU<sup>8</sup> and a separated sector cyclotron EULIMA by a European consortium.<sup>10</sup>

#### High Intensities

Here new ground is being explored by the SIN group,<sup>11</sup> who for almost the first time are observing strong space charge effects within a cw cyclotron equipped with an external ion source. With their new 0.86 MeV Cockroft-Walton pre-injector they can present 16 mA dc to their new separated sector Injector II. From this they can extract about 1.0 mA for about 2 μA beam loss, but this goes up to about 10 μA, the maximum tolerable, for a rise in beam intensity of only 10%. The increased loss is associated with increased energy spread (~0.45 MeV/mA), which is attributed to second-order longitudinal space charge effects (linear effects are compensated with the help of third harmonic rf

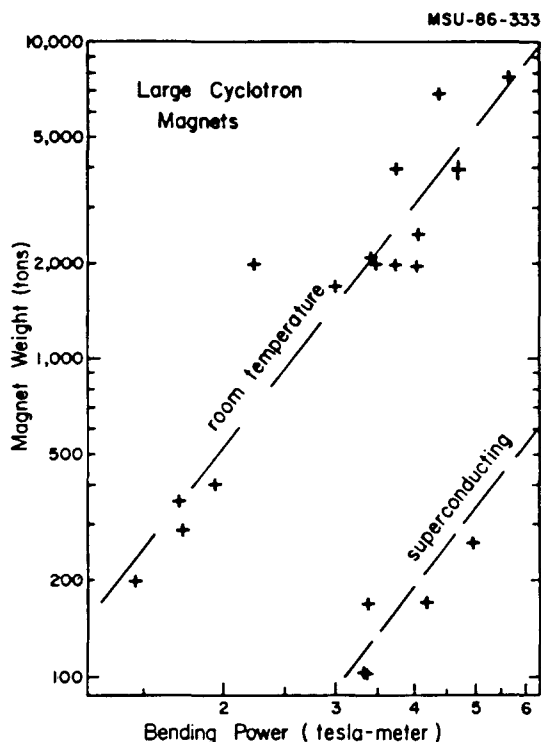

Fig. 1. Magnet weight versus bending power for a number of large cyclotron magnets.

flat-topping). Computer simulations have revealed a 'spiral instability' during the first turns in Injector II, perhaps associated with the 'vortex motion' described by Mort Gordon.<sup>12</sup> Because the 590 MeV ring cannot accept a beam with an energy spread of more than 0.3 MeV, the maximum current that can be accelerated at present is 0.65 mA. In practice the upper limit for cw beam is 0.35 mA, set by the limitations of the secondary production target, the beam stop and the rf power supply.

Regarding rf, both cyclotrons are in the interesting and novel situation that beam loading is a major effect. The present 200 kW power amplifier for the fundamental frequency is essentially at its limit for a 0.35 mA beam. For higher currents it is planned to build a new 600 kW system. This would also enable the peak voltage to be increased from 500 kV to 700 kV with various rf and beam dynamic advantages. In order to flat-top the rf, the third harmonic cavities are run in antiphase with the fundamental. As a result, beam-loading effects on them are negative, the power required decreasing with intensity as the beam delivers power to the rf system. For currents greater than 0.8 mA in Injector II and 0.5 mA in the ring the third harmonic power required is actually negative. From the point of view of supplying power this sounds delightful, but from that of maintaining control it is very dangerous, as the system plays the role of a proton klystron, with power being fed in at the fundamental frequency and part of it coupled out at the third harmonic. To control the amplitude and phase a prototype feedback loop has been developed and successfully tested. The cavity voltage and phase can be maintained essentially constant while developing high voltage but delivering no power. A further problem is designing a system which can handle both high and low beam loading conditions. A design is being investigated to cope with this by making the transmission line and generator relatively immune against power reflections. The tube is run in either Class A or AB and external absorbers are used to preload the resonators and optimize the working line.

Table II. Coupling between cyclotrons and other accelerators.

Project	Energies	Ions <sup>†</sup>	Date
<u>Tandem Van de Graaffs</u>			
Duke Cyclo-Graaff	15 MeV → 7 MV	H <sup>-</sup>	1968
Livermore	15 MeV → 7 MV	H <sup>-</sup>	1969
Oak Ridge (HHIRF)	25 MV → K100		1981
Chalk River (TASCC)	13 MV → K520		1985
Berlin (VICKSI)	8 MV → K130		1986
Milan/Catania	15 MV → K800		1988
Munich (TRITRON)	13 MV → K85	p, H.I.	
<u>Linacs</u>			
RIKEN	16 MV → K540		1986
<u>Cooling Rings</u>			
Indiana (IUCF)	200 MeV → 500 MeV	p, L.I.	1987
Tokyo (TARN II)	K67 → K1800	p, H.I.	1987
Uppsala (CELSIUS)	K200 → K1870	p, H.I.	
Jülich (COSY)	45 MeV → 2500 MeV	p, L.I.	
Osaka (RCNP)	400 MeV → 1600 MeV	p, L.I.	
<u>Synchrotrons</u>			
TRIUMF (KAON F.)	450 MeV → 30 GeV	H <sup>+</sup> , p	

<sup>†</sup>Heavy ions where not otherwise stated.

Coupling to Other Machines

The coupling of cyclotrons to other accelerators has been widely employed over the last twenty years, and has been reviewed in some depth by Bob Pollock.<sup>13</sup> A nonexhaustive list of such couplings is given in Table II. Coupling to tandem Van de Graaffs and other cyclotrons has become almost commonplace, with VICKSI a recent addition in the former class. Coupling to linacs has been rarer, with ALICE at Orsay the only example until its closure in 1985. A replacement is imminent, however, at RIKEN, where the variable-frequency linac will be used for heavy ion injection into the new K540 separated-sector cyclotron. The recent trend, however, has been away from the use of other accelerators as injectors to cyclotrons in favour of the use of the enormously powerful electron cyclotron resonance (ECR) ion sources. R. Geller,<sup>14</sup> C.M. Lyneis<sup>15</sup> and others have already reviewed at this conference the continuing progress that is being made in source performance, particularly in providing fully stripped ions of higher and higher mass. In some cases, as in Michigan, plans to use an accelerator injector are being reconsidered (Fig. 2). We have been told that these ECR developments spell 'the death of the PIG'. Perhaps a suitable slogan for this revolution would be

'The ECR is easier'

The other trend which has gained favour in recent years is the addition of a 'cooling ring'. This somewhat inadequate term covers a number of options, including storage, cooling and acceleration. These projects are described in individual papers and have been carefully reviewed by Dieter Möhl.<sup>16</sup> They are clearly going to prove very powerful additions to their host accelerators. Good progress is being made in construction of the front-runners, at Bloomington<sup>17</sup> (IUCF), Tokyo<sup>18</sup> (INS-TARN II) and Uppsala<sup>4</sup> (CELSIUS), and their initial operation is eagerly awaited.

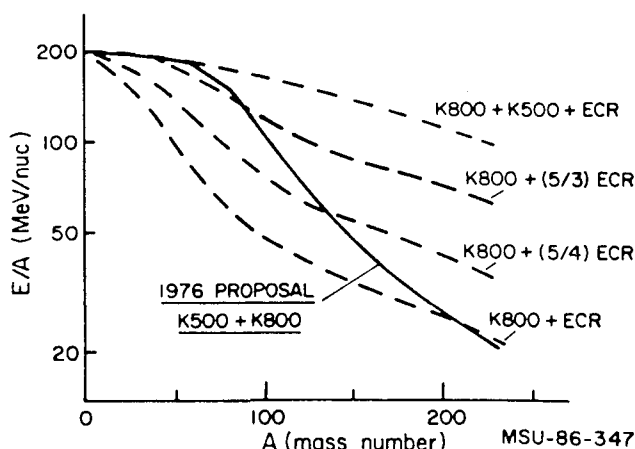

Fig. 2. Energy per nucleon plotted against mass number for various combinations of ion source and cyclotrons at MSU (the fractions represent charge state improvement factors).

Novelties

True novelties are rare in a field as mature as cyclotron design, but are all the more precious for that. Having identified them, though, the question remains whether these new branches of the evolutionary tree represent healthy lines of development or just dead-ends. Only time will tell!

A number of interesting technological innovations were reported, particularly in beam diagnostics and vacuum techniques, but I shall restrict myself to discussing some broader issues. I am also going to mention a couple of topics not covered at the conference but which appear to fit in most appropriately under this heading.

Radioactive Analogue Ion Acceleration

This novel technique, developed by Mallory et al. at MSU,<sup>19</sup> involves the capture and acceleration of nuclear reaction products with the same charge/mass ratio as the primary particle, produced on an internal target at intermediate radius. With a primary <sup>6</sup>Li<sup>2+</sup> beam they were able to observe acceleration of <sup>6</sup>He for the first time, as well as <sup>3</sup>H, <sup>9</sup>Li and <sup>12</sup>Be (Fig. 3). It seems as if this technique may have considerable possibilities for the production and acceleration of short-lived isotopes, provided that the activity generated by such a target can be tolerated.

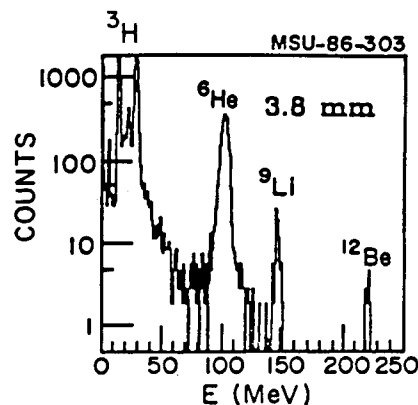

Fig. 3. Observation of various short-lived isotopes accelerated from an internal target.

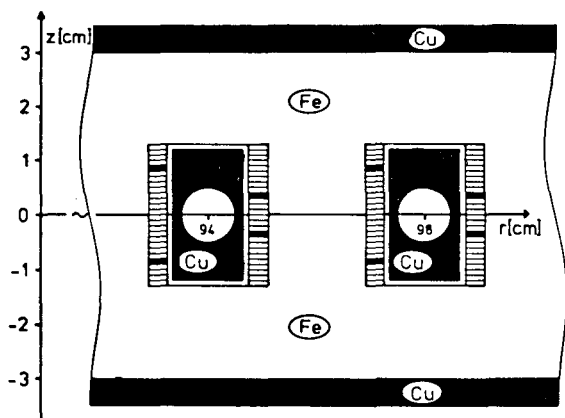

Fig. 4. Vertical cross section through a TRITRON magnet sector, showing two radially adjacent beam channels, individually equipped with superconducting coils and copper shielding.

Superconducting Separated Orbit Cyclotrons

The Munich group's proposal<sup>20</sup> to use superconducting magnets for a separated orbit cyclotron could breathe the new life into a concept that had appeared doomed because of its size and expense. Their prototype K=85 'TRITRON' is completely cryogenic and entirely enclosed in the vacuum chamber. This will be the first time that superconducting rf cavities have been used on a cyclotron. The magnet itself is very modest in size, consisting of 12 sectors, each 6 cm high (Fig. 4), and about 90 cm in radial extent, and containing twenty 2 cm x 2 cm openings to contain the coils, copper shielding and a 1 cm diameter beam aperture (the beam will be injected from a 13 MV tandem Van de Graaff with small emittance). The separated orbit design retains the cyclotron virtues of fixed magnetic field and rf frequency, giving cw beam with high intensity, while permitting individual control over the magnetic field in the beam apertures and hence over the focusing. As a result the machine may be both isochronous and possess phase focusing. Hinderer<sup>21</sup> has described the present status of construction. The future progress of TRITRON is likely to be followed with close attention.

Decyclotrons

Deceleration is a well-known possibility in accelerators, and has been used recently to good advantage at CERN to decelerate antiprotons in the PS and in LEAR. More modestly it has been used for several years in the TRIUMF cyclotron as a diagnostic tool in measuring the absolute value of the beam phase<sup>22</sup> (Fig. 5). Two current applications of deceleration in cyclotrons may not be so well known.

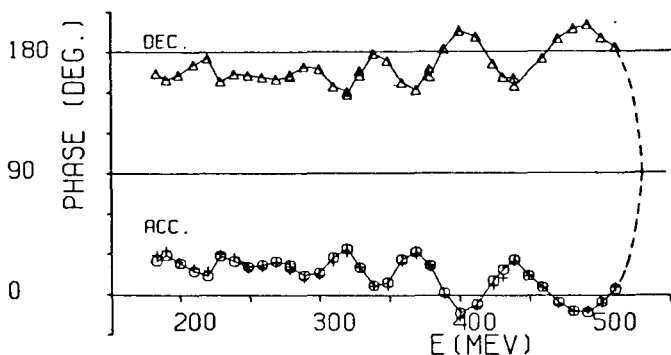

Fig. 5. Measured phases of accelerating and decelerating beams in the TRIUMF cyclotron.

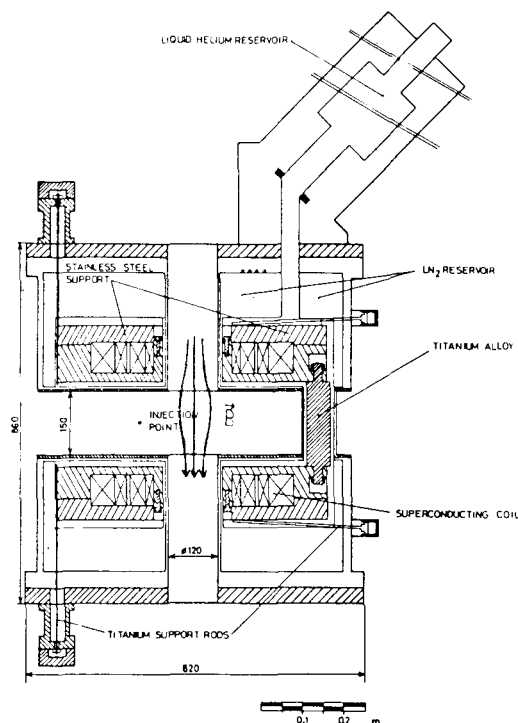

Fig. 6. Superconducting split coil system of the 'cyclotron trap'.

Simons's 'cyclotron trap'<sup>23</sup> (Fig. 6) has been developed at SIN, with the help of W. Joho et al., to stop  $\mu^-$  particles in a localized area of gas. The 110 MeV/c muons enter a 4 T magnetic field with  $n \approx 0.5$  focusing produced by a superconducting solenoid, and in the presence of air are slowed down in reverse cyclotron orbits to stop in a narrow region around the axis. The trap has now been moved to CERN and is performing the same function for antiprotons at LEAR.

The European Hadron Facility is being designed to produce proton (and hence antiproton) beams a hundred times more intense than those available at present. At such intensities stochastic cooling will be ineffective and to obtain cool beams it is therefore necessary to decelerate the antiprotons from the peak production energy at about 2.5 GeV to energies suitable for electron cooling (~200 MeV). For this a decyclotron appears to have some convenient features and is being considered by the EHF study group.<sup>24</sup> Such a machine might have some features similar to those of ASTOR,<sup>25</sup> operated in reverse.

FFAG Cyclotrons

Fixed Field Alternating Gradient accelerators have often been termed synchrotrons. This is surely incorrect as they possess the characteristic features of cyclotrons, namely a fixed magnetic field and an increasing orbit radius. They are in fact ring synchrocyclotrons with sector or spiral focusing. Although the FFAG concept lay dormant for many years following the initial MURA design work, it has recently come into vogue again with the desire for very high intensity (milliamperes) accelerators for spallation neutron sources at around 1 GeV. FFAG designs were proposed for the Argonne ASPUN<sup>26</sup> (Fig. 7) and the SNQ at Jülich.<sup>27</sup> Although these projects are dead a study group is now considering a suitable design for a European spallation neutron source to be based at the Rutherford-Appleton Laboratory using the existing 800 MeV ISIS synchrotron as a storage ring and a new accelerator to raise the

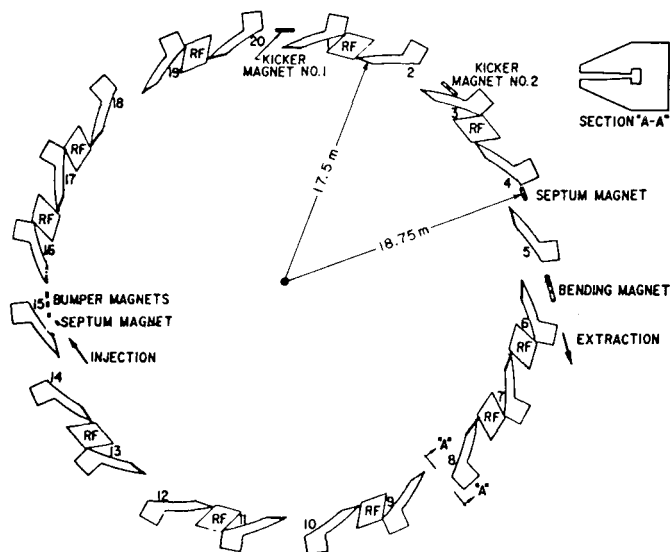

Fig. 7. Layout of the 1.1 GeV ASPUN FFAG proposal.

intensity to 3 mA. An FFAG cyclotron is being considered for this purpose. If work on FFAG cyclotrons continues it would seem appropriate to include it as a topic for future conferences in this series, in view of the similarity of the technology involved - dc magnets with sector focusing, rf cavities with extended accelerating gaps, large vacuum systems, etc.

#### Conclusion

Turning back to Table I we see that there are at present 13 cyclotrons under construction and four more approved. This is clearly a healthy state of activity and we can look forward at the next meeting to many reports of initial operation. If the 'dreams' or unapproved proposals appear few in number, they make up for that in ambition. Their rarity may indeed be a healthy consequence of the high state of construction activity. After all, a dreamless sleep is the usual result of well-performed hard work.

Finally I must comment on one of the overwhelming impressions that delegates must have received at this, the first meeting in this series to have been held in Asia - an impression that is received from various sources - from the conference sessions, from our visits to the local laboratories, and from Professor Hirao's memorable account of the history of accelerators in Japan - that is, of the vitality of the cyclotron community in this country. The projects under way are ambitious and imaginative, the development of technology is impressive, the close involvement with industry is

worthy of imitation, and the range of applications is outstanding. On top of this our hosts have provided an outstanding conference, whose smooth running and hospitality future organizers will find it hard to match. On behalf of all the delegates I would like to record our thanks to Professor Hirao, Professor Kamitsubo, Professor Miura, and their staffs for an excellent meeting.

#### Acknowledgements

I am very grateful to those who have kindly provided information and illustrations for this paper, to Ada Strathdee for her usual care and efficiency in putting it together, and to Richard Baartman, George Mackenzie and Harvey Schneider for their helpful comments.

#### References

1. J.A. Hulbert, these proceedings, paper A1.
2. A.H. Botha, H.N. Jungwirth et al., *ibid.*, A2/L6.
3. H. Kamitsubo, *ibid.*, A3.
4. S. Holm, D. Reistad, *ibid.*, H45.
5. B.-W. Wei, *ibid.*, E3.
6. R.Ts. Oganessian, *ibid.*, J2.
7. I. Miura et al., *ibid.*, H20.
8. H. Blosser, T. Antaya et al., *ibid.*, E1.
9. M.F. Finlan, M.N. Wilson, *ibid.*, L50.
10. Y. Jongen, P. Mandrillon et al., *ibid.*, D31.
11. W. Joho, *ibid.*, B2.
12. M.M. Gordon, Proc. 5<sup>th</sup> Int. Cyclotron Conf., Oxford, 1969, ed. R.W. McIlroy (Butterworths, London, 1971), p. 305.
13. R.E. Pollock, Proc. 9<sup>th</sup> Int. Conf. on Cyclotrons, Caen, September 1981, ed. G. Gendreau (Les Eds. de Physique, Les Ulis, 1982), p. 731.
14. R. Geller, these proceedings, paper M1.
15. C.M. Lyneis, *ibid.*, M2.
16. D. Möhl, *ibid.*, C1.
17. R.E. Pollock, *ibid.*, C2.
18. T. Katayama, *ibid.*, C3.
19. M.L. Mallory, *ibid.*, J1.
20. U. Trinks, Proc. 10<sup>th</sup> Int. Conf. on Cyclotrons, East Lansing, May 1984, ed. F. Marti (IEEE, New York, 1984), p. 605.
21. G. Hinderer, these proceedings, paper G1.
22. M.K. Craddock, E.W. Blackmore, G. Dutto et al., IEEE Trans. NS-24, 1615 (1977).
23. R. Abela, L.M. Simons et al., SIN Newsletter No. 16 (January 1984), p. 65.
24. C. Tschalär, private communication.
25. W. Joho, Proc. 10<sup>th</sup> Int. Conf. on Cyclotrons, East Lansing, May 1984, ed. F. Marti (IEEE, New York, 1984), p. 611.
26. T.K. Khoe, R.L. Kustom, IEEE Trans. NS-30, 2086 (1983).
27. P.F. Meads, Jr., G. Wüstefeld, IEEE Trans. NS-32, 2697 (1985).