

CONTROL ELECTRONICS FOR THE CIME RF SYSTEM

J.F. LEYGE, M. DI GIACOMO, B. DUCOUDRET  
M. LECHARTIER, G. SCHMIECHEN, L. MENAGER, C.DOUTRESSOULLES

GANIL bd Becquerel BP5027 F-14076 CAEN cedex, France

The paper describes the characteristics of the amplitude and phase loops for the accelerating voltage, the control system which manages securities, sparks and multipactor problems for the cavities. Design methods and results during first power tests are presented.

1 General characteristics :

The cyclotron 'CIME' (Cyclotron d'Ions Moyenne Energie) is planed to accelerate radioactive ions in the SPIRAL project. It has 2 RF resonators.

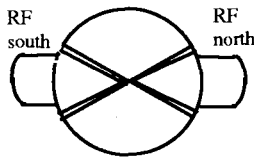

The working frequency range is from 9.6 MHz to 14.5 MHz .

The other characteristics are :

acceleration voltage (kV)	min :15 max : 85
$\Delta f/f$ for secondary beam	$10^{-2}$ : 96kHz to 145 kHz
quality factor in charge $Q_e$	3650 (14.5) to 4550 (9.6)
probe (loop) attenuation	30 dB
probe phase	$0^\circ, 180^\circ$
tuning control	$\pm 5^\circ$
amplitude control	$1.10^{-4}$
phase control	$\pm 0.2^\circ$

2 The automatic control electronic must deal with three principal regulations in order of importance :

- a . the fine tuning of the cavity, two plungers correct the thermal drifts, to keep the cavity centered on the desired frequency.This control is based on the phase between the injected signal and the return signal of a pick-up.  
Then the error signal is filtered and amplified to drive the motors which move the plungers.
- b. the amplitude control. The amplitude of the RF signal must be stable to  $1.10^{-4}$  .
- c. the control phase. The RF phase in a cavity must be stable within  $\pm 0.2^\circ$  and also between the 2 resonators or buncher.

3. Automatic control logic:

Sparks, multipactoring

At the start, an Rf signal is sent in the cavity with a rapid transition to pass over the multipactoring. When the RF is on, an electronic card gives the information of RF presence. When the RF is not present,for example with a spark, a monostable cuts the signal during 150-200ms to allow the evacuation of the particules produced. When the number of sparks is too important (vacuum problems) the automatic control system stops the process. Another system cuts the signal with the same monostable when the reflected wave of the power amplifier is too high to avoid the shutdwon of the supply .

4. Amplitude regulation :

To achieve a good stability, ( $1.10^{-4}$  , in the frequency domain, the modulation frequencies around the carrier must be 80 dB below), we must use a control system constituted of many filters. The principal causes of pertubations are some modulations due to main supplies , (50, 100, 150 ,300 Hz ), some aperiodic undulations due to thermal phenomena, mechanical phenomena, the beam loading ...

Here a simple calculation which shows the effects of a loop to regulate the RF level :

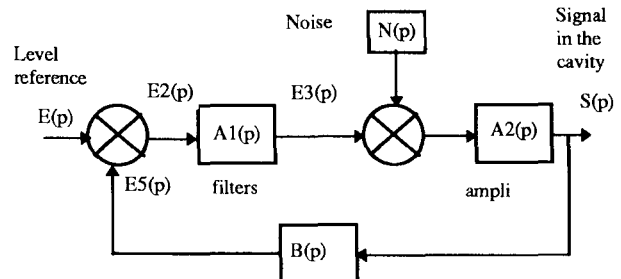

We have :

$$S(p)=[E2(p).A1(p)+N(p)].A2(p) ;$$

$$E2(p)=E(p)-B(p).S(p)$$

$$S(p) = \frac{E \cdot A1 \cdot A2}{1+B.A1.A2} + \frac{N \cdot A2}{1+B.A1.A2}$$

We can see that the low frequency perturbations can be easily reduced, with low-pass filters (or integrator) in the first part of the regulation chain (A1, active filters).

In order to reach the precision of the regulation and to keep the stability, we took the same kind of loop used already for the GANIL cyclotron with possibilities of improvements and modifications.

The first thing to do is to compensate the attenuation of the low-pass elements of the system : typically the cavity and the electronic modulator. Then we examine if the values of the filters may give a sufficient gain to obtain the precision with a good stability. If not, we can add more filters .

The current configuration is :

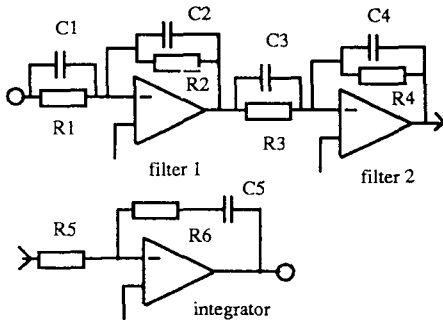

The gains of the filters 1 and 2 are :

$$G1 = - \frac{R2}{R1} \frac{1 + i \cdot R1 \cdot C1 \cdot p}{1 + i \cdot R2 \cdot C2 \cdot p}$$

$$G2 = - \frac{R4}{R3} \frac{1 + i \cdot R3 \cdot C3 \cdot p}{1 + i \cdot R4 \cdot C4 \cdot p}$$

the gain of the integrator is :

$$G = - \frac{1 + i \cdot R6 \cdot C5 \cdot p}{1 + i \cdot R5 \cdot C5 \cdot p}$$

In the integrator the value R6.C5 corresponds to the cut-off frequency of the cavity when it is tuned.

The first filters increase the gain at very low frequencies and allow to keep stability.

Another problem appears if we want to avoid oscillations at any level of voltage in the resonator. Pratically, to change the power sent to the cavity, we change the attenuation of a voltage control attenuator in the regulation chain. So the total gain changes and the stability curves (gain and phase) show possibilities of oscillation, the phase margin may be not respected any more. Furthermore the power amplifier gain is not constant and increases when the signal increases. To solve this , we multiply the error signal (which modulate the RF) by 1/Vréf. Vréf corresponds to the level in the cavity.

The amplitude regulation scheme :

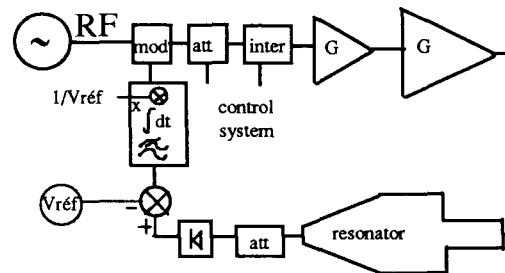

With the choosen control system we plot the gain and phase of the open loop to verify the whole stability.

The calculations have been made with the software AWB (analog workbench) of Cadence.

Gain and phase in the open loop :

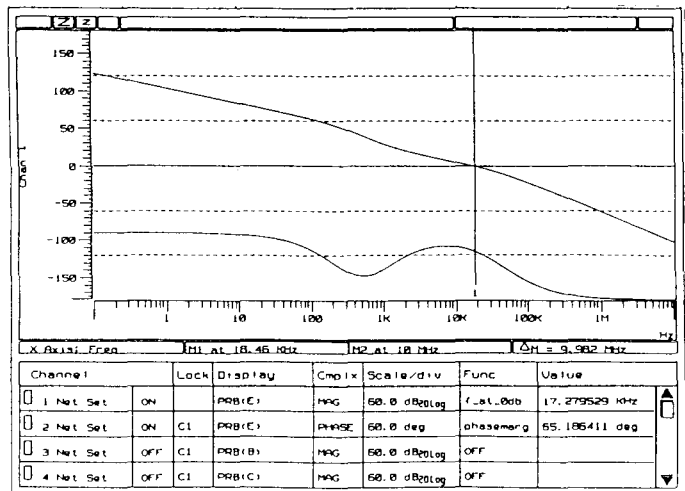

The phase margin is 65° and the frequency is 17 KHz for 0 dB.

The present solution has an disadvantage point : if we have to attenuate strongly low frequency perturbations, we must increase the gain and the system will go in oscillations and of course in disjunction of power supplies.

Considering that the cut-off frequencies of operational amplifiers, power amplifiers, amplitude detector are over 100 KHz they are not considered in the calculation and we could compensate the phase change to keep always -90° in the interested area. In consequence it could be possible to adjust as much as we want the gain to reduce the perturbations.

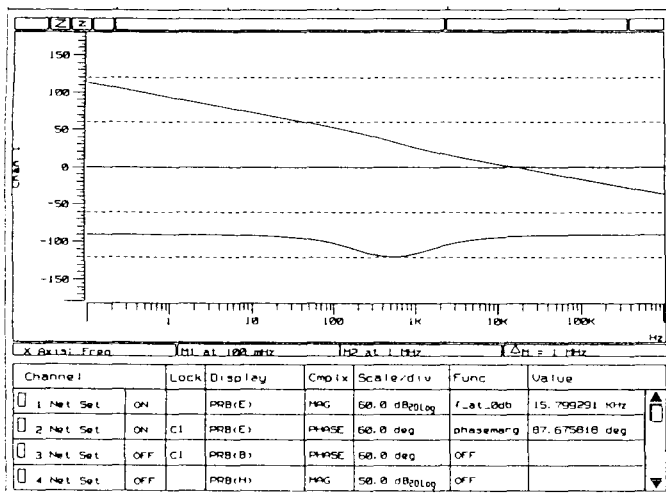

5. Phase regulation :

The phase regulation loop is made after the amplitude regulation. It consists of more simple filters which are sufficient to insure the required stability.

The chosen filters are the following :

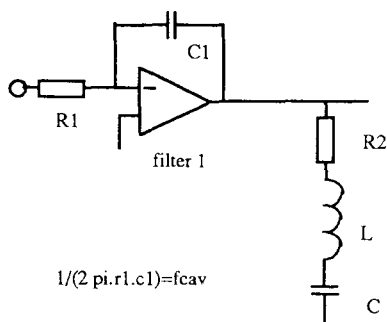

The integrator has a constant  $R1c1$  corresponding to the cavity time constant (1.5KHz) as in the amplitude loop.

To control the phase stability and phase settings of the cavities a multiplexer with a vectore voltmeter and phase shifters are used. To verify the phase system it's possible to simulate the cavities and to see the phase errors from a terminal.

6. First results :

The first tests had been made at 14.4 MHz. Without any regulations and without the cyclotron magnetic field in CIME, it's impossible to hold voltages higher than 40 kV for a long while . Oscillations appear and the system switches to stand-by. The magnetic field attenuates the oscillations and the system is more stable. A 37 Hz spectrum line can be observed due to an unknown phenomenon, 50 Hz and especially 150 Hz spectrum lines are also present.

When all regulations are on, the signal is very clear and meet the specifications. The line spectrum shows a difference between 75 and 85 dB below the 14.4 MHz carrier without any special isolation.

The major problem is to eliminate ground currents which prevent to analyse the signal. The art consists in correctly grounding and isolating all the parts (even if they are far from each other).

In conclusion :

The systems realized are working quite well, some adjustments will be done soon to obtain a more reliable and accurate system .