

## DEVELOPMENT OF A BUNCH FREQUENCY MONITOR FOR THE PRELIMINARY PHASE OF THE CLIC TEST FACILITY CTF3

A. Ferrari\*, A. Rydberg, Uppsala University, Sweden  
 F. Caspers, R. Corsini, L. Rinolfi, F. Tecker, CERN, Geneva, Switzerland  
 P. Royer, Université de Lausanne, Switzerland

### Abstract

In the framework of the CLIC RF power source studies, the feasibility of the electron bunch train combination by injection with RF deflectors into an isochronous ring has been successfully demonstrated in the preliminary phase of CTF3. A new method, based on beam frequency spectrum analysis, was experimented to monitor this scheme. A coaxial pick-up and its read-out electronics were designed and mounted in the CTF3 ring to allow comparison of the amplitudes of five harmonics of the fundamental beam frequency (3 GHz) while combining the bunch trains. The commissioning of the monitor was a successful proof of principle for this new method, despite the short length of the bunch trains and the presence of parasitic signals associated to high-order waveguide modes propagating with the beam inside the pipe.

### INTRODUCTION

The Compact Linear Collider (CLIC) RF power source is based on a new scheme of bunch frequency multiplication: a 30 GHz drive beam is obtained by combining electron bunch trains in isochronous rings, using RF deflectors [1]. The preliminary phase of the CLIC Test Facility CTF3 [2] successfully demonstrated the feasibility of such a scheme at low charge [3]. A train of five pulses, produced by the source at the front-end and accelerated in a linac, was injected into an isochronous ring, using RF deflectors that create a time-dependent closed bump of the reference orbit and thereby allow the interleaving of the pulses at the injection. In this paper, we present a new method to monitor the bunch train combination, based on frequency spectrum analysis. When the first pulse is injected into the isochronous ring, the distance between two consecutive bunches is 10 cm, i.e. 333 ps. Therefore, all harmonics of 3 GHz can be found in the beam power spectrum. At the end of the bunch train combination, the distance between two consecutive bunches is reduced by a factor five. As a result, only the harmonics of 15 GHz should be found in the beam power spectrum (see Fig. 1). A coaxial pick-up and its read-out electronics were developed in order to extract the information contained in the beam. The bunch frequency monitor was installed and commissioned at CERN

during the last operating period of the CTF3 preliminary phase in 2002 [4]: a description of the measurements that were performed, as well as an analysis of the results that were obtained, are summarized in this paper.

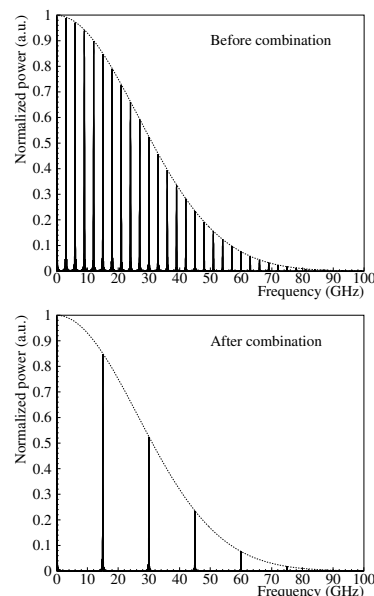

Figure 1: Calculated normalized power spectra for a train of gaussian bunches with a fwhm length of 10 ps before and after the bunch train combination with a factor five.

### DESIGN OF THE PICK-UP AND ITS READ-OUT ELECTRONICS

#### Description of the coaxial RF pick-up

The geometry of the extraction coaxial pick-up was chosen in order to include a miniature ultrahigh vacuum feedthrough [5] while meeting various technical constraints (see Fig. 2). This feedthrough can be considered as a two dielectric coaxial line, with a constant inner diameter of 0.4 mm. On the vacuum side, the inner conductor is maintained in its central position by a small ceramic ring. A hole of 1.5 mm diameter was drilled in the beam pipe wall for the extraction of the signal. On the other side, the feedthrough is terminated by a K connector. The geometry of the pick-up was included in MAFIA simulations [6] and its transfer impedance was derived for the five frequencies of interest (9, 12, 15, 18 and 21 GHz).

\* The research of A. Ferrari was supported by a Marie Curie Fellowship of the European Community Programme "Improving Human Research Potential and the Socio-economic Knowledge Base" under contract number HPMF-CT-2000-00865.

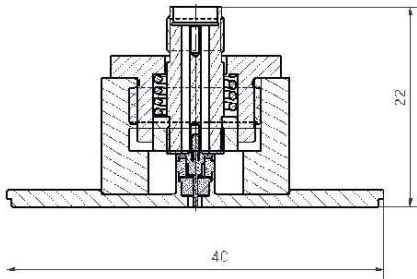

Figure 2: Technical drawing of the pick-up (the dimensions are in mm). The vacuum side is at the bottom of the figure.

*Description of the read-out electronics*

The signal coming from the pick-up is transported to the read-out electronics through a 50 Ω low loss SMA cable, on which a 6 dB attenuator is mounted in order to damp the possible multiple reflections between the pick-up and the input of the read-out electronics. The signal then goes through a wideband amplifier, a 10 dB attenuator, and a second low loss SMA cable. Afterwards, it is divided into five channels using two power splitters. Each channel consists of a bandpass filter to select the harmonic of interest, of a low noise amplifier, and of a diode used in the square law region to produce the envelope of the RF signal. After their extraction through SMA-BNC connectors, the signals are transferred to an oscilloscope for further analysis. The layout of the read-out electronics is shown in Fig. 3.

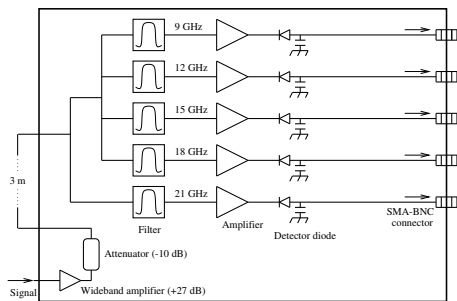

Figure 3: Schematic layout of the read-out electronics.

Before making measurements with beam, a calibration was performed to check the frequency response of the read-out electronics and to measure its amplitude response at each frequency of interest. When doing this, we noticed that the amplitude of the output signal on the oscilloscope was strongly dependent on the length of the RF pulse at the input of the read-out electronics. In particular, if the length of the input RF pulse is of the order of a few ns (which is the length of a bunch train in the CTF3 preliminary phase), the read-out electronics does not reach a steady state and the peak amplitude of the output signal is thus smaller than in the case of a long input RF pulse. An accurate calibration of the read-out electronics was therefore difficult, because of the uncertainties on the shape and the length of the bunch trains in the ring.

**COMMISSIONING WITH BEAM**

*Time domain measurements*

To visualize directly the time structure of the bunch trains in the ring, the pick-up signal was read directly on a 20 GHz sequential sampling oscilloscope. A high-quality trigger was given to this oscilloscope, which was running at a few Hz. Fig. 4 shows the waveforms measured just upstream of the wideband amplifier, before and after the bunch train combination with a factor five.

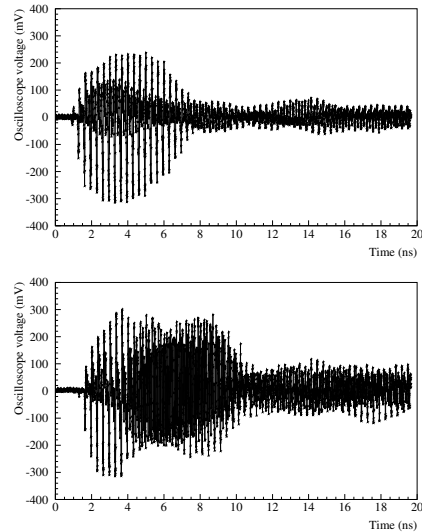

Figure 4: Time structure of the signal induced in the pick-up by the passage of a bunch train in the CTF3 ring, before (top) and after (bottom) combination.

Not only the signal produced by the 6-7 ns long bunch train is detected. Some reflections may occur in the pick-up itself but, most likely, some waveguide modes may be excited along the beam path and propagate together with the bunch train. Since these modes can be produced at many locations in the ring and since they have different velocities, some are detected at the same time as the bunch train, while others arrive up to tens of ns later. A Fourier Transform analysis of the time signal was performed at each step of the bunch train combination. As expected, only the harmonics of 3 GHz are found in the frequency spectrum and the power associated to 15 GHz increases while the bunch trains are combined. However, the repartition of the power between the various harmonics is not uniform along the bunch train. In particular, after the bunch train combination, only the core of the pulse has an almost pure 15 GHz structure, while all harmonics of 3 GHz can still be found at the edges of the pulse. The fact that the bunch trains do not perfectly overlap is the main reason for this effect. Finally, by treating separately the pulse and the tail, we noticed that the power spectrum of the signal induced by the wakefields contains the same harmonics as the signal induced by the bunches themselves, although not with the same amplitudes. For all harmonics, the power found in the

first 8 ns of the waveform is about one order of magnitude larger than the power found in the tail.

### Frequency domain measurements

To study the evolution of the beam frequency spectrum during the bunch train combination, the pick-up signal was filtered in the read-out electronics before analysis with a digital oscilloscope. When doing these measurements, the charge per bunch was found to be about 0.06 nC and the bunch length was measured between 7 and 12 ps fwhm. The beam transverse position at the location of the monitor was derived from measurements upstream and downstream of the pick-up: we found respectively  $-1.0 \pm 1.0$  mm and  $-1.6 \pm 0.8$  mm in the horizontal and vertical directions. MAFIA simulations were performed to estimate the power level induced by a 6.6 ns long RF pulse at the pick-up output in these experimental conditions, for each harmonic of interest and at each stage of the bunch train combination. An RF synthesizer driven by a DC pulse generator was used in order to inject 6.6 ns long RF signals in the read-out electronics, at each frequency of interest and with the power levels estimated with MAFIA. The output waveforms were then compared with the signals coming directly from the pick-up at each step of the bunch train combination, see Fig. 5. The distance between the pulses is 420 ns, which corresponds to the combiner ring circumference. At 15 GHz, the signal amplitude clearly increases each time a new bunch train is injected and, at the end of the bunch frequency multiplication, most of the power is found in the 15 GHz harmonic. However, other channels also receive some signal and there are a few discrepancies between the expected and measured signal amplitudes. This is probably due to the fact that the longitudinal overlap between the five bunch trains is not perfect (the bunch frequency multiplication mainly occurs in the core of the final pulse). Indeed, the signal pattern is not consistent with a systematic phase error at injection. Another reason may be the presence of wakeguide modes between the bunches: depending on their phase, they can induce either an increase or a decrease of the output signal amplitude.

## CONCLUSION

We have reported on the successful commissioning of a new instrument aimed at monitoring the combination of electron bunch trains in the combiner ring of the CTF3 preliminary phase, however with two limitations: the first one is the fact that the time extension of the bunch trains is smaller than the rise time of the read-out electronics, which makes it difficult to measure accurately the absolute power level contained in each harmonic (in the next stages of CTF3, the length of the bunch trains will be 130 ns). The second limitation is the presence of waveguide modes propagating in the beam pipe, in the wake of the electron bunches, and leading to a distortion of the signal coming from the monitor.

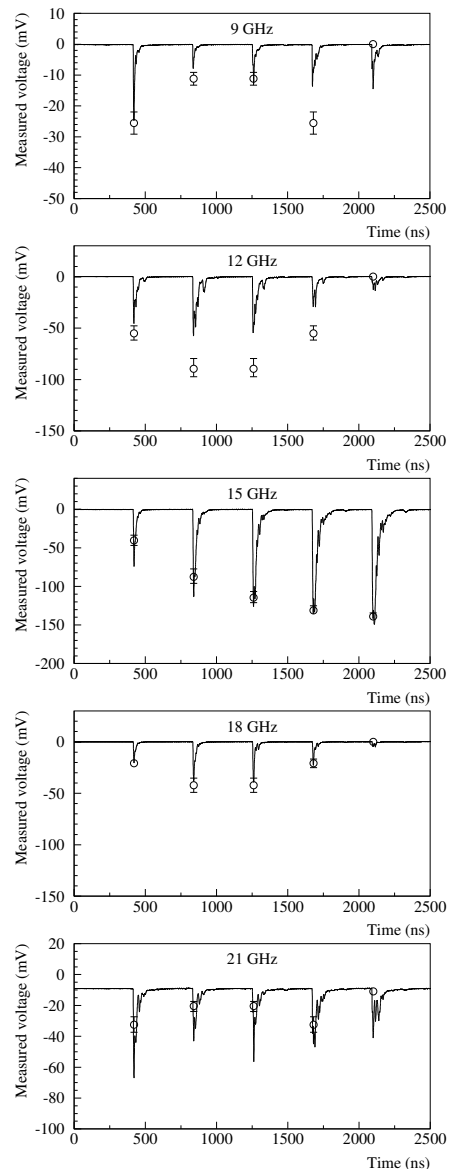

Figure 5: Bunch frequency monitor signals, while a bunch train combination with a factor five occurs: the open circles show the expected amplitude when combining trains of 20 bunches in the measured experimental conditions.

## REFERENCES

- [1] R. Corsini (Ed.) et al., CERN-99-06 (1999).
- [2] G. Geschonke (Ed.) et al., CERN/PS 2001-072.
- [3] C. Biscari, R. Corsini, A. Ferrari, A. Gallo, A. Ghigo, L. Rinolfi, P. Royer, F. Tecker, CTF3 note 054, CERN-AB note 2003-023.
- [4] F. Caspers, R. Corsini, A. Ferrari, L. Rinolfi, P. Royer, A. Rydberg, F. Tecker, CLIC note 557.
- [5] J. Durand, T. Tardy, R. Trabelsi, CERN-PS/LP/96-09 (tech), CERN-EST/96-03.
- [6] CST (Computer Simulation Technology), "Mafia Release 4.106", CST Darmstadt, Germany.