

# A NEW TRAJECTORY MEASUREMENT SYSTEM FOR THE CERN PROTON SYNCHROTRON \*

J.M. Belleman, CERN, Geneva, Switzerland

## Abstract

We describe the projected new trajectory measurement system for the CERN PS, currently under design, in which the trajectory of each particle bunch is calculated on the fly from a continuous high-rate stream of digitised PU signal samples. The system will store data for a full acceleration cycle. Multiple clients will then be able to select subsets of the data for further treatment and display.

Using a prototype of the projected hardware, raw PU signals have been accumulated during the 2004 run and processed off-line, validating the algorithms for beam synchronisation and calculation of trajectories for all current and known future beam types (subject to pick-up bandwidth limits) in the PS.

Records of the system behaviour, as implemented by the off-line processing chain and using real pre-recorded pick-up signals, will be shown.

## THE PS

The CERN Proton Synchrotron (PS) is the oldest particle accelerator still operating at CERN. It was commissioned in 1959 as the world's first alternating gradient, strong focusing machine. Still today, it is the kingpin of the CERN complex of accelerators, in which it now serves as the injector machine to the Super Proton Synchrotron (SPS). Today, the PS accelerates mainly protons ( $p^+$ ), but in the near future, it will also produce  $^{208}\text{Pb}^{54+}$  ions for LHC.

## PICK-UPS AND SIGNALS

The particle trajectories are measured with forty electrostatic pick-ups (PUs) distributed around the ring.

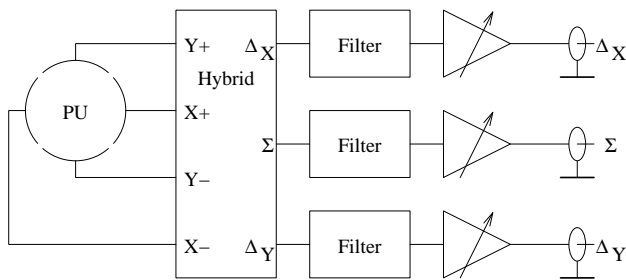

Fig 1 Pick-up analogue signal processing

\* We acknowledge the support of the European Community-Research Infrastructure Action under the FP6 "Structuring the European Research Area" programme (DIRAC secondary-Beams, contract number 515873)

Passive hybrids combine the electrode signals into a common sum ( $\Sigma$ ) and horizontal and vertical difference signals ( $\Delta_x$ ,  $\Delta_y$ ) (Fig 1). Pre-amplifiers installed near each PU shape and amplify the signals before they are carried over high-quality coaxial cable to the PS central building, where the signals are further treated. A VME-based computer controls the amplifier gains according to the expected beam intensity.

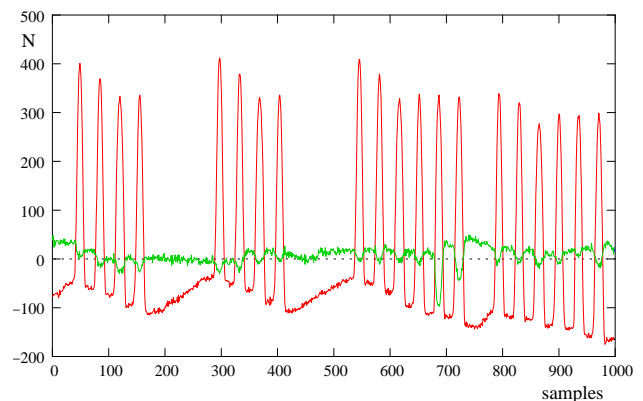

Fig 2 Example of PU signals: LHC beam at 2<sup>nd</sup> injection.  $\Sigma$  and  $\Delta_x$ .

The position of the centre of charge of a particle bunch is derived by integrating the three signals,  $\Sigma$ ,  $\Delta_x$ , and  $\Delta_y$ , over the length of a bunch, and normalising against  $\Sigma$ :

$$x = S_x \frac{\Delta_x}{\Sigma} + E_x \tag{1}$$

Here,  $S_x$  is a proportionality constant expressed in mm, and  $E_x$  is an additive error correction.

## Digital signal processing

The system digitises the analogue PU signals at a constant 125 Ms/s rate. The samples are pre-processed into per-bunch integrals on the fly before being stored in a memory big enough to hold the results for all bunches in the machine for the full duration of an acceleration cycle.

Given that different bunches may follow different trajectories, due, e.g., to being of different intensity, or to being injected at a different time, it is necessary to have a timing reference that can track each bunch from injection all the way through to ejection. The cavity RF is not suitable as a timing reference, because its phase with respect to the beam changes according to whether the beam is coasting or being accelerated, below or above  $\gamma$ -

transition. Also, due to cabling delays, the phase difference depends on  $F_{rev}$ .

Further complications are introduced by what are colloquially known as ‘RF gymnastics’. These consist of bunch splitting or merging and of changes in the bunch spacing other than through the effect of the changing revolution frequency [2][3].

A simple level trigger algorithm to detect bunch presence quickly runs into trouble because of varying filling patterns, bunch splitting and merging operations, different intensity bunches being accelerated together etc. Thus a more sophisticated approach is needed.

### Acceleration

Beams are injected at a magnetic field of 0.1T. Acceleration then takes place up to a maximum field of 1.26T. While  $p^+$  undergo only a small variation of  $F_{rev}$  when accelerated from 1.4 to 26 GeV, Pb ions have a variation of over one octave (Fig 3) [1].

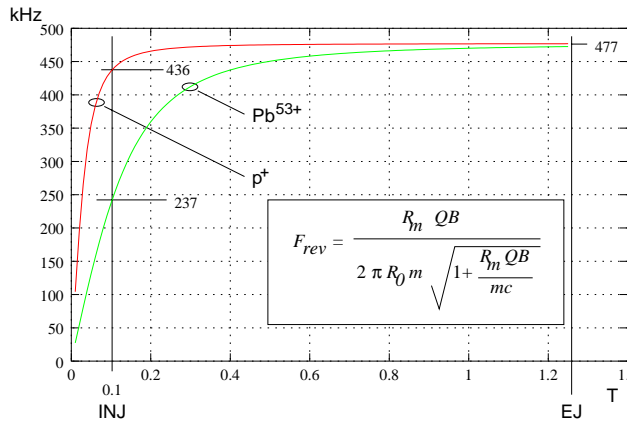

Fig 3 Revolution frequency vs. magnetic field

$R_m=70.0789$  m is the bending radius of the main magnet,  $R_0=100$  m is the machine radius,  $Q$  [C] is the particle charge,  $m$  [kg] the particle mass and  $B$  [T] the magnetic flux density. The peak  $dB/dt$  is about 2.3 T/s, yielding a peak  $dF/dt$  of 1.6 MHz/s near the start of acceleration.

### SYNCHRONISATION

The core of the synchronisation system is basically a numerical Phase Locked Loop (PLL) (Fig 4). A phase accumulator  $\theta$  is advanced by  $f$  every period of the sampling frequency  $F_s$ , making  $\theta$  overflow at the rate of  $F_{rev}$  (Fig 4). The phase accumulator output is used to address the phase table that contains  $h$  periods of the Local Oscillator (LO) signal. The LO frequency is thus  $h F_{rev}$ .

The LO is mixed with the incoming PU signal sample stream and the product is low-pass filtered to extract a phase error ( $\epsilon$ ). The phase error is fed back via a regulator to correct the value of  $f$ .

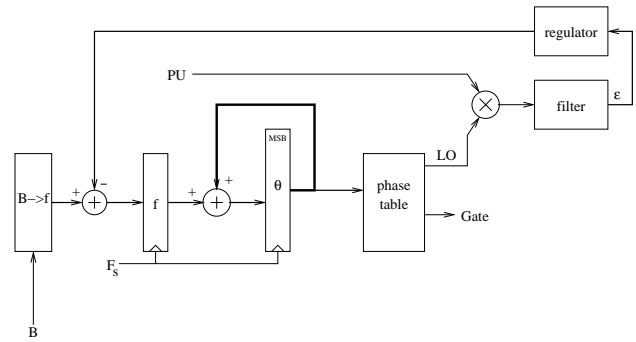

Fig 4 Principle of reference frequency generation

The value of  $f$  represents the value of the revolution frequency  $F_{rev}$  according to:

$$f = \frac{A F_{rev}}{F_s} \quad (2)$$

Here  $A$  is the full-scale value of the phase accumulator. A suitable initial value for  $f$  is provided by the block labelled  $B \rightarrow f$  according to Fig 3 and (2). The regulator keeps the phase relation between the PU and LO signals, and consequently the phase accumulator, constant.

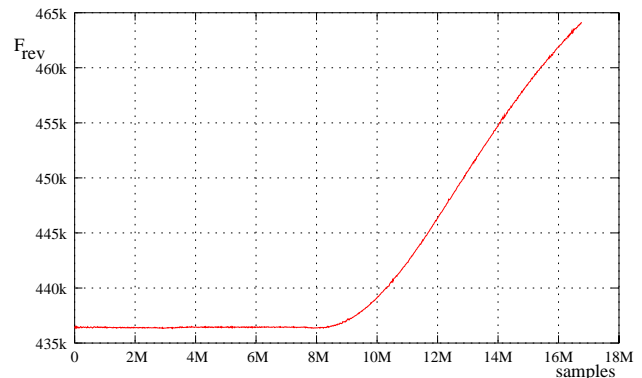

Fig 5  $F_{rev}$  as reconstructed by the PLL

Another column of the phase table is used to produce a ‘gate’ signal, delimiting the subsets of the PU sample stream that contain a bunch. These samples are added together to get an estimate of the integral over the bunch length, and the results are stored into memory at the end of each bunch.

The actual position calculation (1) can be deferred until data are requested for display on an operator console.

### Loop dynamics

The synchronisation loop is a discrete-time feedback system. Its transfer function can be expressed as polynomials in the ‘ $z$ ’ domain. The open-loop transfer function is:

$$H_o = \frac{hz^{-1}}{A(1-z^{-1})} \cdot H_m \cdot \left( \frac{z^{-1}}{1-0.996z^{-1}} \right)^3 \cdot \frac{(1-0.999z^{-1})^2}{1-z^{-1}} \cdot z^{-n} \quad (3)$$

The first factor represents the phase accumulator, modelled as an integrator. Here,  $A$  is the full-scale value

of the phase accumulator and  $h$  is the accelerator harmonic number.  $H_m$  is the mixer, modelled as a pure gain, usually of the order of a few hundreds.

The next factor is a low-pass filter that keeps only the low frequency terms of the phase error. Its corner frequency is a compromise between rejection of  $F_{rev}$  and loop settling time.

The fourth factor is the feedback regulator, starting with a pole at +1, i.e., an integrator, to make the static phase error tend to nought. Two real zeroes are needed to make the loop stable. Finally, the last factor,  $z^{-n}$ , represents the inevitable pipeline delays of the physical implementation of the loop ( $n \approx 6$ ).

The closed-loop transfer function is:

$$H_c = \frac{H_o}{1 + K_R H_o} \quad (4)$$

$K_R$  is the regulator gain. The stability of the loop can be assessed by examining the root-locus of  $H_c$  with the regulator gain  $K_R$  as the independent variable. All poles must lie within the unit circle. The optimal setting of  $K_R$  depends on the beam intensity and on  $h$ , the harmonic number. The loop behaves acceptably over a variation of  $K_R$  of more than 20dB.

The algorithm was tested by implementing it in the C-language and feeding it the raw data recorded using the prototype acquisition hardware.

### Handling RF gymnastics

For some types of cycle, the beam undergoes manipulations that change the number of bunches, or that change the spacing between them [2][3]. Typically, these operations span several tens of ms on a constant energy plateau. An example is the triple splitting of LHC bunches (Fig 6).

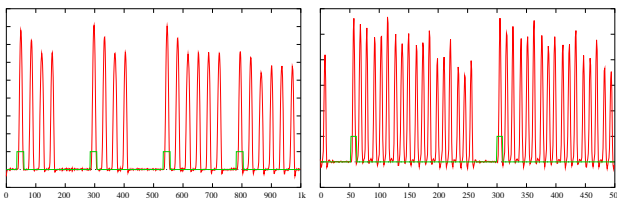

Fig 6 Beam and derived Gate signals before and after LHC triple split

These operations can be dealt with by switching to different phase table columns for the LO and Gate signals at an appropriate instant, e.g., at the end of a splitting operation. The PS machine timing system provides signals suitable for this use. By appropriately initialising the phase table contents beforehand, the change can be made without discontinuity.

### Resolution

The position resolution of the system has been estimated by gathering some statistics on position measurements at a quiet spot in an EASTB cycle (single bunch,  $10^{11} p^+$ ) (Fig 7). The true beam position was assumed not to vary over this roughly 250-turn interval.

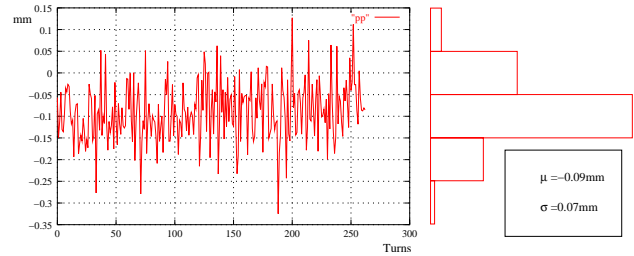

Fig 7 Positions and histogram over 250 turns on EASTB

The RMS resolution is slightly better than 0.1mm. However, the resolution deteriorates on cycles with shorter bunches. This issue remains to be examined in more detail.

### CONCLUSIONS

An entirely digital processing algorithm for trajectory measurement of individual bunches in proton synchrotrons, using fast constant-rate digitisers, is described. A C-program, reading real digitised PU data, was used to validate the algorithm off-line. It remains to be implemented in the form of FPGA logic. The design is sufficiently flexible to follow all present and known future RF gymnastics in the PS. The same design has been shown to be usable for other  $p^+$  or ion synchrotrons, such as the GSI SIS18 and the future GSI SIS100.

### ACKNOWLEDGEMENTS

Space here does not allow me to give proper credit where due, but I'd like to thank J.L. Vallet for explaining to me the intricacies of RF gymnastics, M. Gasior for the many discussions on the subject of feedback control and the GSI crew for their help in acquiring PU signals on the SIS18.

### REFERENCES

- [1] H.H. Umstätter, "Tables of dynamic parameters of the PS", CERN-MPS-Int-SR 68-7, 1968
- [2] R. Garoby, S. Hancock, A. Ozturk, J-C. Perrier, J-L. Vallet, "PS machine development report: Preparation of the nominal production beam for the AD", [PS/RF/Note 99-01 \(MD\)](#)
- [3] R. Garoby, S. Hancock, J-L. Vallet, "Demonstration of bunch triple splitting in the CERN PS", [CERN/PS 2000-038 \(RF\)](#)