

UPGRADE OF THE ISIS MAIN MAGNET POWER SUPPLY

J.W. Gray, W.A. Morris, Rutherford Appleton Laboratory Chilton Didcot Oxon OX11 0QX UK

Abstract

ISIS, situated at the Rutherford Appleton Laboratory (RAL) is the world's most powerful pulsed neutron source. Intense bursts of neutrons are produced every 20ms, when a heavy metal target is bombarded with a beam of high energy, 800 MeV, protons from a synchrotron. On the ISIS synchrotron the dipoles, doublet quadrupoles and singlet quadrupole magnets are connected in series using a configuration known as the "White circuit" [1]. The circuit uses a large, 1MJ, energy storage choke together with capacitor banks operated at the resonant frequency of 50 Hz, to reduce the reactive load on the AC make up supply. The series connection also has the advantage of ensuring that the same current, leakage current excepted, flows in all the magnets. A DC supply is used to bias the sinusoidal magnet waveform. Most of the power supply components were manufactured in the 1960's and are reaching the end of their design life. This paper discusses the issues involved in upgrading a central part of a facility, which is in continual use, without significantly affecting the users. Consideration is given to reducing the risk of extended down times resulting from the failure of major components. At the same time, ways of improving performance, by reducing losses and modifying the magnet current waveform are being actively sought.

1 INTRODUCTION

Any refurbishment of the Main Magnet Power Supply will have to be accomplished with as little disruption to the operation of the ISIS facility as is possible. A radical change in the power supply philosophy amounts to an extended shutdown whilst the old power supplies are removed and new ones are installed and commissioned. This study has therefore constrained itself to continuing with the "White Circuit" design, see Fig. 1, and hence considering only the possible replacement of the individual power supply components. Three criteria were considered important.

1. Where possible, the new power supplies should be installed and partially commissioned whilst ISIS is operating normally. During a planned shutdown, the cables can then be transferred from the old power supplies to the new, with a minimum of disruption.

2. Where possible, the new power supplies should include either an installed spare or locally available spare parts, to minimise the system unavailability in the event of a component failure.

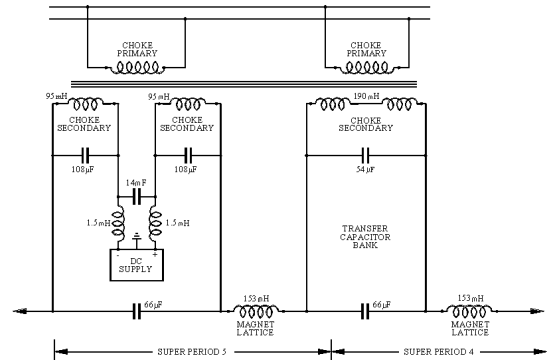

Fig.1 "White Circuit" Power Supply Configuration

3. Where possible, the new power supplies should allow for change to the magnet current waveform, to enable increased or modified performance to be introduced at a later date.

2 TRANSFER CAPACITOR BANKS

The original capacitor bank was obtained second hand from an earlier synchrotron experiment, NINA, at the Daresbury Laboratory. The capacitor bank is in ten sections, corresponding to the super-periodicity of the ISIS synchrotron and is installed in its own building. An important feature of the design of the capacitor bank is the ability to trim the capacitance of each section and hence adjust the resonant frequency of each part of the "White Circuit".

Although some of the capacitors originally contained PCB dielectric oil, these have already been replaced. The failure rate of the capacitors is not a problem and finding replacement capacitors is quite straightforward. However, an inquiry to a capacitor manufacturer has indicated that the space requirements for a new capacitor bank are much reduced from the original.

3 ENERGY STORAGE CHOKE

The energy storage choke, also ex-NINA, was manufactured in the early 1960's, see Fig. 2. The choke consists of ten interleaved primary and secondary windings. One of the secondary windings is split at its centre point to allow the insertion of the DC bias power supply and to define the earth potential of the system. The primary windings are all connected in parallel and form a close-coupled circuit with each resonant circuit. This coupling method reduces the leakage inductance and stray magnetic fields and ensures that each secondary circuit has the same frequency and phase relationship. The primary windings also provide the insertion point for the

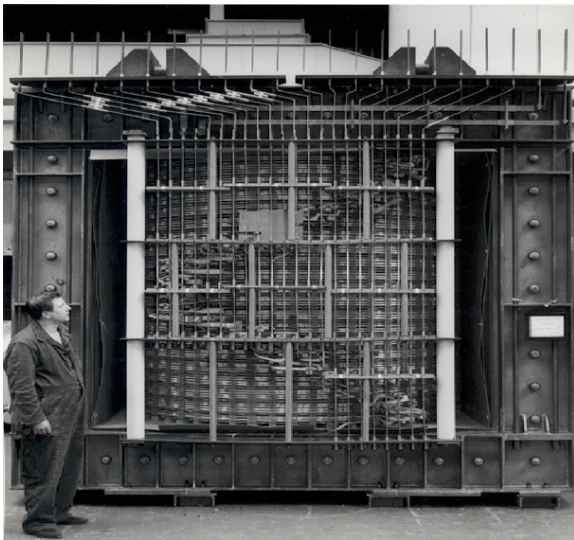

Fig. 2. Existing Storage Choke (during manufacture)

alternator power supply. This power supply makes up the AC losses and provides the frequency standard. The turns-ratio of the primary to secondary windings is 1:4. The rated secondary AC rms. Voltage is 14.4kV at 1022A. The nominal peak energy stored is 0.99MJ, 310MVA. The choke windings and core weigh 90 tonnes and has a total weight of 120 tonnes, when contained in its oil tank.

The choke is a major cause for concern regarding the reliability of the system. Although it has not been a problem in its thirty years of continuous service, the state of the insulation is not known. The tank leaks oil and as this is continuously being replaced, it is not possible to monitor any deterioration of the insulation system. Should the choke fail, the ISIS facility is likely to be down for at least one year whilst the choke is removed, repaired and

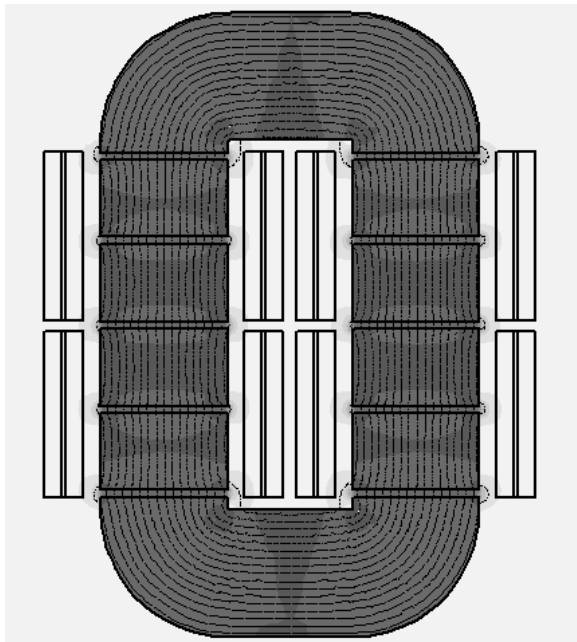

Fig. 3. Magnetic fields from a dual winding storage choke: Total Excitation 288kAt. Max. Field 1.9T.

replaced. The planned replacement of the choke is therefore an urgent priority.

A design study has considered replacing the single choke, with ten secondary windings, by five smaller chokes, with two secondary windings each. To preserve symmetry, each winding is manufactured in two sections. The manufacturing complexity of the device is reduced and it also becomes a viable option to purchase a spare unit. One of the two windings would be manufactured in two sections. This would allow the insertion of the DC Magnet Bias Power Supply on one transformer only, the other four transformers would have this connection linked out.

The study has revealed that it is feasible to use a multiple air-gapped "C" core wound magnetic circuit and that stray magnetic fields in the winding region can be reduced to the point where solid conductors can be used without incurring large eddy current losses in the copper. Each air gap is screened by a winding so external stray fields are kept low. Fig. 3 shows the level of magnetic fields in the vicinity of the choke.

4 AC EXCITATION AND MAKE-UP LOSSES POWER SUPPLY

The AC Excitation and Make-up Power Supply comprises a single phase AC generator driven by a DC motor, see Fig. 4. In addition to the rotating machinery, there are also two other important controlling power supplies: two 400kW series connected AC to DC converters, which provide the make-up losses, and the alternator rotor excitation supply

The original power supply tender request produced a nil return. It was considered to be too difficult. The power supply, which was then procured piece-meal, using equipment that could be readily obtained is far from an optimum

Single phase AC Generator and Drive Motor

A three-phase alternator was eventually purchased second hand and was modified to give satisfactory performance as a single-phase machine. Procurement was difficult because most alternators are designed for operation with a steam turbine running at 3000 rpm, and the requirement was to feed the generator from a DC motor running at 1000 rpm. The alternator was rated at 5kV rms., 50Hz single phase, 1060kVA and 1000 rpm.

Initial problems with excessive heating in the damping windings were overcome by increasing the amount of copper. The single-phase operation of the generator has also resulted in increased vibration levels. These take their toll on the generator bearings, reducing their operational life.

Had the technology of inverter power supplies been more advanced in 1980, the purchase of both an alternator and a DC drive motor could have been avoided. A 50Hz

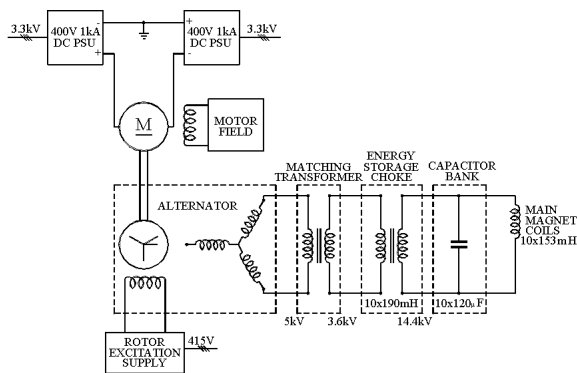

Fig 4. Excitation and Make-up Losses Power Supply

thyristor-controlled inverter locked either to the mains supply frequency or its own standard, would then have directly fed the primary windings of the Energy Storage Choke. This approach is the basis for the philosophy of the power supply upgrade.

400kW AC to DC Converters

Two 400kW AC to DC Converters are connected in series to provide a nominal 800V at 1kA. The mid-point of the supply is grounded. The power supplies contain a 3.3kV / 360V, Delta / Delta 511kVA, air natural cooled, Class "C" insulation, transformer. The power supplies were part of a series of controlled units with outputs ranging from 50kW to 1.2MW for use with the magnets on the NIMROD machine. The power supplies have operated reliably and breakdown maintenance is accomplished within a few hours. However, very few spares now exist. The power and control electronics is now obsolete and circuitry should be replaced. However, since the upgrade will take much longer than the time allocated for a standard shutdown, it has never achieved a high priority.

5 DC MAGNET BIAS POWER SUPPLY

The DC Magnet Bias Power Supply was manufactured in 1980. It was supplied as a complete system including output filter components. The nominal ratings are 700A supplied at 1540V. The power supply provides only the DC component of the magnet current, the AC path is provided by a 14mF capacitor bank. Two 1.5mH chokes isolate the AC path from the DC power supply. Other filter components enable an earth connection to be made to the power supply, so that the output becomes in effect a bipolar supply. The power and control electronics of this power supply are also obsolete.

6 DISCUSSION

The Main Magnet Power Supply is, on the whole, a reliable system. However, it is an old system and is near the end of its maintainable life. In particular, the state of the Energy Storage Choke is not quantifiable. The

downtime associated with the failure of some of the power supply components is unacceptable from an Operations' point of view. In particular, the downtime associated with a failure of the Energy Storage Choke is in excess of 12 months.

It is considered that the whole power supply has a real probability of a catastrophic failure, and should be replaced in an orderly manner that will minimise the effect on the operation of the ISIS facility, before any such failure causes a major shutdown.

One scenario would be to construct a new Power Supplies Building, install the new plant and then after the plant has been functionally tested, effect a orderly transfer from the old to the new. However, space in the vicinity of ISIS is already at a premium and an extension to the existing rotating plant room would be difficult to achieve without making the storage choke totally inaccessible. The failure of the choke during the construction period would be acutely embarrassing and its removal at a later date would be almost impossible.

A new capacitor bank would occupy less space in the Capacitor Bank Building, than do three of the ten existing capacitor banks. If these capacitors were to be replaced at the start of the refurbishment programme, valuable space would be released to allow the installation and commissioning of other power supplies. This action would release about 75% of the original enclosure, i.e. ~350m². A preliminary study has shown that this space should be adequate for the installation of replacement power supplies, which can then be installed without disrupting the facility operation.

If the system voltages, etc, of the replacement power supplies are specified to be identical to that of the existing plant, the changeover between the two systems can be on a piece-meal basis, as each component piece is commissioned.

7 CONCLUSION

We believe that a way forward has been found that will allow the replacement of the whole of the ISIS Main Magnet Power Supply in an orderly manner without drastically reducing the availability of the facility. Only the first stage: the replacement of the ten resonant capacitor banks needs to be completed within a maintenance shutdown period. Other systems can be installed without interference to the Operational Cycle and then a change over effected during the shutdown.

REFERENCES

- [1] M.G. White et al., "A 3-BeV High Intensity Proton Synchrotron", The Princeton-Pennsylvania Accelerator, CERN Symp.1956 Proc., p525.