

LAE 10 ELECTRON ACCELERATOR CHARGE MONITOR

Z. Dźwigalski, Z. Zimek, Department of Radiation Chemistry and Technology,
 Institute of Nuclear Chemistry and Technology, Warsaw, Poland, e-mail: dzwigal@orange.waw.pl

Abstract

A non-destructive beam-charge monitor which measures the charge in single pulses of accelerated electrons in range from 1 nC to 15 nC is described. The device is used in nanosecond pulse radiolysis experiments for recording pulse-to-pulse fluctuations of dose rate in the target cell. The calibration of the induction monitor circuit was verified by measurement performed with Faraday cup and digital oscilloscope.

1 INTRODUCTION

The measuring system of charge of single nanosecond pulses of accelerated electrons for pulse radiolysis experiments has been described. The absorbed dose in irradiated object is proportional to the time duration and beam current level, i.e. to the total charge of accelerator electrons within the pulse. The total charge of electrons Q is equal to:

$$Q = \int_{t_1}^{t_2} I_b(t) dt \quad (1)$$

where: $I_b(t)$ – beam current; $t_2 - t_1$ - pulse duration

The total charge within the pulse can be measured by induction monitor, secondary electron monitor or Faraday cup. The induction monitors are used most frequently in pulse radiolysis experiment [1-3] because this method does not interfere in electron beam distribution. The

results of tests of induction monitor developed in INCT has been described. The induction monitor has been calibrated by Faraday cup and digital oscilloscope measurements.

2 EXPERIMENTAL TEST OF INDUCTION MONITOR AND MEASURING SET UP

The induction monitor is composed of the resonance circuit (frequency 20 kHz) and simple peak detector equipped with active filter. The schematic diagram is shown in figure 1.

The coil main element of the circuit is made of ring type ferrite with inside diameter $d=108$ mm. The coil plays the role of secondary winding of the current transformer in which the primary winding is the beam current. If the resonant circuit losses are small and pulse duration is much smaller than the coil oscillation period the amplitude measured by monitor is proportional to the charge of electrons [1]. Amplifier circuit is apply (x 200) to increase voltage from tens of mV to several volts level. The output voltage is practically kept constant in time $t \leq 2$ s which is needed to transfer the data to computer.

The block diagram of the testing circuit is shown on figure 2. The electron beam was replaced by the wire which is connected to programmable square wave generator type 8600 (output amplitude $I=0.01$ A). Suitable charge was selected by pulse duration change in the range from 100 ns to 1500 ns.

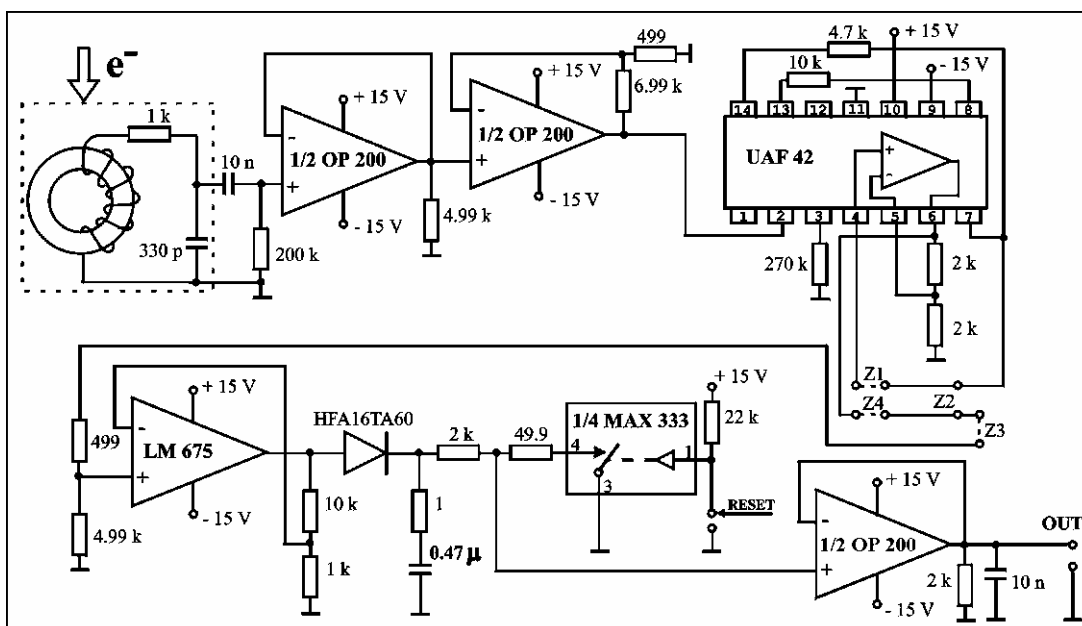

Figure 1: Charge monitor circuit diagram.

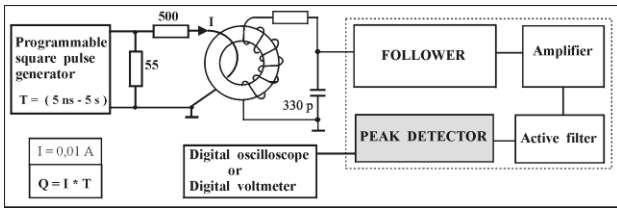

Figure 2: Calibration circuit diagram of the charge monitor.

The output signal was register on TDS 620 digital oscilloscope and digital camera type Q 100 C or digital voltmeter YF – 78 type.

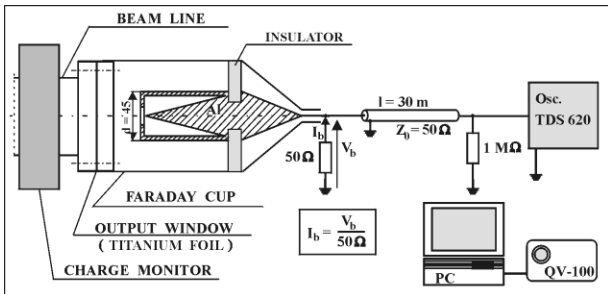

Figure 3: Calibration test circuit diagram of the charge monitor.

The calibration of the monitor circuit was verified by measurement performed with Faraday cup, digital oscilloscope and photo camera. The simplified diagram of measuring circuit is shown on figure 3. It can be added that the digital oscilloscope allows to measure automatically the charge within the pulse. Registered signal is proportional to the current I_b (voltage drop on 50Ω resistor).

It can be mentioned that the induction monitor was placed on the same position during test and calibration procedures.

3 RESULTS

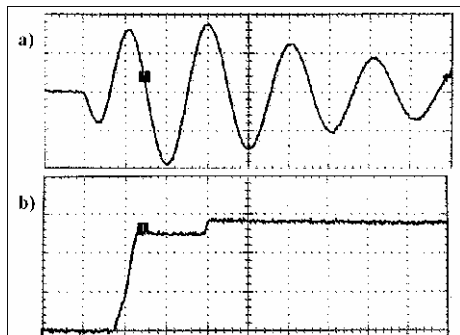

Figure 4: Exemplary pulses oscillograms (time scale, $25 \mu s / div$).

a) The shape of the oscillations before the peak detector diode (vertical sensitivity, $2 V / div$);
 b) initial pulse part on the monitor output (vertical sensitivity, $1 V / div$).

Figure 4 shows selected pulses registered in two different parts of the monitor. Upper picture shows the oscillation registered on the output of LM 675 amplifier, just before UAF 42 active filter and before diode detector. The oscillation period is $50 \mu s$. The lower picture shows the initial part of the output signal which is identical to voltage detected on capacitor $0.47 \mu F$ of peak detector. It can be noticed the capacitor is charged in two steps what corresponds to the amplitude of oscillation on upper picture.

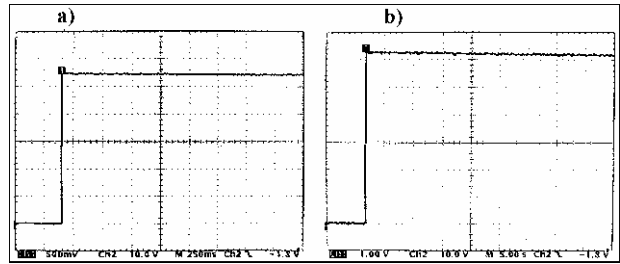

Figure 5: Progress of the signals on the monitor output.

a) For standard charge $2.5 nC$ and time base $250ms / div$;

b) for standard charge $2.5 nC$ and time base $5 sek / div$.

Figure 5 shows the induction monitor output signals in larger time scale, $250 ms / div$ and standard charge $2.5 nC$ (figure 5a) and standard charge $10 nC$ and time scale $5 s / div$ (figure 6b). It can be noticed that voltage drop after $2 s$ is small. It was found by digital voltage measurement, that the voltage drop after $5 s$ is not higher than 0.25% in the range $2.5-15 nC$. Voltage drop for the range $1-2.5 nC$ is lower that $3mV/s$ what is similar to the sampling and hold circuit parameters.

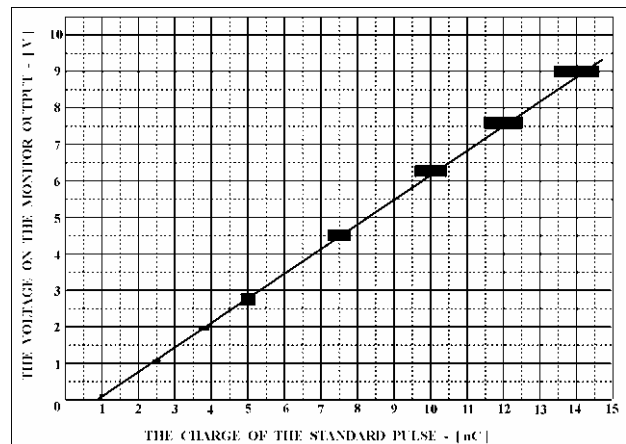

Figure 6: The curve of the monitor calibration.

The calibration curve is presented on figure 6. It can be noticed that linear relation between output signal and measured charge within the pulse is observed. Sensitivity of the induction monitor has been found – $0.7 V / nC$.

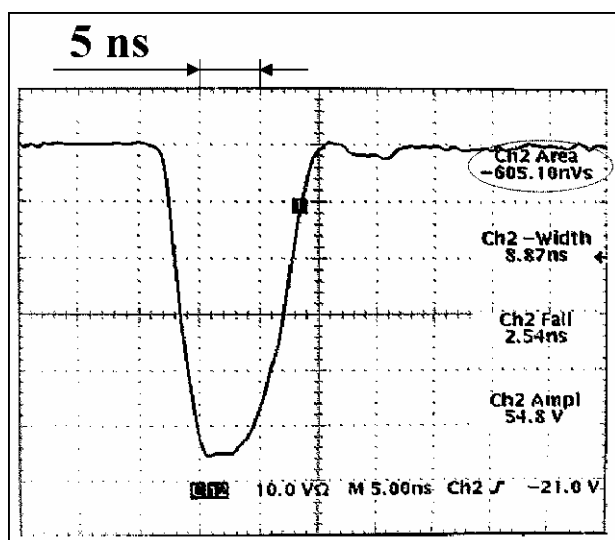

Figure 7: LAE 10 electrons pulse shape.

The simultaneous charge measurements were performed by induction monitor and Faraday cup. The surface field limited by shape of pulse curve and time axis is marked on figure 7. The surface field is proportional to the charge of the electrons pulse.

The sources of measurement errors are certain instruments (digital oscilloscope, digital voltmeter and

pulse generator). It is also concern to induction monitor and particularly method of charge measurements. It can be assumed that when the RLC circuit losses are small and period of oscillation is much higher than pulse duration, the error connected to U_{Cmax} voltage can be evaluated as:

$$\Delta = 0.1667 * f^2 * \tau^2 * 10^3 \text{ [%]} \quad (2)$$

where: f – RLC circuit resonance frequency;
 τ – pulse duration of electrons.

The digital oscilloscope error (Tektronix TDS 620) is $\pm 2\%$. The digital voltmeter error (multimeter YF-78) in the range 20 V (sensitivity 10 mV) is $(0.5 \% + 3 \text{ "digit"}) = \pm 0.13 \text{ V}$, in the range 2 V (sensitivity 1 mV) is $(0.5 \% + 3 \text{ "digit"}) = \pm 0.013 \text{ V}$, and in the range 0.2 V (sensitivity 0.1 mV) is $(0.5 \% + 1 \text{ "digit"}) = \pm 0.0011 \text{ V}$. Pulse generator error (Tabor Electronics firm type 8600) is $\pm 2 \%$ ($\pm 20 \text{ mV}$) for the pulse amplitude and ($\pm 1 \% \pm 0.2 \text{ ns}$) due to time duration.

The induction monitor circuit error can be evaluated according to date given in Table 1. The linearity of the induction monitor in one week time was not worst than $\pm 1 \%$. It is mostly due to very good performance of the operational amplifier type OP 200 which is used on the input of the circuit.

Table 1. Induction monitor circuit errors.

Parameter		OP 200	UAF 42	LM 675
Input Offset Voltage	[mV]	Max. 0,075	Typ $\pm 0,5$	1
Offset Voltage Drift	[$\mu\text{V} / ^\circ\text{C}$]	Max. 0,5	3	25
Long Term Input Voltage Stability	[$\mu\text{V} / \text{month}$]	Typ 0,1	several	
Power Supply Rejection Ratio	[$\mu\text{V} / \text{V}$]	Max. 1,8	10 -100	

4 FINAL REMARKS

The described induction monitor is applied to measure the charge of single electron beam pulses within the range 1–15 nC and pulse duration 1–1500 ns. The measuring error does not exceed 6 %. The output voltage drop is very small in spite that the sampling and hold circuit has not been applied.

5 REFERENCES

[1] R. Steiner, K. Merle and H. G. Andersen, Nucl. Instrum. Meth. 127, 1975, pp.11-15
 [2] Z. Zimek, Radiat. Phys. Chem. 11, 1978, pp.179-181
 [3] B. Vojnovic, Gray Laboratory Research Trust Annual Report 5, 1997, Northwood, UK