

BEAM LOSS MONITOR FOR UNDULATORS IN PAL-XFEL*

H. Yang[†] and D. C. Shin
 Pohang Accelerator Laboratory, Pohang 790-784, Korea

Abstract

PAL-XFEL consists of a hard x-ray line, based on a 4-10-GeV electron beam, and a soft x-ray line, based on a 3-3.5 GeV electron beam. The HX line consists of 20 undulators and the SX line consists of 7 undulators. The permanent magnets in an undulator should be protected from the radiation-induced demagnetization. We develop a beam loss monitor (BLM) for undulators in PAL-XFEL. It consists of a detector part (head) and an ADC part. The BLM head consists of two fused quartz rods, two photo-multiplier tube (PMT) modules, and an LED bulb. It is based on the Cherenkov radiator: two fused quartz rods are used for radiators. Two sets of the radiator and PMT module are installed up and down the beam tube. An LED bulb is between the radiators for the heartbeat signal. The ADC part digitizes the output signal of the PMT module. It measures and calculates the beam loss, background, and heartbeat. One ADC processes the signal from 6-8 heads. The BLM system generates interlock to the machine interlock system for over-threshold beam loss. The 28 BLM heads are installed downstream of each undulator. Those are calibrated by the heartbeat signal and operated in the electron beam transmission with 150 pC.

INTRODUCTION

PAL-XFEL produces 0.1 – 1 nm FEL with 4 – 10 GeV electron beam in the hard x-ray (HX) line and 1–10 nm FEL with 3 – 3.5 GeV electron beam in soft x-ray (SX) line. 20 and 7 undulators are installed respectively in the HX line and the SX line. Undulators made with permanent magnets are used for the FEL generation in the XFEL machines [1-3]. Since there is the radiation-induced demagnetization for the permanent magnet, it is important to prevent the electron beam irradiation in the undulator [4]. This irradiation is occurred unintentionally by the electron beam loss in the undulator region caused by abnormal beam orbit and beam size. The beam operation should be blocked until the system is recovered in the normal condition.

We develop the SLAC type Beam Loss Monitor (BLM) system for interlock of the undulator region [5]. The system consists of the BLM head (detector part) and the ADC part. The BLM heads are based on Cherenkov radiators. They are installed after each undulator and measure the beam loss occurred at the drift in each undulator. The beam loss signal is digitized in the ADC system. It calculates the beam loss and generates interlock signal for over threshold beam loss. In this paper, we present the design of the BLM head and ADC system. Also, we present the details of the installation, calibration, and operation of this system.

* work supported by MSIP, Korea.

† highlong@postech.ac.kr

BLM HEAD

The BLM head converts Cherenkov radiation by the electron loss into electric signal. It is located in the 1-m long intersection of the undulator region (Fig. 1(a)). It consists of radiators, PMT modules, an LED bulb, and a case (Fig. 2). The radiators are located at up and down of the beam tube (Fig. 1(b)) and the PMT should receive photons from two radiators. Since the width of the BLM head should be minimized for installation of other components in the intersection, we used two PMT modules with small size for each radiator.

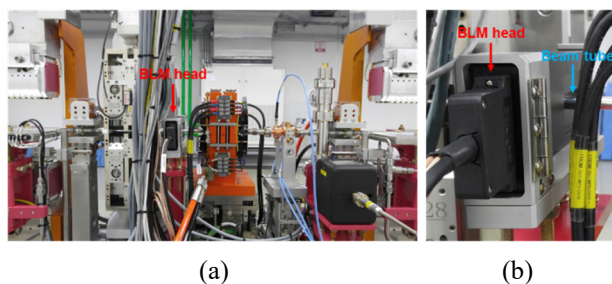

Figure 1: (a) Location of the BLM head at the intersection in the undulator region. (b) Location of the BLM head and the beam tube.

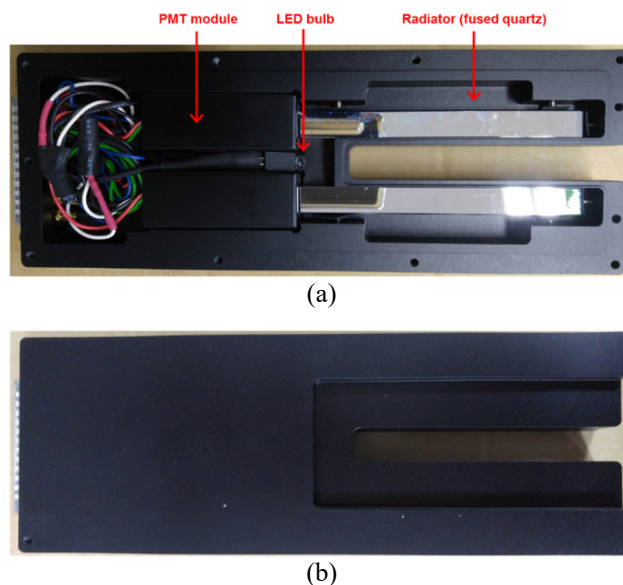

Figure 2: Structure of (a) the inside and (b) the back of the BLM head.

Content from this work may be used under the terms of the CC BY 3.0 licence (© 2018). Any distribution of this work must maintain attribution to the author(s), title of the work, publisher, and DOI.

The model of the PMT module is Hamamatsu H10722-110. It has 230 – 700-nm spectral response range, 1-V/ μ A conversion factor at 1-V control voltage, and 8-mm-diameter effective area. The radiators are the fused quartz rods with 11-mm \times 11-mm \times 110-mm size (Fig. 3). When the lost electrons enter the radiator, the Cherenkov radiation is emitted in random direction along the incidence angle of electrons. In order to transmit the radiation to the PMT with less loss, a pure aluminium film was coated onto 5 faces of the radiators for the reflector and an AR coating layer with 400 – 500-nm penetration wavelength was coated in the face to meet the PMT module for more penetration of light (Fig. 3). The additional AR coating layer was coated in the corner of one longer face for penetration of light from the LED bulb (Fig. 3).

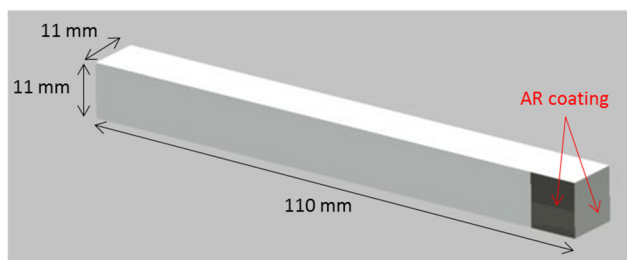

Figure 3: Drawing of the fused quartz rod.

The LED bulb with 5-mm diameter and 480 – 520-nm wavelength is for the heartbeat signal. It checks operation of the PMT module by its pulsed operation after electron beam time. The case is a rectangular shape with 24.7-mm \times 85-mm \times 236-mm size, and made of aluminium. There is a groove with 13-mm height and 105-mm length for the beam tube (Fig. 2). Since the inner area of the BLM head should be darkroom to reduce the background noise of PMT, the surface of case was anodized (Fig. 2). The empty space in the back of the BLM head (Fig. 2(b)) is for installation of other material with upper atomic number than aluminium. Since it makes more secondary electrons for lost electrons, the measuring resolution of the beam loss can be improved.

ADC SYSTEM

ADC system for BLM is divided into the power unit and the VME system (Fig. 4). The power unit consists of the Single Board Computer (SBC), FPGA, 16-channel DAC, and power module (Fig. 5). The SBC with EPIC IOC controls digital/analogue signal, FPGA, and the data acquisition. The FPGA generate the heartbeat signal from the input trigger. It has 8-output channels. PMT gain voltage is controlled 0.1 – 1.1 V by the 16-channel DAC.

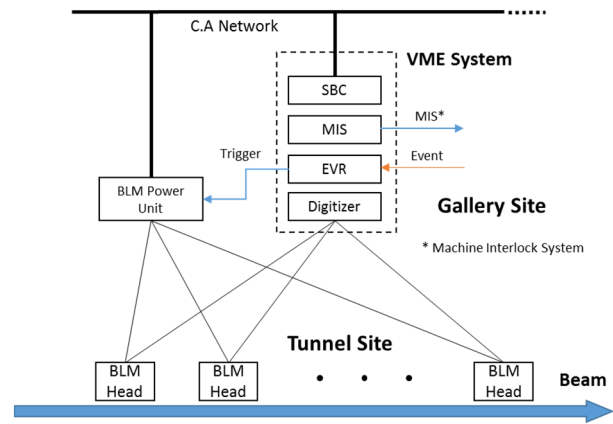

Figure 4: ADC system for the BLM.

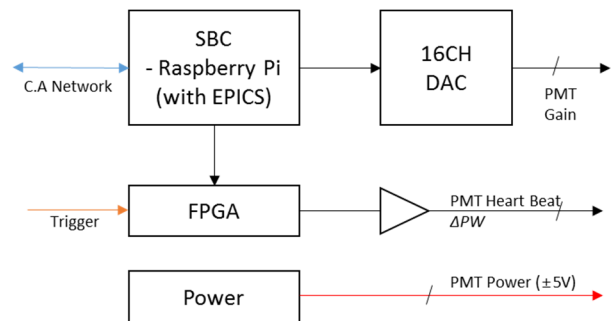

Figure 5: Power unit for the ADC system.

The VME system consists of the digitizer, Event Receiver (EVR), SBC, and Machine Interlock System (MIS) card (Fig. 6). The digitizer has 14-bit resolution and \pm 5-V input voltage range. We can switch its sampling frequency with 0.78, 1.56, 3.125, 6.25, 12.5, 25, 50, and 100 MS/s. We use 0.78 MS/s in the BLM operation and the one-time unit for the AD is about 1.28 μ s. The EVR receive the event data from the Event Generator (EVG) and generates the trigger and event cord for the BLM system. The MIS card link the BLM to MIS system. When the beam loss over the threshold is occurred, the MIS card send the interlock signal and the MIS system block the laser shutter in the electron gun. The details of devices for the ADC system is shown in Table 1.

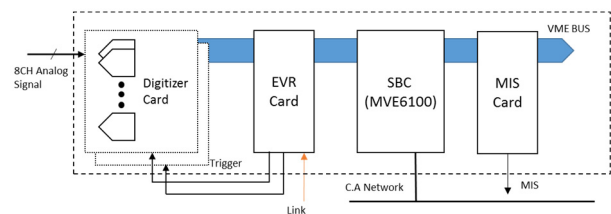

Figure 6: VME system for the ADC system.

Table 1: The Details of Devices for the VME System

Device	Specification
SBC	Raspberry Pi, Linux OS, with EPICS IOC
FPGA	8-channel output
DAC	16-channel output
Power module	PMC15E-3 (COSEL)
Digitizer	V1724 (CAEN), 14bit, +/-5V, 8 S/F (MS/s) (0.78, 1.56, 3.125, 6.25, 12.5, 25, 50, 100)
EVR	for event trigger and cord
SBC	EMVME6100 (EMERSON)
MIS card	8-channel output, self-development

The event timing for the BLM system has a dual-class time trigger and a triple-class time window (Figs. 7 and 8). The triggers are divided the digitizer trigger for the beam signal and the heartbeat trigger. The time windows consist of the beam-loss, background, and heartbeat. The beam-loss window is for measuring the beam loss signal. The background window is located between the beam-loss and heartbeat windows for measuring the background noise. The heartbeat trigger is generated 1150 μ s after the digitizer trigger and the heartbeat window start at the same time. The range of whole time window is about 1300 μ s (1024 time unit for the AD) for one pulse. We can control the timing of the triggers and windows freely in this range (Fig. 8).

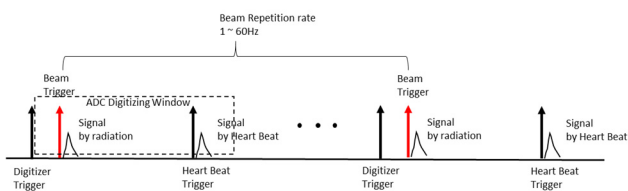

Figure 7: Event trigger for the BLM system.

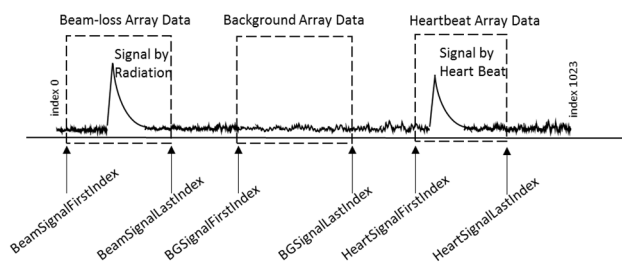

Figure 8: Timing window and data acquisition for the BLM system.

INSTALLATION, CALIBRATION, AND OPERATION

Twenty BLM heads were installed in the intersection for the HX line and 7 ones were installed for the SX line. Three ADCs were installed for the HX line and an ADC was installed for the SX line. The first ADC was connected to the first six BLM heads, the second one was connected the next six heads, and the third one was connected to the final eight heads in the HX line. Figure 9 shows the operation program for one BLM head. It can control the time windows of beam-loss, background, and heartbeat, the PMT control voltage, thresholds, and the pulse width of heartbeat signal. The beam loss (L_{beam}) is calculated by

$$L_{beam} = \frac{\int (\text{loss signal})}{\Delta t_{beam}} - \frac{\int (\text{background signal})}{\Delta t_{back}}, \quad (1)$$

where Δt_{beam} is the time window of beam loss and Δt_{back} is the time window of background. The unit of time is about 1.28 μ s (1/AD frequency).

If L_{beam} exceeds the threshold of beam loss, the BLM system generates interlock to machine interlock system (MIS) and the MIS close the laser shutter in the injector. Also, when the heartbeat signal is less than the heartbeat threshold because of problems in the PMT module, interlock signal is generated.

When the large beam loss occurs, the beam loss signal affects the signal in the time window of background. Therefore, we use the threshold of background – if the background ($\int(\text{background signal})/\Delta t_{back}$) is larger than the threshold of background, the threshold of background is applied for the calculation of L_{beam} (Fig. 10).

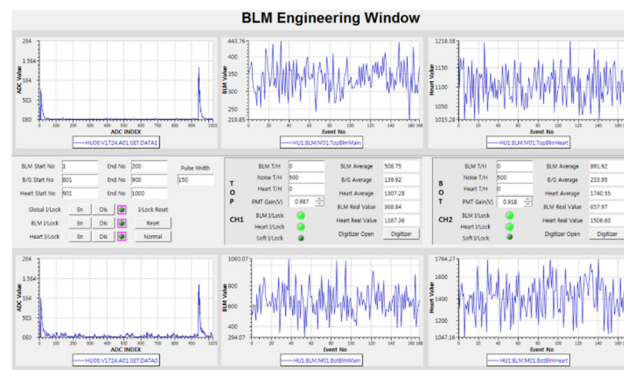

Figure 9: Operation program for the BLM system.

Content from this work may be used under the terms of the CC BY 3.0 license (© 2018). Any distribution of this work must maintain attribution to the author(s), title of the work, publisher, and DOI.

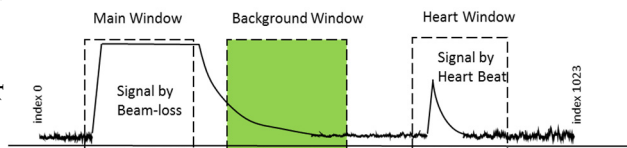

Figure 10: Timing window for the BLM system. When the beam loss affects in the time window of background, the threshold of the background is used.

Since there are different sensitivity in each PMT, the PMT gain (G_{PMT}) were calibrated. We use the heartbeat signal for the criterion of the calibration because the intensities of LEDs and the inner structure of BLM heads are uniform. We applied the heartbeat signal with about 5-V amplitude and 0.9-ms pulse width and adjusted the control voltage until the flat top of the heartbeat signal became 10000 time unit of AD (Fig. 11(a)). We got the calibrated control voltage (V_{cal}) and set that $V_{cal} + 0.6$ V. The relation function between G_{PMT} and control voltage (V_{ctrl}) is

$$G_{PMT,n} = a_n \cdot V_{ctrl,n}^{8.6}, \quad (2)$$

where a_n is a constant for each BLM. The pulse width of heartbeat signal reset 190 μ s for operation (Fig. 11(b)). The time window settings are 1 – 200 for the beam-loss, 801 – 900 for the background, and 901 – 1000 for the heartbeat (Fig. 10). We conduct the beam based alignment, beta matching, and orbit correction for the undulator region. Therefore, we achieve the beam transport with less loss in 4 – 10-GeV, 150-pC e-beam condition.

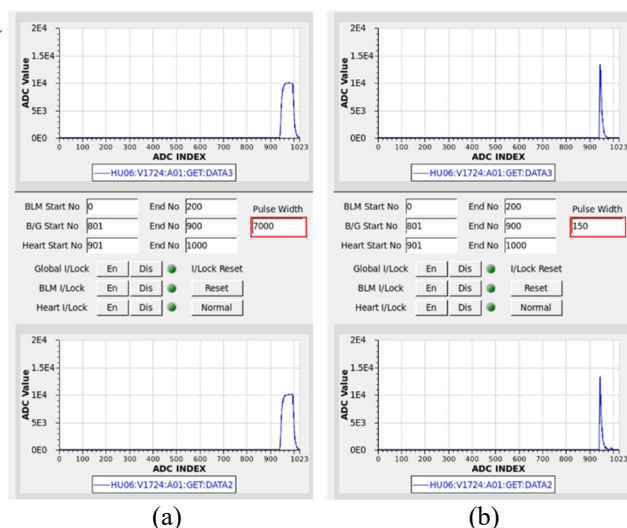

Figure 11: Parameters setting of the BLM system for the (a) calibration and (b) operation.

SUMMARY AND FUTURE WORK

We developed the BLM system to prevent the radiation-induced demagnetization of undulators. It consists of the BLM head and ADC system. The BLM head is based on the Cherenkov radiator. Two fused quartz rods were used for the radiator and located up and down of beam tube. The Cherenkov radiation by the beam loss is measured by PMT module with 230 – 700-nm spectral response range. The PMT signal is digitized in the ADC system and the beam loss calculated from beam-loss and background signal. The heartbeat signal from the LED bulb in the BLM head is also calculated for indicating the BLM system operation.

The ADC system consists of the power unit and the VME system. The power unit supply the gain voltage for the PMT module and the operation power for all sub devices. All analogue signals are digitized to 0.78 MS/s sampling frequency and the time triggers and windows is controlled in the VME system. When the beam loss exceeds the threshold, an interlock signal is sent to the MIS system and it blocks the e-beam generation. 20 BLM heads were installed in the intersection for the HX line and 7 ones were installed for the SX line. 3 ADC were installed for the HX line and one ADC was installed for the SX line. Since there are different sensitivity in each PMT, the PMT gain were relatively calibrated by the heartbeat signal from the LED operation of 5-V and 0.9-ms pulse width.

The integrated value of BLM signal relates the accumulated radiation dose of undulators. If one wants to get the absolute accumulated radiation dose from the BLM signal, the BLM should be calibrated by the dosimetry. We plan this calibration to install the TLD in front of radiators in the BLM head and measure the dose during one FEL operation shift. We expect the correct quantification of the beam loss by this calibration. Also, we expect that it used effectively for the maintenance and replacement of the undulators.

REFERENCES

- [1] J. Arthur *et al.*, “Conceptual design report: Linac Coherent Light Source (LCLS),” SLAC-R-593, 2002.
- [2] S. Gota *et al.*, “XFEL/SPring-8 beamline technical design report,” SPring-8 Technical Document, 2010.
- [3] D. E. Kim *et al.*, in *Proceedings of IPAC’12*, New Orleans Louisiana, USA, p. 1738.
- [4] J. Alderman *et al.*, “Radiation-induced demagnetization of Nb-Fe-B permanent magnets,” LS-290, 2000.
- [5] W. Berg *et al.*, in *Proceedings of LINAC’08*, Victoria, BC, Canada, p. 492.