

COLLIMATION DESIGN AND BEAM LOSS DETECTION AT FRIB*

Z. Liu[†], F. Marti, S. Lidia, S. Cogan, M. Ikegami, FRIB, East Lansing, Michigan, USA
 T. Maruta, J-PARC/JAEA, Ibaraki, Japan
 V. Chetvertkova, GSI, Darmstadt, Germany

Abstract

As a multi-charge-state, heavy-ion, superconducting accelerator with a folded geometry, FRIB faces unique beam loss detection and collimation challenges to protect superconducting cavities from beam-induced damage. Collimation is especially important in the Folding Segment 1 where the multiple charge states are created by a charge stripper and selected by a charge selector. The transported ECR contaminants, interaction with the residual gas, and beam halo due to stripping could induced significant beam losses in this region. We have simulated the potential beam losses and planned collimation accordingly. A layered loss detection network is also specifically designed to visualize potential blind zones and to meet the stringent requirements on loss detection. The related sub-systems are designed and procured and are introduced in this paper.

INTRODUCTION

As a superconducting heavy-ion accelerator, FRIB's folded structure adds additional difficulties to the machine protection and loss monitoring [1]. Among these difficulties, Folding Segment 1 (FS1) and low energy linac segment are two special regions:

Due to the charge stripper and charge selector in FS1, there are several additional beam loss sources, such as the ECR contaminants that are separated from primary beam after charge stripper, beam halo created by stripping, and

charge exchange with residual gas due to the higher pressure around charge selector. These losses require additional collimation planning in FS1.

Radiation cross talk from high energy linac segments and cavity X-ray background make small loss detection especially challenging in the low energy linac segments [1]. We have designed a bunch of loss detectors to compose a multiple layer beam loss monitoring network. Feasibility study has been carried out for each loss detector and DAQ scheme is designed according to detector sensitivity and MPS requirement respectively.

This paper introduces the collimation system design in FRIB FS1 and detectors in the beam loss monitoring network. The DAQ cards and data acquisition scheme is also introduced.

COLLIMATION AT FRIB FS1

In FS1, the charge stripper and charge selector create five charge states from two, e.g. from $U^{33+ \sim 34+}$ to $U^{76+ \sim 80+}$. The five charge states is then transported to Linac Segment 2 (LS2). Figure 1 shows the mechanical drawing of FS1 lattice, on which charge stripper and charge selector are pointed out.

Besides the large intentional beam losses of those charge states that are collimated by charge selector, there are several other potentially significant losses that may need to be collimated.

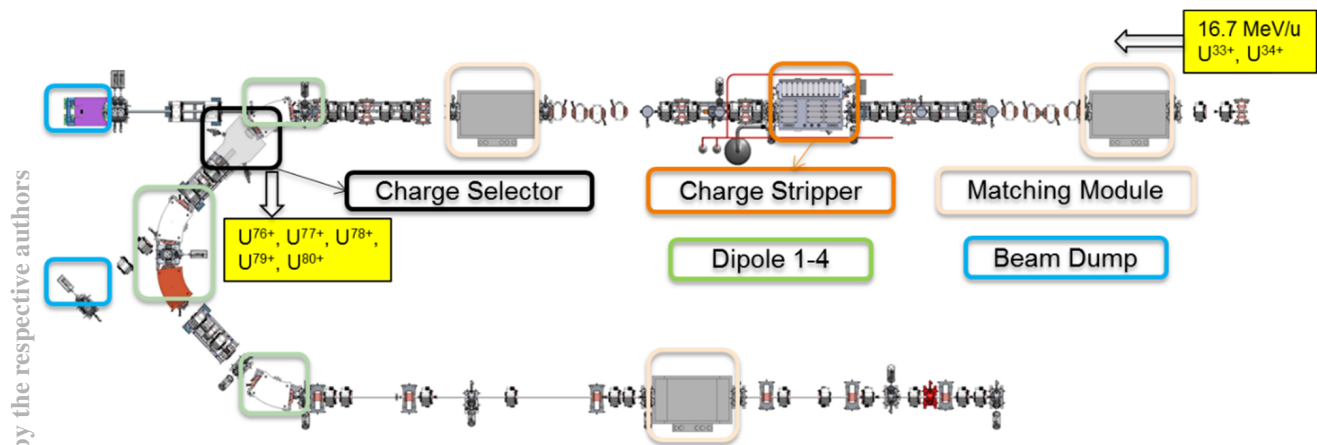

Figure 1: Mechanical drawing of FRIB FS1 lattice. $U^{33+ \sim 34+}$ becomes $U^{76+ \sim 80+}$ after charge selector.

Collimation for ECR Contaminants

The most common contaminants are carbon, nitrogen and oxygen that are coming from outgassing of the ECR plasma chamber wall or hardware introduced by a specific run such as an oven. FRIB's high intensity requirement

* This material is based upon work supported by the U.S. Department of Energy Office of Science under Cooperative Agreement DE-SC0000661.

[†] liuz@frib.msu.edu

pushes to operate the ion source at high microwave power, which leads to additional outgassing and conditioning. The amount of these contaminants depend on the time available for outgassing, and could be up to 5% of primary particle number in a bad case.

These contaminants, if have the same Q/A as the primary beam before FS1, e.g. N^{2+} contaminants for U^{34+} beam, can be transported through Linac Segment 1 (LS1). After charge stripping, the contaminant has larger Q/A (e.g. N^{7+} $Q/A=0.5$) than the beam and different focusing and bending path.

Contaminant losses are simulated between the charge stripper and charge selector, with larger Q/As compared with primary $U^{76+ \sim 80+}$ beam: $Q/A = 0.35, 0.40, 0.42, 0.45, 0.50$ was simulated [2]. With these simulations, five collimator locations are defined, as shown in Figure 2. According to the transmission plot at the bottom, 90% of $Q/A=0.40$ contaminants are collimated by the new collimators, only 10% of such contaminants lost in the 1st bending magnet. The vacuum chamber of the 1st bending magnet still need water cooling though.

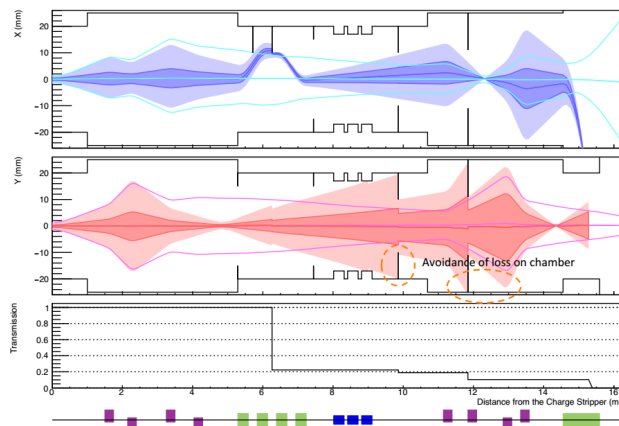

Figure 2: Simulation of $Q/A=0.40$ contaminant loss with five collimators between charge stripper and charge selector. The small aperture “collimator” in the middle is Halo Monitoring Ring. . The color lines are envelope of uranium beam, dark color represents rms envelope of contaminant particles while pale region represents 100% envelope.

Beam Halo Induced by Charge Stripping

Charge stripping could also create significant beam halo for the primary beam. If no collimation is planned for that, the beam halo could become losses at superconducting cavities downstream in Linac Segment 2 (LS2). To protect critical equipment such as superconducting cavities, collimators should be planned before LS2.

To simulate the potential losses, artificial beam halo was created by increasing the nominal beam size. Particle tracking was then implemented in MAD-X. Collimators are planned before critical equipment such as magnet, superconducting cavities and bellows, as shown in Figure 3.

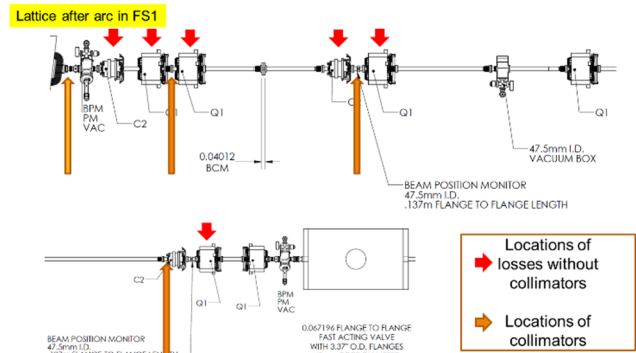

Figure 3: Lattice after arc in FS1 with collimator locations.

Secondary losses, i.e., primaries and fragments that escaped from collimator, were also simulated at collimator. The collimators are determined to be elliptical shape that can cut both horizontal and vertical tails, with apertures about 5-6 times of rms beam size.

Charge Exchange with Residual Gas

Charge exchange with residual gas could be a source of beam losses due to relatively high pressure around charge selector. Figure 4 shows the simulated vacuum profile around the charge selector. Compared with superconducting region ($\sim 10^{-9}$ Torr), the pressure at charge selector could be 3 order of magnitude higher.

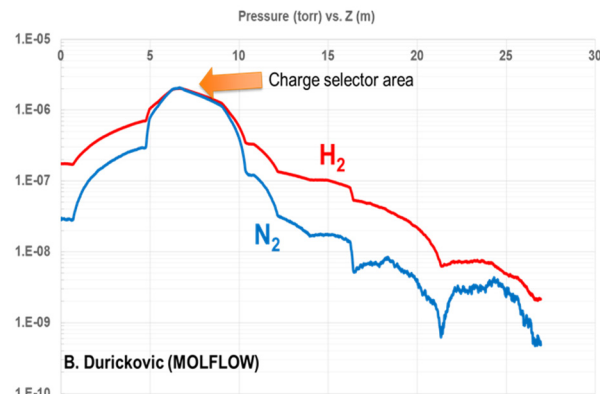

Figure 4: Simulated vacuum profile around charge selector, from the entrance of 1st bending magnet to end of FS1.

We can estimate the fractional charge exchange rate using the electron capture cross section:

$$\frac{N_o - N}{N_o} \sim 1 - e^{-\int_0^L \sigma n dl}$$

where σ is the electron capture cross section for U^{73+} [3], and $n = p/kT$, for H_2 and N_2 respectively.

The fractional beam loss induced by charge exchange is thus 7 ppb for H_2 , and 10 ppm for N_2 . Most losses occur at charge selector area and we should plan collimator after it.

The location of collimator can be determined by simulating charge exchange induced losses [2]. Losses mainly caused by U^{81+} that is stripped from U^{80+} . An easy way to simulate the loss location is to assume uniform charge exchange rate over the whole length (from the entrance of 1st bending magnet to end of FS1). A new collimator before

the 2nd sextupole in the arc, together with previous beam halo collimators, can stop beam losses generated in charge selector area completely [2]. But 6% of other charge exchange particles escape the collimators and goes into LS2 [2]. HMR aperture in LS2 may need to be optimized to protect superconducting cavity.

FRIB LOSS MONITORING NETWORK

Since superconducting cavities are very sensitive to beam losses, FRIB machine protection requirement is made comparable to proton machine: Detector should response to Fast Protection System (FPS) in 15 μ s for large fractional loss and be capable to detect 1 W/m or equivalent small losses in the superconducting region.

However, FRIB's special folded structure [1] greatly challenge the conventional BLM system, i.e. the ion chamber. The challenges can be summarized as:

- Heavy ion produces less radiation. Therefore the signal is much smaller for 1 W/m beam loss compared with proton machine
- Cavity X-ray background is high compared with low energy beam loss signal
- Significant radiation cross talk from high energy segments to low energy segment disable loss location determination

To fulfil FRIB machine protection requirement, we developed a multiple layer beam loss monitoring network that is composed of a bunch of beam loss detectors: Differential Beam Current Monitor (DBCM), Ion Chamber (IC), Halo Monitor Ring (HMR) [4], Fast Thermometry System (FTS), Neutron Detector (ND) and Cryogenic System Monitor (Cryo). The layered network is shown as Table 1.

Table 1: Multiple Layer Beam Loss Monitoring Network

Fast Losses (response in 15 μ s)			
	Primary	Secondary	Tertiary
LS1	DBCM	HMR	
FS1	DBCM	HMR	IC
LS2 low E	DBCM	HMR	
LS2 high E	DBCM	IC	HMR
FS2	DBCM	IC	HMR
LS3	DBCM	IC	HMR
BDS	DBCM	IC	

Slow Losses (1 W/m)			
	Primary	Secondary	Tertiary
LS1	HMR/FTS	HMR/FTS	Cryo
FS1	HMR	IC	
LS2 low E	HMR/FTS	HMR/FTS	Cryo
LS2 high E	IC	HMR/Cryo	
FS2	IC	HMR	
LS3	IC	HMR/Cryo	HMR
BDS	IC		

The neutron detector mainly serves as background detector and will be also helpful for LS1 tuning.

Per machine protection requirement, Table 2 shows example signal amplitudes with acquisition times for IC and HMR, where HMR signal is estimated as consolidated loss over cryomodule and IC signal is based on minimum sensitivity requirement 1.5nA/R/hr. The priority of each loss detector in loss monitoring network is determined by its signal amplitude and acquisition time. For example, ion chamber imposes a limitation on noise requirement of the DAQ card, i.e. 10% of 350 pA in 150 μ s, since integration time \times 10 corresponds to signal amplitude $/\sqrt{10}$.

Table 2: Signal Amplitude Estimation, Acquisition Time and Corresponding Loss Level for HMR and IC

SIG-NAL	LS1	LS2	LS3	T _{DAQ}	LOSS LEVEL
HMR	10nA	2nA	1nA	1.5s	0.1W/m
	100nA	20nA	10nA	15ms	1W/m
	1 μ A	200nA	100nA	150 μ s	10W/m
	10 μ A	2 μ A	1 μ A	15 μ s	100W/m
IC	N/A	3.5pA	42pA	1.5s	0.1W/m
	N/A	35pA	420pA	15ms	1W/m
	N/A	350pA	4.2nA	150 μ s	10W/m
	N/A	3.5nA	42nA	15 μ s	100W/m

FRIB will procure three DAQ cards for loss detectors, i.e. CAENels AMC-PICO-8 card for HMR, IC and ND, Struck SIS8300-L2 card for DBCM, and FRIB Digital Board for general purpose such as interfacing with the Global Timing System (GTS) and Fast Protection System (FPS). These DAQ cards will be installed in a MicroTCA.4 chassis, which is used as the platform for most of the FRIB "fast" diagnostics that interface with FPS and acquire "fast" data (>10 kHz). 75% of FRIB diagnostic devices are covered by these 3 MicroTCA cards.

Among these 3 cards, CAENels AMC-PICO-8 is specifically customized for loss diagnostics while it also serves Faraday Cups, Allison Scanner and Profile Monitor. It is a fast picoammeter that features 8 channels @ 1 MS, with ~35 kHz bandwidth. It has a switchable dynamic range of 16 μ A or 130 μ A, and a tolerable noise requirement for loss monitors, as shown in Table 3.

Table 3. Noise Requirement and Measurement of CAENels AMC-PICO-8 Card. The noise level was measured with a 150 ft cable.

Sample Time	Noise requirement (35 kHz, 1 μ A)	Noise measurement (35 kHz, 16 μ A)
1 μ s	770 pA	995 pA
15 μ s	199 pA	220 pA
150 μ s	35 pA	68 pA
100 ms	2.43 pA	2.63 pA

The measured noise level for 150 μs sampling time is about twice of the requirement, which is 10% of the minimum IC signal. Considering the IC signal is estimated based on minimum IC sensitivity and 20% noise level is still tolerable, we accept the fast picoammeter card as our loss monitor DAQ card.

A common feature for these three cards is background subtraction capability. Depending on the signal, background could be electrical measurement offset, or cavity X-ray background for ion chamber. The power line harmonics (60 Hz, 180 Hz) will also be sampled and subtracted by Struck card for BCM. All three fast DAQ cards are capable to subtract background in the 50 μs beam gap period. This implies the requirement for 35 kHz bandwidth in order to sample at the second half of beam gap, as shown in Figure 5.

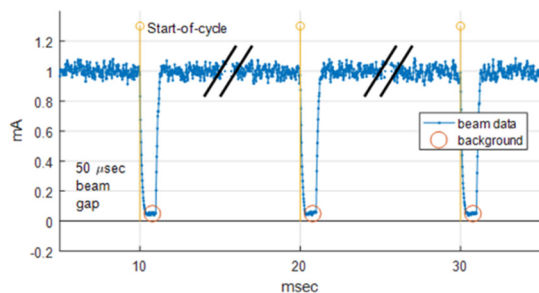

Figure 5: Background sampling at the 2nd half of beam gap.

Rather than DBCM, HMR, IC and ND, FTS only serve slow loss monitoring and does not interface with FPS. Its feasibility has been validated with In-Cryomodule test [5]. Its DAQ system is a commercial temperature monitor and the data will be directly fed into EPICS.

CONCLUSION

In this paper, we have introduced the collimation consideration for FRIB machine, especially at Folding Segment 1, the most concerned area due to charge stripper and charge selector. Ten collimators are planned in FS1 to eliminate losses induced by ECR contaminants, beam halo and charge exchange. These collimations, will protect critical equipment such as magnets, superconducting cavities

and bellows. However, such intensive collimations also introduce intentional losses that add difficulty to detect uncontrolled losses. While we can measure beam current at several locations and monitor the change of ratio for unexpected losses, instrumenting collimators in the arc for differential loss monitoring is also encouraged. If the intentional loss is stable on the time scale of few seconds, we should be able to subtract it for small loss monitoring at FS1.

The FRIB loss monitoring network, composed of different layers of loss detectors, was introduced to overcome radiation cross talk issue and fulfil 1 W/m machine protection requirement for superconducting region. We have defined the requirement for DAQ system according to the machine protection requirement, priority of detectors in the network, and detector signal estimations. The DAQ cards that meets the requirement were introduced. We are now on the track for pre-installation/integration tests. The commissioning of loss monitors and feasibility of loss network will be reported in the future.

ACKNOWLEDGMENT

T. Maruta and V. Chetvertkova provide their simulation and collimation design result for this paper.

The authors want to thank A. Hussain, Z. Zheng and Colleagues in FRIB Diagnostics group for generous help and fruitful discussions.

The authors also want to thank FRIB management team for support of this work.

REFERENCES

- [1] Z. Liu *et al.*, “Beam Loss Monitor System for the Low-Energy Heavy-Ion FRIB Accelerator”, in *Proc. IBIC'13*, Oxford, UK, paper MOPC46.
- [2] T. Maruta *et al.*, “Simulation Study on the Beam Loss Mitigation in the 1st Arc Section of FRIB Linac”, submitted to LINAC'16, East Lansing, MI, USA (2016).
- [3] V. P. Shevelko *et al.*, *NIM B* 278 (2012) 63.
- [4] Z. Liu *et al.*, *NIM A* 767 (2014) 262-266.
- [5] Z. Zheng *et al.*, “Cryogenic Thermometers as Slow Beam Detectors”, in *Proc. IBIC'15*, Melbourne, Australia, paper MOPB073.