

MAGNETIC FIELD TRACKING AT CSNS/RCS

S. Y. Xu*, S. N. Fu, S. Wang, W. Kang, X. Qi
 CSNS/IHEP, CAS, Dongguan, 523803, P.R. China

Abstract

Because of the differences of magnetic saturation and eddy current effects between different magnets, magnetic field tracking errors between different magnets is larger than 2.5% at the Rapid Cycling Synchrotron (RCS) of Chinese Spallation Neutron Source (CSNS), and the induced tune shift is larger than 0.1. So large tune shift may lead the beam to pass through the resonance lines. To reduce the magnetic field tracking errors, a method of wave form compensation for RCS magnets, which is based on transfer function between magnetic field and exciting current, was investigated on the magnets of CSNS/RCS. By performing wave form compensation, the magnetic field ramping function for RCS magnets can be accurately controlled to the given wave form, which is not limited to sine function. The method of wave form compensation introduced in this paper can be used to reduce the magnetic field tracking errors, and can also be used to accurately control the betatron tune for RCS. By performing wave form compensation, the maximum magnetic field tracking error was reduced from 2.5 % to 0.08 % at CSNS/RCS. The wave form compensation was applied to CSNS/RCS commissioning.

INTRODUCTION

The Chinese Spallation Neutron Source (CSNS) is an accelerator-based science facility. CSNS is designed to accelerate proton beam pulses to 1.6 GeV kinetic energy, striking a solid metal target to produce spallation neutrons. CSNS has two major accelerator systems, a linear accelerator (80 MeV Linac) and a rapid cycling synchrotron (RCS). The function of the RCS accelerator is to accumulate and accelerate protons from the energy of 80 MeV to the design energy of 1.6 GeV at a repetition rate of 25 Hz [1, 2]. The magnetic field tracking is an important issue for CSNS/RCS. The magnetic field tracking errors between the quadrupoles and dipoles can induce tune shift. If the tune shift induced by magnetic field tracking errors is large enough to pass through the resonance line, emittance growth as well as beam losses will occur [3-5].

Because of the magnetic saturation and the eddy current effects, there may be magnetic field tracking errors between different magnets of CSNS/RCS. For the magnets of RCS, which are powered by resonant circuits [6, 7], the exciting current and magnetic field is unable to be controlled step by step during ramping. For this type of magnets, the feed-back system is unable to be used to accurately control the magnetic field ramping wave form. The accurate magnetic field tracking was achieved by performing harmonic filed correction at J-PARC/RCS [8]. To

reduce the magnetic field tracking errors for CSNS/RCS, a method of wave form compensation for RCS magnets was investigated. By performing wave form compensation, the magnetic field ramping function for RCS magnets can be accurately controlled to the given wave form, which is not limited to sine function.

INTRODUCTION OF THE NEW METHOD OF WAVEFORM COMPENSATION

The new method of waveform compensation is based on transfer function between magnetic field and exciting current of the magnets of RCS. Higher order time harmonics of exciting current, which are computed based on transfer function, are injected into the magnets to compensate higher order time harmonics of magnetic field, and the magnetic field during the exciting current ramping can be accurately controlled.

The flow process for the harmonic compensation is shown in Fig. 1. For a start, the magnetic field and exciting current at different time during the exciting current ramping are measured by using the harmonic coil measurement system [9, 10], and then the fit of the transfer function $I=F_{Down}(B)$ and $I=F_{Upward}(B)$ are made to reduce the effect of measurement noise. $I=F_{Upward}(B)$ and $I=F_{Down}(B)$ are the transfer functions for that the exciting current ramping upward and downward respectively. By using the transfer function, the exciting current as a function of time $I(t)$ corresponding to the given magnetic field pattern $B(t)$ is derived. Then the DC offset and time harmonics of the derived current are obtained through FFT to $I(t)$. The magnetic field as a function of time can be accurately compensated to the given pattern $B(t)$ by inputting the obtained DC offset and time harmonics of the current into the resonant power supply.

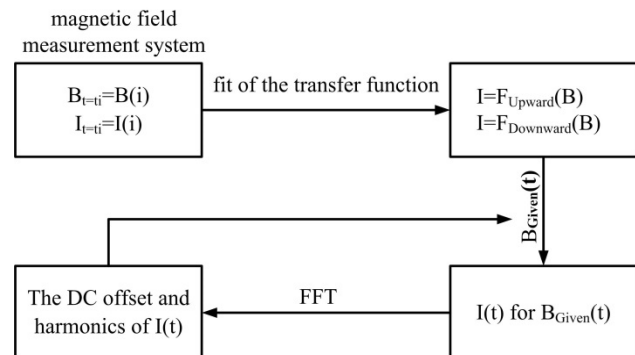

Figure 1: The flow process diagram for the harmonic compensation.

For the magnet of RCS with serious magnetic saturation and eddy current effects, the magnet field control accuracy is not high enough with only once waveform compensation, such as 206Q of CSNS/RCS. The method

Content from this work may be used under the terms of the CC BY 3.0 licence (© 2018). Any distribution of this work must maintain attribution to the author(s), title of the work, publisher, and DOI.

* xusy@ihep.ac.cn

of waveform compensation introduced in this paper can be performed repeatedly.

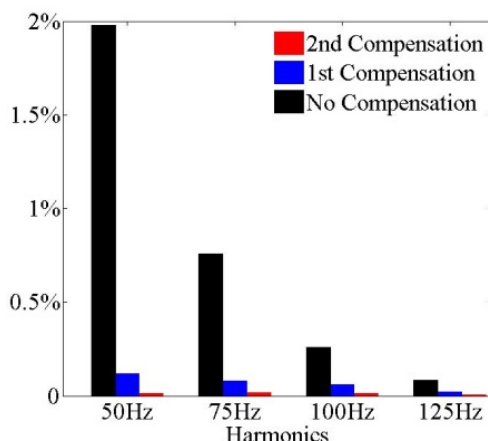

Figure 2: Comparison of the ratio of higher order harmonics and fundamental harmonics with and without waveform compensation.

The magnetic field of 206Q was compensated to sine pattern by using twice waveform compensation, and the test results are shown in Fig. 2. The higher order harmonics were effectively reduced by using once waveform compensation, but the ratio of some higher order harmonics and fundamental harmonic is still high, such as 50Hz harmonic, which is larger than 0.1% of fundamental harmonic. By using the second time waveform compensation, which is based on the transfer function between magnetic field and exciting current after the first time harmonic compensation, all the higher order harmonics were reduced to lower than 0.02% of fundamental harmonic. In other words, the magnetic field of 206Q was compensated to almost sine pattern by using twice waveform compensation. On the same principles, the method of waveform compensation can be performed even more times to achieve higher magnetic field control accuracy for the magnets of RCS with serious magnetic saturation and eddy current effects.

APPLICATION OF THE METHOD OF WAVE FORM COMPENSATION TO CSNS/RCS

The method of wave form compensation for magnets of RCS was applied to CSNS/RCS to reduce the magnetic field tracking errors between different magnets. There are one type of dipole named 160B and four types of quadrupoles, named 272Q, 253Q, 222Q and 206Q respectively at CSNS/RCS. Because of the differences of magnetic saturation and eddy current effects between these five types of magnets, there are magnetic field tracking errors between different magnets before wave form compensation, as shown in Fig. 3. The maximum magnetic field tracking error between the dipole and quadrupoles is larger than 2.5% over the ramping process, and the induced tune shift is larger than 0.1. So large tune shift may lead the beam to pass through the resonance lines.

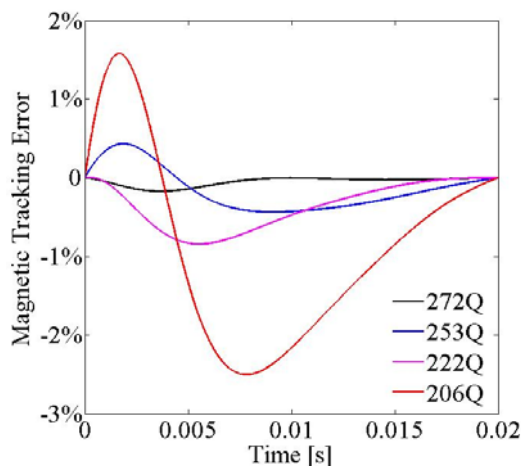

Figure 3: Magnetic field tracking errors between the dipole and four types of quadrupoles over the ramping process with no wave form compensation.

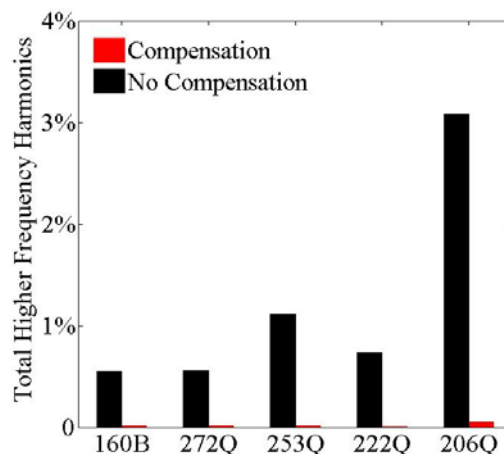

Figure 4: Comparison of the ratio of total higher order harmonics and fundamental harmonic with and with no wave form compensation for different types of magnets of CSNS/RCS.

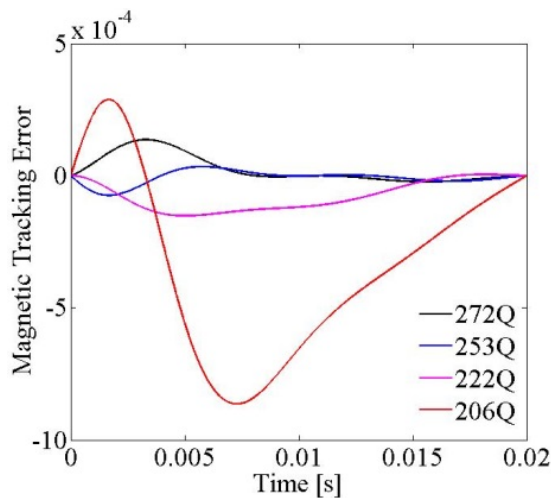

Figure 5: Magnetic field tracking errors between the dipole and four types of quadrupoles over the ramping process after wave form compensation.

To reduce the magnetic field tracking errors between different magnets, wave form compensation was performed on all the magnets of CSNS/RCS. The magnetic field ramping functions for all the magnets were compensated to sine pattern. As shown in Fig. 4, higher order time harmonics of magnetic field for all the types of magnets were reduced to almost zero by performing wave form compensation, with only fundamental harmonic remained. The maximum magnetic field tracking error between the dipole and quadrupoles was reduced from 2.5% to 0.08%, as shown in Fig. 5, and the maximum tune shift over the ramping process was reduced from 0.1 to 0.004.

APPLICATION OF THE METHOD OF WAVE FORM COMPENSATION TO CSNS/RCS COMMISSIONING

The method of wave form compensation for magnets of RCS was applied to CSNS/RCS commissioning. The AC mode beam commissioning of CSNS/RCS with the injection energy of 80 MeV was started on January 18, 2018, and 1.6 GeV acceleration was successfully accomplished for the first beam shot. The beam transmission rate got 100% after performing the match of dipole magnetic field and RF frequency on the same day, as shown in Fig. 6.

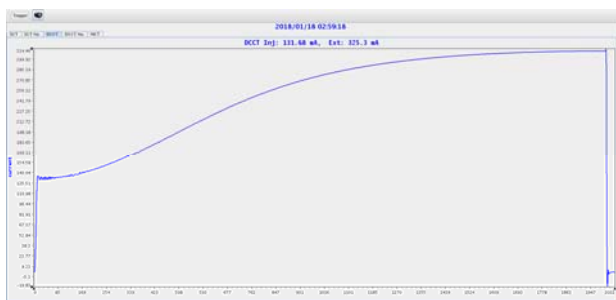

Figure 6: The beam current over one cycling period. Beam current increase with the increase of revolution frequency.

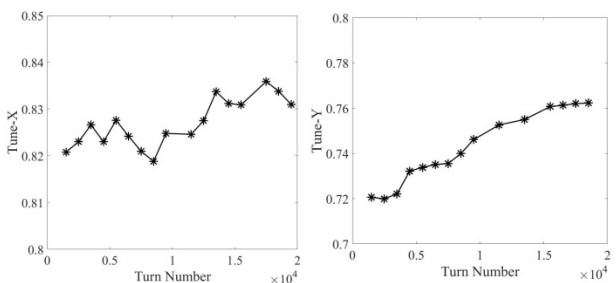

Figure 7: The tune variation during the acceleration process over one cycling period.

The tunes are measured during the acceleration process over one cycling period. The measurement results are shown in Fig. 7. The variation of horizontal tune is less than 0.02, and the variation of vertical tune is about 0.04. The tune variation during the acceleration process is significantly smaller than the tune shift induced by the magnetic field tracking errors without wave form compensa-

tion, which is 0.1. However, the tune variation during the acceleration process is bigger than the tune shift induced by the magnetic field tracking errors with wave form compensation, which is 0.004. The tune variation during the acceleration process can be induced by space charge effects, the mismatch between magnetic field and RF frequency, and timing errors between different magnet power supplies, except for the magnetic field tracking errors induce by the differences of higher order harmonics between different magnets.

CONCLUSION

A method of wave form compensation for the magnets of RCS is introduced in this paper. The method of wave form compensation can be used to accurately control the magnetic field ramping. The method of wave form compensation was applied to CSNS/RCS commissioning. The magnetic field tracking errors between different magnets are effectively reduced, and the beam commissioning of CSNS/RCS went smoothly.

REFERENCES

- [1] S. N. Fu *et al.*, “Status of CSNS Project”, in *Proc. IPAC’13*, Shanghai, China, May 2013, pp. 3995-3999.
- [2] S. Wang, *et al.*, “An Overview of Design for CSNS/RCS and Beam Transport”, *Science China Physics, Mechanics & Astronomy*, vol. 54, pp. 239-244, 2011.
- [3] H. Hotchi *et al.*, “Effects of Magnetic Field Tracking Errors on Beam Dynamics at J-PARC RCS”, in *Proc. PAC’07*, Albuquerque, NM, USA, Jun. 2007, pp. 4078-4080.
- [4] S. Y. Xu *et al.*, “Effects of Magnetic Field Tracking Errors and Space Charge on Beam Dynamics at CSNS/RCS”, in *Proc. HB’12*, Beijing, China, Sep. 2012, pp. 484-486.
- [5] S. Y. Xu *et al.*, “Study on the Effects of Chromaticity and Magnetic Field Tracking Errors at CSNS/RCS”, *Chinese Physics C*, vol. 38, pp. 68-71, 2014.
- [6] N. Tani *et al.*, “Design of RCS Magnets for J-PARC 3-GeV Synchrotron”, *IEEE Tran. Appl. Supercond.*, vol. 14, pp. 409-412, 2004.
- [7] S. N. Fu *et al.*, “Proton Accelerator Development in China”, *AC13*, pp. 57-61, 2013.
- [8] N. Tani, *et al.*, “Magnet System of the J-PARC RCS”, 3th ACFA-HPPA Mini-Workshop, 2008.
- [9] J. X. Zhou *et al.*, “A Harmonic Coil Measurement System Based on a Dynamics Signal Acquisition Device”, *Nucl. Instrum. Methods Phys. Res. A*, vol. 624, pp. 549-553, 2010.
- [10] J. X. Zhou, *et al.*, “AC Magnetic Field Measurement of CSNS/RCS Quadrupole Prototype”, *Nucl. Instrum. Methods Phys. Res. A*, vol. 654, pp. 72-75, 2011.

Content from this work may be used under the terms of the CC BY 3.0 licence (© 2018). Any distribution of this work must maintain attribution to the author(s), title of the work, publisher, and DOI.