

DESIGN AND BEAM TEST RESULTS OF THE REENTRANT CAVITY BPM FOR THE EUROPEAN XFEL

C. Simon*, M. Baudrier, M. Luong, L. Maurice, O. Napoly,
CEA-Saclay/DRF/Irfu, Gif sur Yvette, France

N. Baboi, D. Lipka, D. Noelle, G. Petrosyan DESY, Hamburg, Germany
R. Baldinger, B. Keil, G. Marinkovic, M. Roggli, PSI, Villigen, Switzerland

Abstract

The European X-ray Free Electron Laser (E-XFEL) will use reentrant beam position monitors (BPMs) in about one quarter of the superconducting cryomodules. This BPM is composed of a radiofrequency (RF) reentrant cavity with 4 antennas and an RF signal processing electronics. Hybrid couplers, near the cryomodules, generate the analog sum and difference of the raw pickup signals coming from two pairs of opposite RF feedthroughs. The resulting sum (proportional to bunch charge) and difference signals (proportional to the product of position and charge) are then filtered, down-converted by an RF front-end (RFFE), digitized, and digitally processed on an FPGA board.

The task of CEA/Saclay was to cover the design, fabrication and beam tests and deliver these reentrant cavity BPMs for the E-XFEL linac in collaboration with DESY and PSI.

This paper gives an overview of the reentrant BPM system with focus on the last version of the RF front end electronics, signal processing, and overall system performance.

Measurement results achieved with prototypes installed at the DESY FLASH2 linac and in the E-XFEL injector are presented.

INTRODUCTION

The European XFEL [1] is an X-ray free electron laser user facility installed in Hamburg, Germany. The beginning of commissioning is planned by the end of 2016. This accelerator has a superconducting 17.5 GeV main linac based on the TTF technology and its parameters are summarized in Table 1.

Table 1: E-XFEL Accelerator Parameters

Parameter	Value
Typical beam sizes (RMS)	20 – 200 μm
Nominal bunch charge	0.02 – 1 nC
Bunch spacing	≥ 222 ns
Macro-pulse length	600 μs
Number of bunches within macro-pulse	1 – 2700
Nominal macro-pulse repetition rate	10 Hz

Each module includes a string of eight 1.3 GHz RF cavities, followed by a BPM connected to a superconducting quadrupole. Two types of cold BPMs are installed

* claire.simon@cea.fr

along the machine: cold reentrant BPMs and button BPMs which are not discussed here [2].

The cold reentrant BPM has a beam pipe aperture of 78 mm. It has to measure position and charge, to allow bunch to bunch measurements with a resolution better than 50 μm , a charge between 20 pC and 1 nC and an operating dynamic range of ± 10 mm.

To measure the behaviour of reentrant BPM with the electronics final version in its environment (Modular BPM Unit), beam measurements were done on a reentrant cavity BPM installed in a warm part at FLASH2 [3] and on the first cold reentrant BPM installed in the 3.9 GHz cryomodule during the commissioning of the E-XFEL injector [4].

REENTRANT BPM SYSTEM

This type of BPM is composed of a radio-frequency reentrant cavity [5], which has to operate in a clean and cryogenic environment, and an analog front end electronic (RFFE) which provides the signals to a digital back end, connected to the control system.

Passing through the cavity, the beam excites electromagnetic fields (resonant modes), which are coupled by four feedthroughs to the outside. The voltage differences (Δ) from two opposite antennas correspond to the voltage of the dipole field in the X and Y axis and the sums (Σ) correspond to the voltage of the monopole field. The Δ and Σ signals are obtained from passive 4-ports 180° hybrid couplers. Each coupler is connected to a pair of opposite antennas and transmits the signals to the radio-frequency Front end electronics via some cables.



Figure 1: Reentrant RFFE board.

The reentrant Radio-Frequency Front End board (Fig.1) uses a single stage down-conversion to process the Δ/Σ signals. It is based on a Printed Circuit Board (PCB) with surface mount components and uses the VME64x form factor as required by the generic E-XFEL digitizer and

crate electronics called Modular BPM Unit (MBU) developed by PSI. The electronics of the E-XFEL BPM system follows a modular design approach [6]. This crate contains a generic digital back-end (GPAC) with two ADC mezzanine boards, and either two reentrant BPM RFFEs or one reentrant cavity BPM RFFE and up to two button BPM RFFEs together, as well as power supplies, fans, a rear IO module with digital and multi-gigabit fiber optic IOs for timing and control system interfaces (Fig. 2).

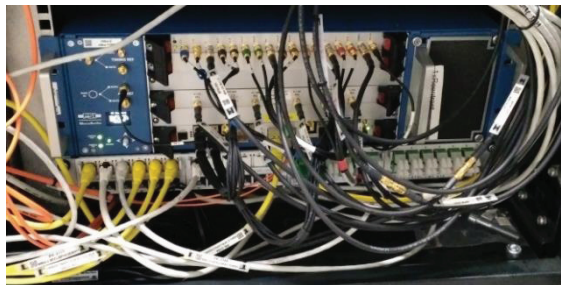

Figure 2: MBU crate installed at the E-XFEL injector with one reentrant RFFE (top), one button RFFE and the generic digital back-end with two ADC mezzanine boards.

RF/Analog Electronics

The RFFE analog electronics design, presented in Fig. 3, has three channels to perform single-stage down-conversion of X/Y positions and reference (charge). Monopole and dipole mode frequencies of the pickup are respectively 1255 MHz and 1724 MHz [7].

On the Δ channels, a band pass filter centered around 1725 MHz, was designed to reject the monopole mode frequency and high order modes. Its bandwidth of 102 MHz also provides a noise reduction. Band pass filters, followed by a variable gain section, allow the analog gain adjustment to the beam charge. It combines two selectable paths: one with a direct path and one with a

31.5 dB range step programmable variable attenuator and low noise amplifier (LNA). A diode is added to protect the variable attenuator and LNA in case of excessive beam offsets. To protect mixers from possible high output power, RF limiters are used.

The very low external quality factor ($Q = 24$) [7] and the amplitude level of the monopole mode allows the electronics to filter around the dipole mode frequency and still to obtain a sufficiently large signal level. The Σ channel has only one gain range and uses the same variable attenuator and LNA. A diode for the LNA protection is added in case of the wrong switching of attenuator.

The signals are, then, translated to a lower IF signal by an in-phase/quadrature-phase (I/Q) down-conversion on each channel using a local oscillator (LO) signal. The I/Q down-conversion is composed of mixers used for systems with high dynamic range, and 90° hybrid couplers chosen for their low phase and amplitude imbalances. The LO signal operates around the dipole mode frequency and is locked to the reference signal 216.666 MHz from the machine. To generate this signal, a phase-locked loop (PLL) is combined to a divider using an intermediate frequency 9.028 MHz. A programmable phase shifter allows keeping a constant phase on the Σ signal thanks to a digital feedback implemented on a FPGA on the GPAC. With a 216.666 MHz on-board oscillator integrated to the electronics, the LO signal can also operate without external reference clock in a free-running mode. To communicate with the digital board and pilot PLL, phase shifter, variable attenuators, I2C bus is used.

The output I/Q IF signals are then amplified by differential amplifiers. They deliver to ADCs, a pulse signal of full width around 15 ns for the charge signal reading and around 25 ns for the beam position signal reading with a shape close to a Gaussian shape.

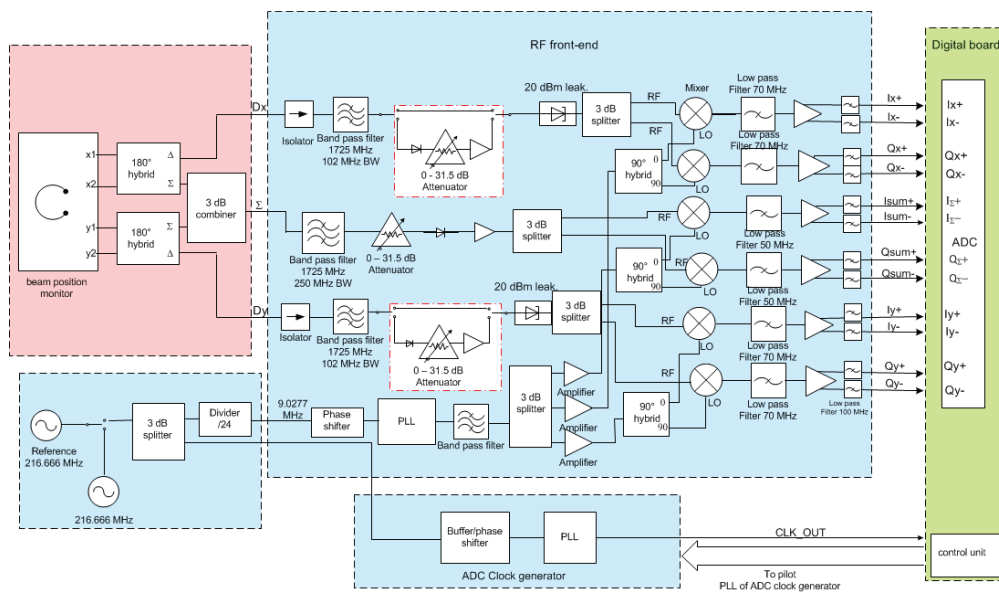

Figure 3: Block diagram of the cold reentrant BPM.

This I/Q down-conversion of Δ and Σ channels allow the digital back-end to determine the sign of the beam position just by comparing the phases of the signals, independently of beam arrival time jitter and external reference clock phase. A serial EEPROM to identify each BPM, a hot swap control to safely insert and remove modules without switching off MBU power are, also, inserted on this RFFE board.

The ADC clock, generated at 162.5 MHz and integrated on the PCB, is also locked to the reference signal and uses a programmable phase shifter and PLL. The sampling and the interface to the control-system are carried with 16 bits ADCs digital electronics operating at 160 Msps, designed and programmed by PSI.

The timing of signals from Δ channels is adjusted by the adding of some delays (cables) to get their top to the same time of the Σ channel maximum.

Digital Signal Processing

A signal processing algorithm [8] is used to determine the beam positions (X and Y) and charge from the signals read by ADCs. This algorithm was implemented in the FPGA board. The ADC phase is automatically tuned for a peak detection of RFFE output signals. Then, a cartesian-to-polar conversion is performed to determine the amplitude and phase of each channel. To compensate some imperfections due to non-ideal analog components, a pre-calibration is performed for I/Q imbalance, attenuation and phase settings of the digital step attenuators and final correction gain factors. Scaling coefficients are also implemented to give the right value.

BEAM MEASUREMENTS

In 2015-2016, beam tests were done with a reentrant BPM installed in a warm section at FLASH2 (Fig. 4) and another BPM installed in the 3.9 GHz cryomodule at the E-XFEL injector (Fig. 5).

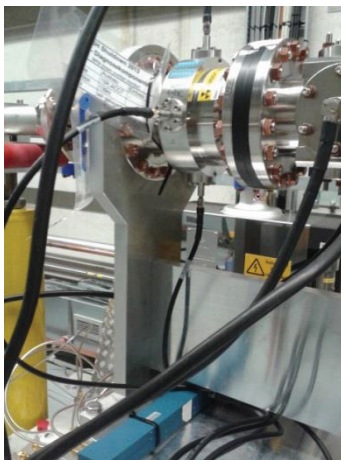

Figure 4: Reentrant BPM (centre) installed on the linac FLASH2 with 180° hybrid couplers.

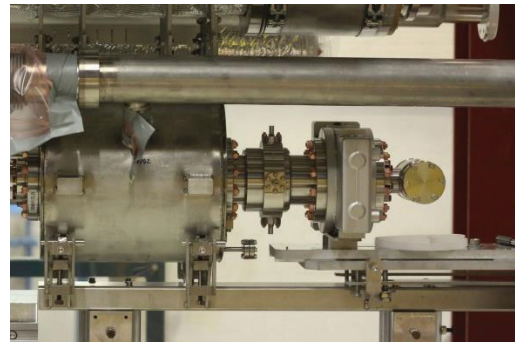

Figure 5: Cold Reentrant BPM with its quadrupole installed at the 3.9 GHz cryomodule.

For an optimal operation on the accelerator, the reentrant BPMs are fully integrated into the DOOCs E-XFEL accelerator control system (a parallel EPICS system from PSI is also implemented to allow laboratory tests and precalibration).

The absolute calibration of the BPM charge reading is carried out by comparing the charge read by a nearby toroid to the charge read by the BPM studied. Figure 6 shows a good correlation between charge reading of the cold reentrant BPM and the reading of the nearby toroid.

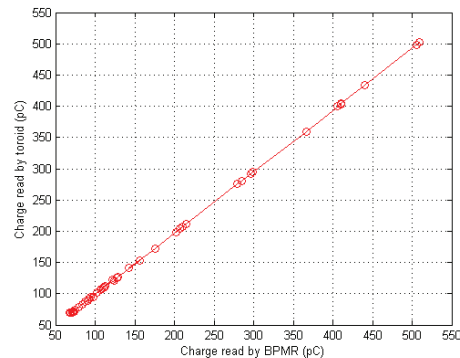

Figure 6: Charge read by toroid vs charge read by the cold reentrant BPM at the E-XFEL injector

To calibrate the position reading, the relative beam displacement (Δx) at the BPM location is calculated by using a transfer matrix (R_{12}) between steerers and BPM (made of drifts) for different values of drive current in the steerers: $\Delta x = R_{12} \cdot \Delta x_0$ (where Δx_0 is the beam angle at steerer position). The steerers are used to deflect the beam, and the magnets between the steerers and the BPM are switched off to reduce errors and simplify calculation. An average of 100 points for each steerer setting is used and a calibration coefficient is computed from a linear fit of the predicted position to the measured position. After adjustment of coefficients, Fig. 7 shows a good linearity in a dynamic range ± 13 mm in horizontal and vertical planes for a charge of 0.4 nC. An offset on Δx and Δy channels was added in the acquisition software to read a zero in this condition.

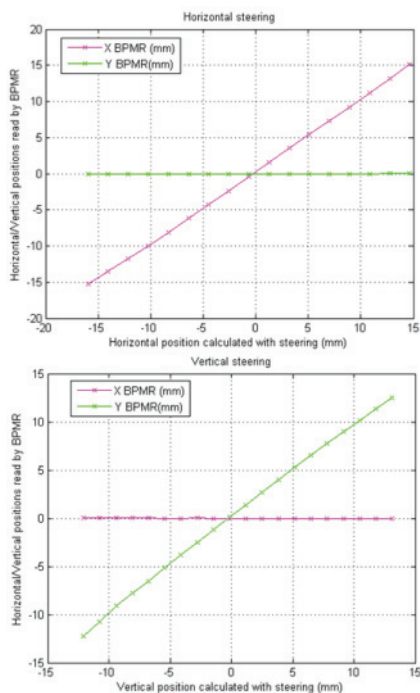

Figure 7: Calibration results from horizontal (top) and vertical (down) steerings with a charge around 0.4 nC at FLASH2.

Figure 8 illustrates the beam position as a function of charge. Here changing the charge by $\pm 5\%$, the beam position does not change within $< 100 \mu\text{m}$.

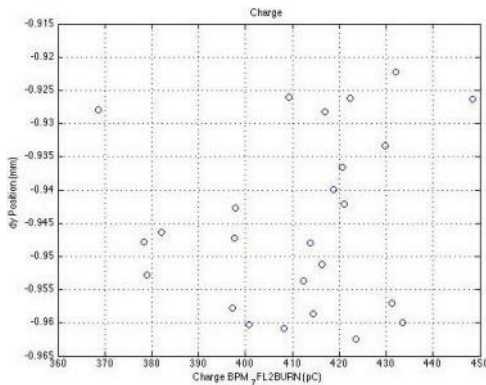

Figure 8: Position read by reentrant BPM installed at FLASH2 vs charge read by the reentrant BPM.

Resolution

Some resolution measurements were done with reentrant BPMs installed on the FLASH2 linac and E-XFEL injector. Two different configurations can be used: one with no amplifier (direct path) used for high charges and one with one amplifier used for the low charges. To cancel the beam jitter, the reentrant BPM resolution is measured by correlating the reading of the reentrant BPM in one plane against the readings of all other BPMs in the same plane [9]. Table 2 presents the resolution measurements. These resolution measurements were done, for the “direct path”, with a dynamic range of $\pm 10 \text{ mm}$ at 1 nC.

Table 2: Reentrant BPM Resolution Measurements

Beam charge (pC)	Machine	Configuration	Resolution (μm)
450	FLASH2	“Direct path”	~ 5
100	FLASH2	“Direct path”	~ 7
30	FLASH2	“Amplifier”	~ 10
500	E-XFEL	“Direct path”	~ 5
100	E-XFEL	“Amplifier”	~ 4
50	E-XFEL	“Direct path”	~ 30
50	E-XFEL	“Amplifier”	~ 8

CONCLUSION

Beam tests done at the FLASH2 linac and at the E-XFEL injector showed that the specifications like linearity, dynamic range and resolution for the E-XFEL cold reentrant BPM are fulfilled. These measurements, also, allow qualifying a calibration procedure to minimize the difference between the predicted and measured values.

ACKNOWLEDGEMENT

We thank our colleagues from CEA Saclay, DESY and M. Stadler from PSI for their contribution, their support, and their advice during the development of this project. We also acknowledge the operators and support teams for their help during the measurements done on the FLASH2 linac and the E-XFEL Injector.

REFERENCES

- [1] R. Brinkmann, “The European XFEL Project”, Proc. *FEL2006*, Berlin, Germany, 2006.
- [2] D. Treyer *et al.*, “Design and beam test results of button BPMs for the European XFEL”, *IBIC2013*, Oxford, UK, 2013.
- [3] N. Baboi, D.Noelle, “Commissioning of the FLASH2 Electron Beam Diagnostics in respect to its use at the European XFEL” *IBIC2014*, Monterrey, CA, USA, 2014.
- [4] F. Brinker, “Commissioning of the European XFEL injector”, *IPAC2016*, Busan, Korean, 2016.
- [5] C. Simon *et al.*, “Fabrication Process for the European XFEL re-entrant cavity BPM”, *IBIC 2014*, Monterrey, CA, USA, 2014.
- [6] B. Keil *et al.*, “A Generic BPM Electronics Platform for European XFEL, SwissFEL and SLS”, *IBIC14*, Monterrey, CA, USA, 2014.
- [7] C. Simon, *et al.*, “Performance of a reentrant cavity beam position monitor”, Physical review special topics – accelerators and beams 11, 082802 (2008).
- [8] B. Keil *et al.*, “Beam-based calibration and performance optimization of cavity BPMs for swissFEL, E-XFEL and FLASH2”, Proceedings. *IBIC2014*, Monterrey, CA, USA, 2014.
- [9] N. Baboi *et al.*, in Proceedings of the *12th Beam Instrumentation Workshop (BIW2006)*, Batavia, IL, 2006, *AIP Conf. Proc. No. 868* (AIP, Batavia, IL, 2006), <http://dx.doi.org/10.1063/1.2401409>