

STABLE TRANSMISSION OF RF SIGNALS AND TIMING EVENTS WITH ACCURACY AT FEMTOSECONDS

M. Liu*, X. L. Dai, C. X. Yin, SINAP, Shanghai, China

Abstract

We present a new design of femtosecond timing system. In the system, the RF signal and timing events are transmitted synchronously in one single optic-fibre with very high accuracy. Based on the theory of Michelson interferometer, the phase drift is detected with accuracy at femtoseconds. And phase compensation is accomplished at the transmitter with two approaches afterwards. Moreover, the traditional event timing system is integrated into the new system to further reduce the jitter of timing triggers. The system could be applied in synchrotron light sources, free electron lasers and colliders, where distribution of highly stable timing information is required. The physics design and the preliminary results are demonstrated in the paper.

INTRODUCTION

Timing information with high precision is required to synchronize devices and equipments in large accelerator facilities. The SINAP timing system, as one of the traditional event timing systems, distributes triggers and clocks with jitter at picoseconds.^[1] The delay and width step of the timing signals is in different levels from picoseconds to nanoseconds.^[2] The SINAP timing system is successfully applied in Pohang Light Source II^{[3][4]}, Shanghai Synchrotron Radiation Facility, Beijing Electron-Positron Collider II, SuperKEKB^[5], Chinese Spallation Neutron Source, Brazil Sirius Light Source, Shanghai Advanced Proton Therapy Facility^[6] and so on.

However, the traditional event timing system can't meet the requirement of new experiment methodology like pump-probe technology in the third generation light sources. Moreover, the synchronization of electron gun, lasers and experiment equipment in the fourth generation light sources, free electron lasers, demands higher accuracy. A level of 10-100 femtoseconds should be achieved for the accuracy of the triggers and clocks.

Laser modules but not electronic ones are mainly utilized to form the new highly stable timing system. One technical route makes use of mode locked laser as the reference base, and detects the variation of the transmission delay by the technique of balanced cross-correlation, and compensates the delay with optical feedback methods.^[7] The other technical route makes use

of continuous wave laser as the reference base, and detects the variation of the transmission delay by the theory of Michelson interference, and compensates the delay with electronic feedback method.^[8]

We designed the system, which is based on the theory of the Michelson interference. The RF signal is modulated in continuous wave laser carrier. The phase drift of laser carrier is detected by sensing the phase of the beat frequency signal, which increases the measuring precision remarkably. The phase drift is compensated by optical approaches. The system aims to stabilize the phase of transmitted RF signal to 0.01° . The traditional event timing system is integrated to transmit event stream in the same fibre, from which the timing triggers benefit to decrease the original jitter.

SYSTEM DESIGN

The detection and compensation of the phase drift is accomplished at the transmitter side. Therefore, the transmitter is much more complex than the receiver. Such design improves the scalability and reduces the cost for large systems.

The transmitter of the system is divided into the optical part and the electronic part. A collection of available commercial modules is utilized to form the optical part, which is primarily the Michelson interferometer. The core modules are the continuous wave laser, the analog modulator, the acousto-optic frequency shifter and the optical delay modules. The RF signal is modulated in continuous wave laser carrier. The photodiode receives the beat frequency signal by heterodyne interference. An optical delay line and a fibre stretcher compensate the drift along the fibre.

The phase drift caused by ambient temperature change is sensed in the electronic part, and then the optical path variation is calculated and is used to control optical delay modules. A wavelength division multiplexer multiplexes the event stream and modulated RF signal onto one single fibre.

The receiver of the system is less complex. It reflects the optical wave as one arm of the Michelson interferometer, recovers the RF signal and event codes.

The structure of the system is illustrated in Fig. 1.

*liuming@sinap.ac.cn

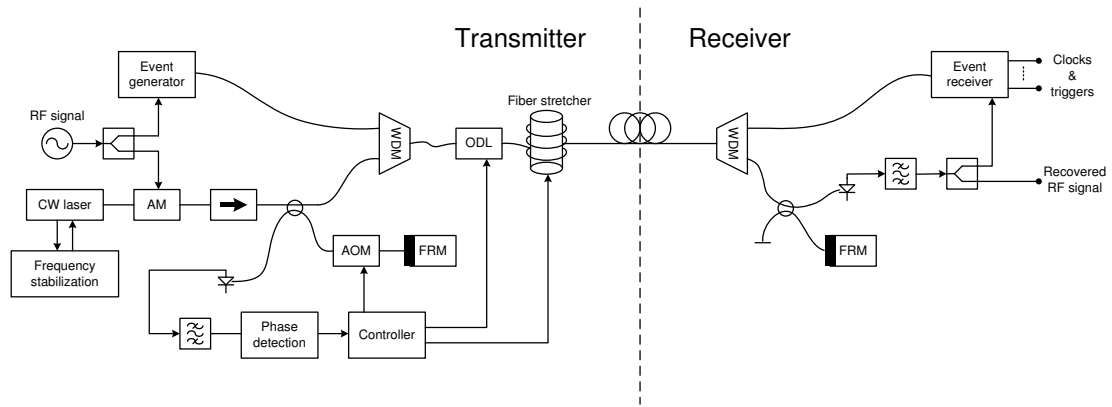

Figure.1: The structure of the system.

Signal Modulation and Transmission

It is assumed that the fibre laser generates ideal monochromatic light. The RF signal modulates the optical wave. The modulated signal

$$E_{AM}(t) = [1 + b \cos \omega_{rf} t] \cos \omega_{op} t, \quad (1)$$

where ω_{rf} is the angular frequency of the RF signal, ω_{op} is the angular frequency of the optical wave, and b is the modulation index. The RF waveform determines the envelope of the optical carrier. The photodiode at the receiver side recovers the RF signal.

When the change of the ambient temperature occurs, the refractive index variation of the fibre contributes most to the phase drift of the recovered RF signal. It is approximately 30 picosecond/ $^{\circ}\text{C}/\text{km}$.

Phase Drift Detection and Correction

The system makes use of the theory of Michelson interference to detect the phase drift. One arm of the interferometer is the modulated laser signal passing through the acousto-optic frequency shifter twice and reflected at the transmitter. The other arm of the interferometer is the modulated laser signal reflected from the receiver to the transmitter. The photodiode at the transmitter receives the beat frequency signal. After neglecting the small quantity of the phase and filtering the DC and high-frequency components, the output of the photodiode

$$I_d = \cos \left(2\omega_{fs} t + \frac{2\omega_{op} l}{c} n \right), \quad (2)$$

where ω_{fs} is the angular frequency of the acousto-optic frequency shifter, l is the length of the fibre from the transmitter to the receiver, and n is the refractive index of the fibre.

According to Equation (2), the phase of the laser carrier at the receiver is converted one-to-one to the phase of acousto-optic frequency. Since the frequency of the acousto-optic frequency shifter is 10^{-6} lower than the laser carrier, the method of the heterodyne interference improves the measuring precision effectively.

The electronic part at the transmitter acquires the phase drift and sends the controlled quantities to the motorized variable optical delay line and the optic fibre stretcher to

correct the phase drift of the fibre coarsely and finely respectively.

Transmission of Event Stream and RF Clock in One Fibre

The traditional timing system is integrated to the system so as to transmit low-precision and high-precision signals to different types of equipments in the large accelerator facility.

The RF signal is modulated in the laser carrier of 1560nm, while the event stream is modulated in the laser carrier of 1310nm. The WDM at the transmitter makes it possible to deliver the two signals in one fibre. And then the WDM at the receiver conducts the demultiplex and separates the two signals. Therefore, in one fibre optic network, both of event stream and stabilized RF signal can be distributed.

At the receiver of the system, the phase-compensated RF signal can be used to align the recovered event codes. The temperature drift effect of the fibre to the triggers and the clocks is eliminated. However, the contribution of electronics noise to the jitter still exists.

PRELIMINARY TEST

We made use of Tektronix TDS694C oscilloscope and Agilent E4440A spectrum analyzer to measure the recovered RF signal and the beat frequency signal of the optical prototype of the system qualitatively. The test bench is illustrated in Fig. 2.

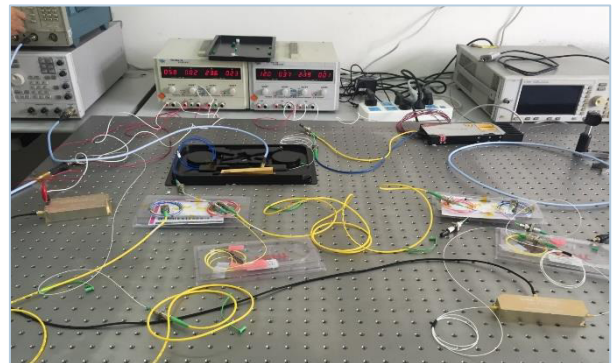

Figure 2: The prototype of the optical system.

The wavelength of the continuous wave laser is 1560nm. The frequency of the RF signal is 2856MHz. The frequency of the acousto-optic frequency shifter is 50MHz, so the frequency of the beat wave is 100MHz.

The frequency spectrum of the recovered RF signal at the receiver is illustrated in Fig. 3. A band-pass filter will be necessary to stop the DC component and the higher harmonics.

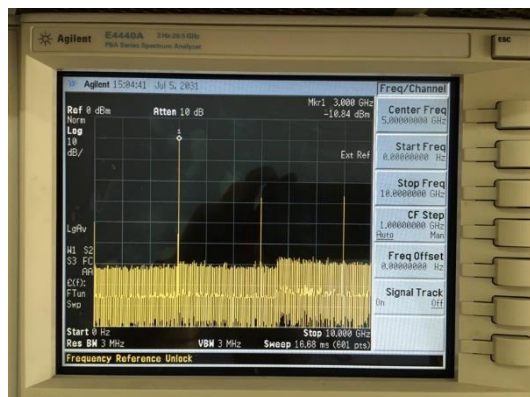

Figure 3: The frequency spectrum of the recovered RF signal.

The waveform of the beat frequency signal at the transmitter is illustrated in Fig. 4, and the frequency spectrum of it is illustrated in Fig. 5. It is observed that the frequency of the RF signal mixed in the beat frequency signal, and the frequency spectrum confirmed it. A band-pass filter will also be necessary to stop DC and higher frequency components.

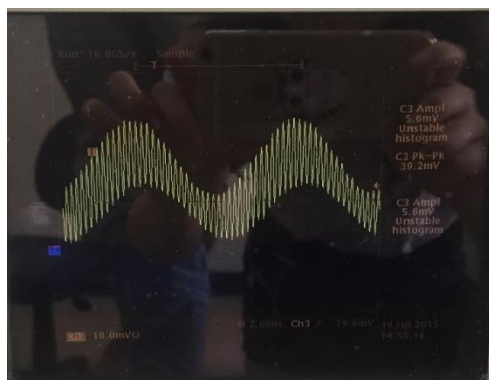

Figure 4: The waveform of the beat frequency signal.

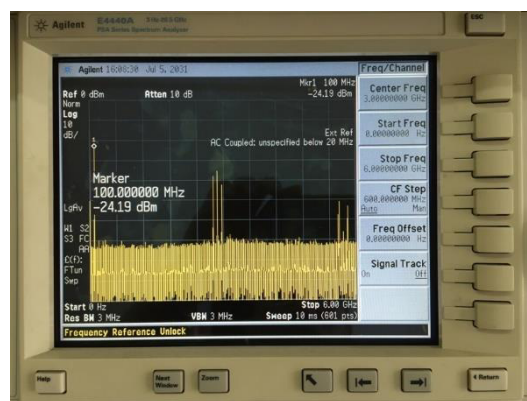

Figure 5 The frequency spectrum of the beat frequency signal.

CONCLUSION

The physics design of the system and the preliminary results of the optical prototype are described in the paper. The initial qualitative test confirmed the physics design.

The temperature change causes frequency shift of the laser. The effect also affects the phase of the recovered RF signal. We will adopt a frequency feedback device made up of a saturated absorption line to stabilize the frequency of the laser.

The ambient temperature also affects the optical components such as the acousto-optic frequency shifter and the photodiode. We will utilize a temperature control box to make the core components perform stable.

The electronic part of the system is still in the phase of hardware design. The feedback loop of phase control will be realized until the electronic part is added into the system.

ACKNOWLEDGMENT

The project was supported by the National Natural Science Foundation of China (No.11305246) and the Youth Innovation Promotion Association CAS (No. 2016238).

REFERENCES

- [1] M. Liu, "Research of a New Timing System", Doctoral Dissertation, 2010.
- [2] M. Liu, C. X. Yin, L. Y. Zhao *et al.*, Proc. of IPAC'13 (2013) 2992-2994.
- [3] S. J. Park, S. S. Park, W. H. Hwang *et al.*, Proc. of LINAC'10 (2010) 698-702.
- [4] S. Shin, S. Kwon, D-T. Kim *et al.*, Proc. of IPAC'12(2012) 1089-1091.
- [5] H. Kaji, K. Furukawa, M. Iwasaki *et al.*, Proc. of ICALEPCS'15 (2015) 629-632.
- [6] B. Q. Zhao, L. Y. Zhao, M. Liu *et al.*, Proc. of IPAC'16 (2016) 4231-4233.
- [7] J. Kim, J. Chen, Z. Zhang *et al.*, Long-term femtosecond timing link stabilization using a single-crystal balanced cross correlator. Optics Letters 32 (2007) 1044-1046.
- [8] R. Wilcox, J. M. Byrd, L. Doolittle *et al.*, Proc. of IPAC'10 (2013) 1399-1401.