

WIRE TEST OF LARGE TYPE BPM FOR P2DT IN RAON

J. W. Kwon[†], Y. S. Chung, G. D. Kim, H. J. Woo, E. H. Lim¹

Institute for Basic Science, Daejeon 34000, Korea

¹also at Department of Accelerator Science, Korea University, Sejong, 30019, Korea

Abstract

RAON (Rare isotope accelerator complex for On-line experiments) is accelerator to accelerate heavy ion such as uranium, oxygen, and proton. At P2DT(Post to Driver linac Transport line) section where is located between SCL3 and SCL2, particle beam would be higher charge state by stripper. In bending area in P2DT, BPM(Beam Position Monitor) should accept the beam that has large size (~10 cm) horizontally. Required BPM transverse position resolution is 150 μm . We simulated Large type BPM with CST particle studio. Fabricated LBPM was tested on the developed wire test bench that could move BPM for width of ± 80 mm, height of ± 40 mm with manual steering knob.

INTRODUCTION

Rare isotope Accelerator complex for ON-line experiments (RAON) include of superconducting linear accelerators, which comprise superconducting linac2 (SCL2) and superconducting linac 3 (SCL3) sections [1]. The extracted beam from ECR ion source of injector will be accelerated and transferred from SCL3 to SCL2 through P2DT section. The layout of the post linac to driver linac transport (P2DT) section of RAON is depicted in Fig.1. In the P2DT section, the charge state of the beam is changed to a higher charge state by charge stripper using carbon foil, and only the beam of a specific charge is transmitted by the Charge Selector. The beam selected by the charge selector is transmitted and accelerated to the experimental area through SCL2.

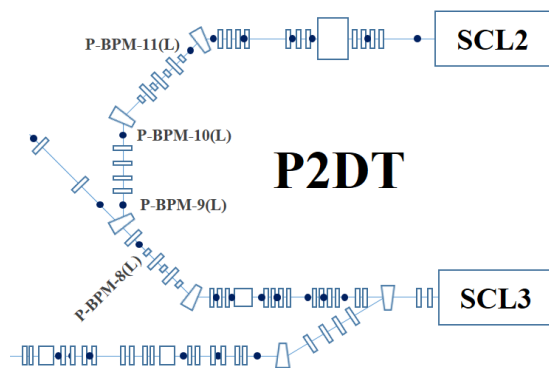

Figure 1: Layout of P2DT section of RAON, there are 4 large type BPMs for only P2DT section.

The P2DT section has four dipole magnets and 2 charge selector, which are used to select the design charge state for

[†] jangwonk@ibs.re.kr

acceleration in the SCL2. As the beam passes through the charge stripper, particle beam has higher charge state and charge selector has a role of collimator to pass the beam that has charge state between 77+ and 81+.

In the P2DT region, the energy, and bunch length of a uranium beam are 18.5 MeV/u and 0.3 ns rms, respectively. The designed input beam pulse current of P2DT is 340 μA , and the output beam current is 660 μA

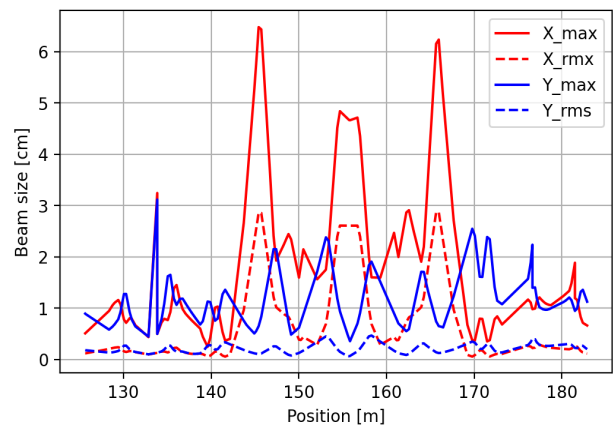

Figure 2: Beam size in P2DT section.

As the particle beam passes through a dipole magnet, the beam size increases horizontally. The increased beam size caused by multi charge state is greater than for single charge state beams. It is caused by different A/Q for same dipole magnetic field.

In the case of a uranium beam, the maximum beam size along the horizontal direction is greater than 6 cm after passing the first dipole magnet as depicted in Fig. 2. Four BPMs will be installed at the bending areas, which are placed between the four dipole magnets. The BPMs are required to accept large-size beams for measuring the positions and phases of the beams. For the bending areas where the BPMs are installed, the BPMs can be damaged because dipole magnet failure. Although MPS(machine protection system) is configured, we fundamentally want to avoid direct damage to the BPM electrode. In case of dipole magnet failure, an accelerating particle beam will hit the BPM electrode. The electrode of BPM has low heat capacity and the only place to dissipate heat is brazed feedthrough.

The required transverse position resolution is 150 μm at 81.25 MHz, that is the fundamental RF frequency and bunch repetition rate of the RAON. The formula of Δ/Σ will be used to calculate the position on the basis of the signal strength of BPM. We prepared an electronic system to calculate the signal strength and phase of all electrodes using the IQ method of 81.25 MHz [2]. BPM pickup signals were simulated using CST Particle Studio [3].

Content from this work may be used under the terms of the CC BY 3.0 licence (© 2021). Any distribution of this work must maintain attribution to the author(s), title of the work, publisher, and DOI

DESIGN AND FABRICATION OF LARGE TYPE BPM

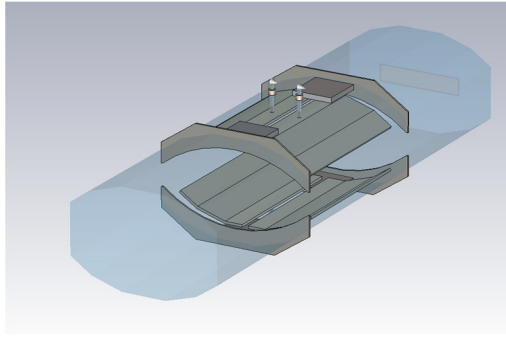

Figure 3: Design of large type BPM for CST simulation.

Two major design issues were considered while designing the BPM. First, the side regions were removed to avoid electrode damage due to machine failure. Second, the electrode plate was configured to have as high a signal strength of 81.25 MHz as possible. In Fig. 3, we depict the design while considering the design issues. A bent electrode shape was chosen to solve the design issues.

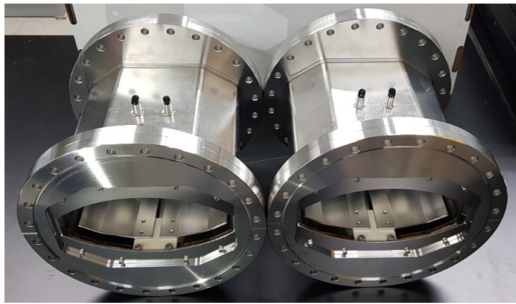
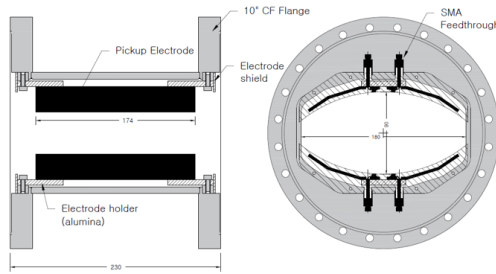

Figure 4: Drawing and fabricated of large type BPM.

The designed BPM has four large electrodes and four small feedthroughs. Ceramic parts are required to support the large plate to avoid overloading in the feedthrough. The fabricated large type BPM is depicted in Fig. 4. The rectangular bent electrode is bolted to special parts that were welded with Kyocera SMA-R feedthrough. The housing, electrode, collimator, and flange were fabricated using 316L stainless steel, which is a non-magnetic material. Alumina ceramic components were assembled to insulate and hold the electrodes.

WIRE TEST OF LARGE TYPE BPM

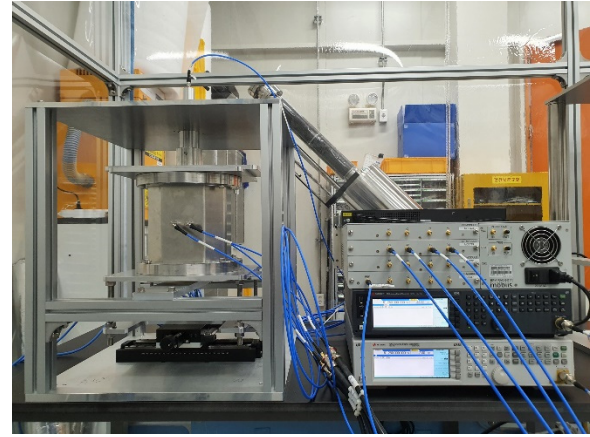

Figure 5: Setting of Wire test bench.

Wire test is a simple way to check the BPM performance without real beam. The developed wire test stand includes a stretched wire that can be installed through the BPM and a movable bench for 2D planes, as shown in Fig. 5. The wire test bench has the 2 movable stage for X and Y axis and it could move BPM for width of ± 80 mm, height of ± 40 mm with manual steering knob. The minimum scale of the stage is $20 \mu\text{m}$ and $10 \mu\text{m}$ in the X and Y directions, respectively. The input signal on the wire is set to measure the signal strength at the feedthrough of the BPM, which corresponds to a current of $300 \mu\text{A}$. The case of a beam passing through the center of the beam pipe was simulated using the CST particle studio, and the component of 81.25 MHz was calculated as a value of -32dBm.

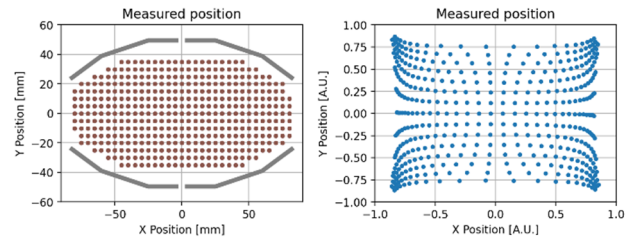

Figure 6: Measured position, (a)left : red dots show real wire positions, grey line show electrode plate (b)right : blue dots show measured positions of BPM electronics.

The wire test was performed on an area that was as wide as possible measurable as shown in Fig. 6(a). The measured position with developed BPM electronics is depicted in Fig. 6(b). The measured position X_0, Y_0 have a value range of ± 1 [4]. Calibration factors is required to correct the position in mm dimension of the actual position. There are few calibration methods for BPM such as 1D linear, 1-D polynomial, 2-D-Polynomial [4]. We choose 1-D 3th polynomial method for large type BPM as express in Eq. (1).

$$\begin{aligned}
 X_{\text{measured}} &= K_1 X_0^3 + K_2 X_0^2 + K_3 X_0^1 + K_4 X_0^0 \\
 Y_{\text{measured}} &= L_1 Y_0^3 + L_2 Y_0^2 + L_3 Y_0^1 + L_4 Y_0^0
 \end{aligned} \quad (1)$$

Calibration factors were obtained from 1-D polynomial fit with measured position results on X, Y axis. After considering the calibration factors, all the measured data can be found to be meaningful in the position dimension. Fig. 7 shows the position calibrated in mm using the 1D polynomial calibration factors.

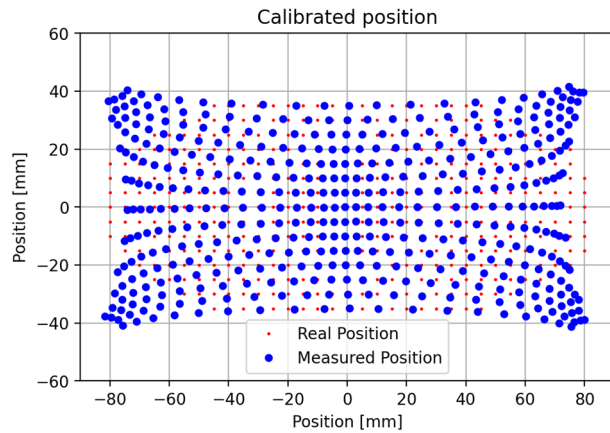

Figure 7: Calibrated position, red dots show real wire position and blue dots show calibrated position.

Figure 7 shows calibrated position with 1D 3th polynomial method. The farther the measurement position is in the X direction, the more it deviates from the actual position. This is because the closer to the electrode plate, the greater the distortion of the position measurement. And the accuracy, which means the difference in length between the actual position and the corrected position, is shown in Fig. 8. Accuracy is less than 10mm in most areas occupying a large area inside the rhombus-shaped BPM. Closer to the electrode plate, the accuracy values increase up to 30 mm.

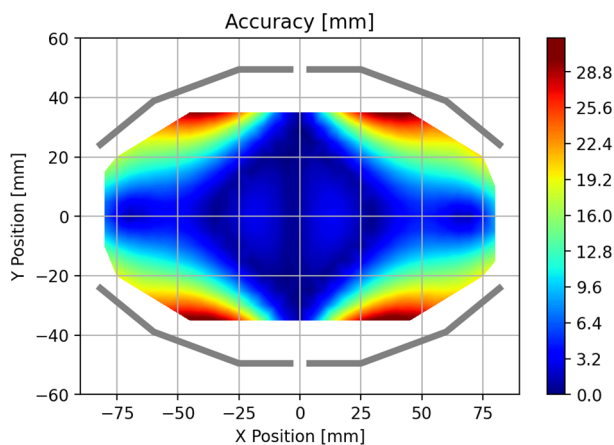

Figure 8: Accuracy in measured area.

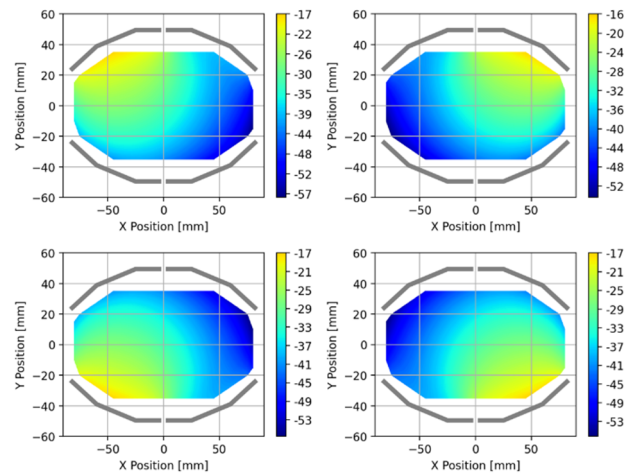

Figure 9: The amplitudes (dBm) of each measured electrode plate. Right-Up: (X-, Y+), Left-Up: (X+, Y+), Right-Down: (X-, Y-), Left-Down: (X+, Y-)

To obtain measured position 4 amplitudes is used from 4 electrode plate. The amplitudes of each measured electrode plate at the position where wire test performed is depicted in Fig. 9. Since the large type BPM has a symmetrical structure, the distribution of the measured signal strength measured on the electrode plate has a symmetrical shape. The amplitude values ranged from approximately -60dBm to -17dBm. Amplitude gain was calibrated prior to performing the BPM wire test. As the wire test results showed that the distorted area was close to the electrode plate, the strength measured near the electrode plate did not differ significantly as the position was changed. In addition, since the electrode has a diagonal direction to represent the X-Y plane, nonlinear measurement results are obtained.

CONCLUSION & DISCUSSION

To correct the beam trajectories, BPM is required to accept a large-size beam for the horizontal axis in the P2DT section. The BPM was designed to cover as much as possible and was fabricated using bent electrode plates of optimal length. We developed a wire test bench with two movable stages, ± 40 mm in X direction and ± 80 mm in Y direction with manual steering knobs. Fabricated large type BPM was performed at the wire test bench with signal strength for stretched wire corresponding to 300 μ A beam current and a narrow beam. Accuracy and signal strength were obtained at each measurement location considering the correction factor obtained from the values measured on the X-axis and Y-axis of the wire test bench. In most areas, the accuracy value was less than 10 mm, and the signal strength of -60dbm to -17dbm was measured at each electrode.

Although large BPM was tested at wire test bench, it can explain in case of very narrow beam. The beam size, current, and charge state vary in the P2DT section during beam operation. There is charge stripper to strip electron from heavy-ion particle. At that time various stripped particle ion is produced and transport to SCL2 through large type

BPM. To select charge state of particle beam, the beam size would be increased for X axis. Because BPM measures the center of charge, the measured position may change as the stripping efficiency changes. Of course, the calibrated position including calibration factor and real position measurement is differ depending various beam size.

ACKNOWLEDGMENT

This work was supported by the Rare Isotope Science Project of the Institute for Basic Science, funded by the Ministry of Science, ICT, and NRF of Korea (2013M7A1A1075764).

REFERENCE

- [1] S. K. Kim *et al.*, "Rare Isotope Science Project: Baseline Design Summary", Institute for Basic Science, Daejeon, Korea, 2012.
- [2] J. W. Kwon, H. J. Woo, G. D. Kim, Y. S. Chung, E.-S. Kim, "Beam position monitor for superconducting post-linac in RAON", *Nucl. Instrum. Methods Phys. Res. A*, vol. 908, pp. 136-142, 2018.
- [3] Computer simulation technology, <https://www.cst.com/>.
- [4] J. W. Kwon, "Development of Beam Position Monitor system for RAON heavy ion accelerator", Ph.D. Thesis, Korea University, Korea, 2020.