

PERFORMANCE OF THE REFERENCE AND TIMING SYSTEMS AT SPRING-8

Y. Ohashi, T. Asaka, H. Ego, M. Hara, Y. Kawashima, T. Ohshima, T. Takashima and
H. Yonehara, SPring-8, Hyogo 679-5198, Japan

Abstract

Reference RF and timing systems were developed at SPring-8 in order to handle beams in a stable and flexible manner under various conditions of machine operation. A synchronous universal counter plays an essential role in the timing system. Here, the method to realize high-precision timing is described, as well as the tools that were required to confirm that the system operates as designed. Furthermore, a new scheme for the synchronization of the different RF signals from linear and circular accelerators is described.

1 INTRODUCTION

The SPring-8 accelerator complex consists of an 8 GeV storage ring (SR), a booster synchrotron (SY), and a 1 GeV linac. A common master oscillator provides the 508.58 MHz RF reference signal to the SR and SY, whose harmonic numbers are 2436 and 672, respectively. The linac is operated at 2856 MHz and a repetition rate of 60 Hz. The SR is a third generation light source that provides high-brilliance synchrotron light to various experimental groups. Any kind of beam filling and refilling patterns are achievable by the successful development of a synchronous universal counter (SUC) [1] and a stable signal-transmission system.

The 508 MHz SUC must perform the following functions; 1) trace the location of the RF buckets by synchronous non-stop revolution counting, 2) act as a timing/delay pulse generator with synchronization of 508.58MHz. A SUC is widely used by the users who require precise timing relative to the beam. A phase-stabilized optic fiber (PSOF) [2] is commercially available and a temperature coefficient in the phase drift of about two orders of magnitude smaller compared to a phase-stabilized coaxial cable. In addition to that, electric-to-optic (E/O) and optic-to-electric (O/E) signal transmitters with small temperature coefficients became commercially available also. An optic signal-transmission system has the advantage over the conventional electric one with respect to phase stability. In combination with the synchronization feature of the SUC mentioned above, a high-precision timing-signal transmission system, for which time jitters are minimum and almost independent of the transmission distance and delay period, is established.

A development of reference RF and timing system was started in 1991, and its feasibility was confirmed by the end of 1993. Construction of the timing system was completed in 1996, and the system is running properly and stably since beam commissioning in March 1997.

A single-bunch beam is created from the linac beam of 1 ns width by RF knockout system installed in the SY [3]. Acceleration of a beam in a single RF bucket of 2856 MHz is desirable in order to make the single-bunch purity better. There is no simple relation between two RF frequencies of 508.58 and 2856 MHz, however, two RF signals had to be synchronized for precise beam injection. We paid attention to the fact that the linac is not operated in CW. A new scheme of synchronizing multiple RF frequencies has been implemented [4].

2 SYNCHRONOUS UNIVERSAL COUNTER

Recent digital technology made it possible to perform a direct counting at a rate of over 500 MHz for accelerator applications. The 508 MHz SUC has a capability to count up to 30 bits in order to cover 1 sec of ramping time of the SY. The circuit block diagram is shown in Fig. 1. We describe some details of the SUC used at SPring-8. Application to a different environment is simple. The SUC counts the RF bucket number corresponding to the harmonic number ($N=2435$) of the SR, and it then provides a pulse corresponding to the revolution

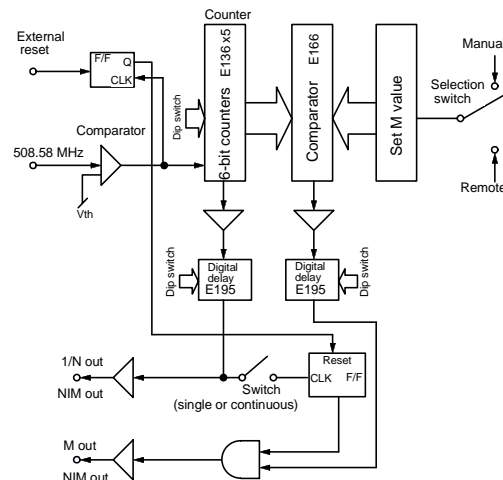

Fig. 1. Block diagram of a 508 MHz SUC.

frequency of SR from '1/N out'. The output 'M out' corresponds to the particular RF bucket within a revolution. Beams are injected into the targeted RF buckets from the SY by setting the number 'M' as desired. 'M' can be set either externally or manually. By resetting the SUC, a delayed pulse is generated from '1/N out' ('M out') with a delay time of $N(M)/508.58\text{MHz}$ in a synchronous way. The device is packaged in a single width standard NIM module, and it can be applied whenever precise timing is required.

3 REFERENCE AND TIMING SIGNAL DISTRIBUTIONS

An optic signal-transmission system was adopted where phase/timing precision is crucial. Proper methods to distribute the signals were selected in consideration of the environmental factors. There are two ways to distribute the reference RF signal to the four RF control stations; 1) sequential transmission from station to station relying on the phase-locked-loop (PLL) feedback system between two stations, 2) single loop with optic directional couplers around the SR with a single PLL feedback between transmitted and returned signals. The SR-building is kept at a steady temperature of $25\pm 1^\circ\text{C}$ by air conditioning to meet with the strict experimental requirements from synchrotron-light-source users. Because of the excellent phase stability of the PSOF, we selected the latter method (Fig. 2), also because of the fact that the sequential use of PLL feedback piles up phase errors. On the other hand, we introduced a different method for the signal distribution to the injectors, since temperature along the fiber path of $\sim 700\text{ m}$ is not controlled as well as in the SR case. A PLL feedback, using the signal returned in the

same optic fiber reflected by the mirror located at the end point was applied [5].

Devices used for the timing-signal distribution are similar to the ones used for the reference RF signal. Time jitters due to the unstable output pulse amplitude from the E/O module are compensated by inserting a constant fraction discriminator (CFD). A more precise timing signal is delivered by synchronizing it with a reference RF signal in the place where precision is required. This is simply realized by introducing a signal concerned into the input 'External reset' of the SUC. Timing precision is restored to a few ps. Annual drift in the reference RF phase is about 5 degrees in the SR and 3 degrees in the SY without PLL feedback control. They become within 1 degree with PLL feedback control. Time jitters in the timing pulse transmission without synchronization vary depending on the system. For example, it was measured to be 7.4 ps (standard deviation) in the electron gun system of the linac [1].

4 PERFORMANCES

There are several ways to check the stability of the reference RF and timing system.

- 1) A picosecond pulsed laser used in a time-resolved experiment must inject laser beam in a sample exactly when synchrotron light beam hits the sample. Timing between the two beams was measured using a streak camera. A stability of $\pm 2\text{ ps}$ was obtained for a few hours [6].
- 2) Impurity level of a single-bunch beam was measured in the SR and was less than 10^{-9} (below detection level) over several hours [7]. Reduced beam current during user experiment period is restored by the beam refills.
- 3) The beam orbit deviates due to the tidal forces. The beam energy shifts due to changes in the circumference of the SR caused by the deformation of the ground. The beam orbit correction system compensates such deviations, and it results in a shift of the RF frequency. Maximum peak-to-peak variation of about $70\text{ }\mu\text{m}$ in the circumference is properly corrected, where the correction step is currently set to $0.3\text{ }\mu\text{m}$ [8].

5 NEW SYNCHRONIZATION SCHEME BETWEEN TWO RF'S

A simple way to synchronize two RF frequencies is to generate those RF frequencies from a common sub-harmonic oscillator together with frequency dividers/multipliers. Although this method should in principle be applicable, a compromise between hardware availability and performance has to be found. Since a conventional method was not applicable to the SPring-8, a new idea was sought by freeing the constraint between two RF's required for synchronization. A 2856 MHz RF is actively used for a short period that corresponds to a small duty

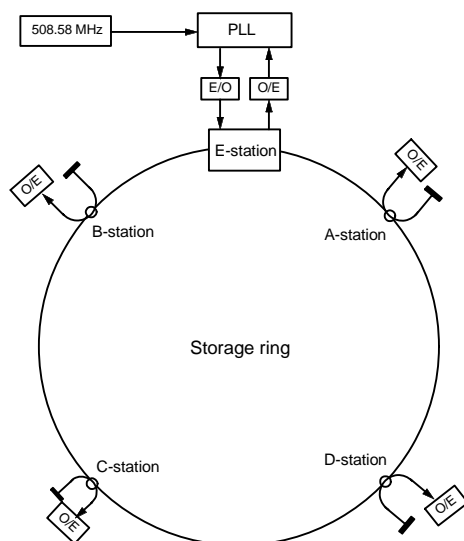

Fig. 2. Reference RF signal distribution for the storage ring.

factor of the linac. When the beam injection takes place, a pulse synchronized with 508.58 MHz triggers the 2856 MHz generation each time. Fig. 3 shows the block diagram of the new synchronization method [4]. The 2856 MHz RF generator is simple and consists of an arbitrary waveform generator (AWG), bandpass filters, and a frequency multiplier. The numbers in Fig. 3 indicate the current parameter setting. The duration of 2856 MHz generation is 290 μ s. The spectra from the synthesizer and the present device are shown in Fig. 4. The difference of 18.7 kHz is small enough and does not affect practical operations. Suppression of time jitters in the 'start signal' in Fig.3 is essential to obtain a high precision synchronization of the two RF signals, and it is realized by using the SUC. Only one master synthesizer of 508.58 MHz is present after elimination of the one in the linac. The method described here can be applied widely and easily to similar facilities. One can choose the best RF components suited for the project without caring about their frequencies any more.

6 CONCLUSIONS

The SUC is a key tool in the SPring-8 timing system for flexible beam handling. It gives the revolution and RF bucket information with small time jitters. The reference RF signal distribution system was successfully constructed using PSOF, E/O and O/E with small temperature coefficient and time jitters. Annual phase drift is within 1 degree by a PLL feedback. A timing signal distribution system, which requires extremely small

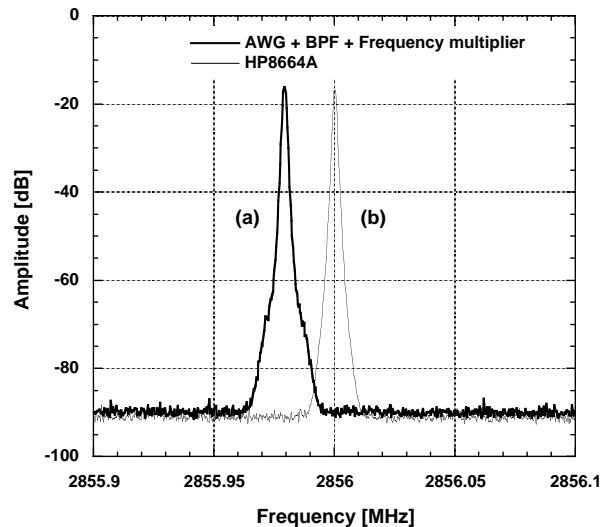

Figure 4: Spectra of 2856 MHz RF's: (a) generated by the new method; (b) generated by a synthesizer.

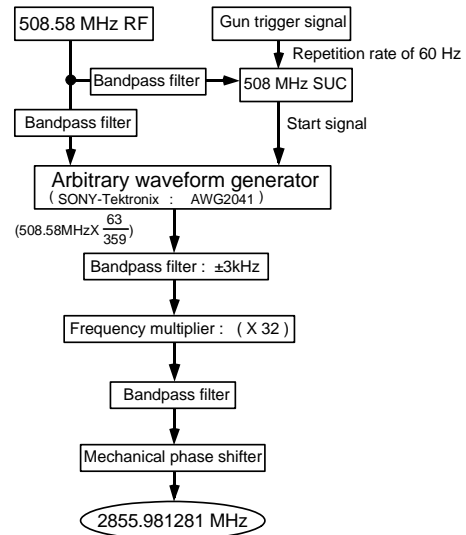

Fig. 3. Block diagram of the new synchronization method between 508.58 and 2856 MHz RF's. The system consists of an arbitrary waveform generator and a frequency multiplier. The 2856 MHz RF is generated only for a short duration of about 290 μ s.

time jitters, was constructed by using the synchronization function of the SUC, and it is thus less sensitive to the transmission distance or delay. A new synchronization system for two different RF's performed well. We now have only one synthesizer as a master in the SPring-8 accelerator complex. Application of the tools and systems described in this paper is simple to other facilities.

REFERENCES

- [1] H. Suzuki *et al.*, Nucl. Ins. Meth. A 431, 294-305 (1999).
- [2] J. Urakawa, Particle Accelerators, 1990, Vol.29, pp.251-256.
- [3] H. Suzuki *et al.*, Nucl. Ins. Meth. A 434, 515-533 (2000).
- [4] Y. Kawashima *et al.*, Phys. Rev. ST Accel. Beams Vol.4, 082001, 1-5 (2001).
- [5] E. Peschardt and J.P.H. Sladen, IEEE, 1989, pp. 1960-1962.
- [6] Y. Tanaka *et al.*, Rev. Sci. Ins. 71, 1268-1274 (2000).
- [7] K. Tamura, Proc. of the 12th symposium on Accel. Sci. & Tech., Wako, Japan, 1999, pp. 546-548.
- [8] S. Daté and N. Kumagai, Nucl. Ins. Meth. A 421, 417-422 (1999).