

VME SWITCH FOR CERN'S PS ANALOG VIDEO SYSTEM

J. Serrano, I. Acebes, S. Deghaye, W. Heinze, J. Lewis, CERN, Geneva, Switzerland

Abstract

Analog video signal switching is used in CERN's Proton Synchrotron (PS) complex to route the video signals coming from Beam Diagnostics systems to the Meyrin Control Room (MCR). Traditionally, this has been done with custom electromechanical relay-based cards controlled serially via CAMAC crates. In order to improve the robustness and maintainability of the system, while keeping it analog to preserve the low latency, a VME card based on Analog Devices' AD8116 analog matrix chip has been developed. Video signals go into the front panel and exit the switch through the P2 connector of the VME backplane. The module is a 16 input, 32 output matrix. Larger matrices can be built using more modules and bussing their outputs together, thanks to the high impedance feature of the AD8116. Another VME module takes the selected signals from the P2 connector and performs automatic gain to send them at nominal output level through its front panel. This paper discusses both designs and presents experimental test results.

INTRODUCTION

Operators in the Meyrin Control Room (MCR) use video signals extensively for diagnostics and beam steering purposes. Most of these signals come from cameras pointing at movable screens interposed in the beam trajectory and placed in various places along the different accelerators. This destructive diagnostic is very convenient for setting up and checking beams. In the past, distributed analogue matrices made with electromechanical relays [1] were used to switch the video signals from producers to consumers. With time, the maintenance of this system became more and more costly, as the relays started to wear off and fail more often. Also, the software used to control the matrices was very difficult to update in order to accommodate new operator requests. It was therefore decided to update the whole system both in hardware and software.

After a survey of commercial digital solutions, it was decided to develop a new analogue system at CERN. The main reason was that analogue systems ensure minimal latency between the video source and the monitors. This is of critical importance for operators in the MCR since they have other visual references to correlate with the video signals. Digital systems take some time to compress the video stream at the source and decompress it at the destination. In addition, commercial systems offer features for which we have no need but which increase their price significantly. A final reason was that an analogue system allows us to perform a smooth transition between the old system and the new one.

In order to easily integrate the new system into the PS Control System, it was decided to change the form factor of the modules from CAMAC to VME, and also to

rewrite the application program in Java using PS standard communication mechanisms with the LynxOS front ends. In the following paragraphs we describe both the hardware and software developed.

HARDWARE

Two VME modules have been developed within the frame of this project. One is a 16-input, 32-output analogue video matrix. The 16 inputs come in differential form through a flat cable connector in the front panel, while the 32 outputs are connected to the user-defined pins of the VME backplane P2 connector. Thanks to the tri-state feature in the module's outputs, it is easy to generate bigger matrices by using two or more modules side by side and bridging their respective P2 ports with a flat cable. Thus a 32x32 matrix can be generated with two modules, a 48x32 matrix with three and so on.

A second module takes the signals from the P2 connector and amplifies/attenuates them to automatically reach a nominal voltage of 1 Vpp at its output. The signals are then sent through cable drivers to front panel lemo 00 coaxial connectors.

The Video Matrix Module

Figure 1 depicts the overall architecture of the Video Matrix module.

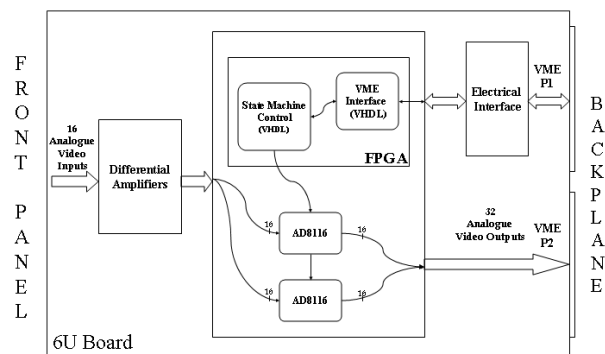

Figure 1: Overview of the Video Matrix module.

The differential amplifiers can withstand a common mode voltage of $\pm 5V$. This allows for offset voltages in the video signals coming from different buildings and protects the analogue matrix chips in case of severe over voltage. The two AD8116 [2] analogue video matrix chips are configured by the VME bus master through an FPGA. The role of the FPGA is to translate the 16 bit words written from the VME to a serial configuration consisting of 90 bits. Since the inputs of the matrix chips are tied together, the result is a 16x32 full matrix. Besides, thanks to the output buffers in the AD8116, a single input signal can be connected to many outputs without experiencing any loading effects. The details of the configuration

mechanism are hidden from the user by a LynxOS device driver and a C interface library.

A Bode plot representing a real measurement of the frequency response of the card can be seen in figure 2.

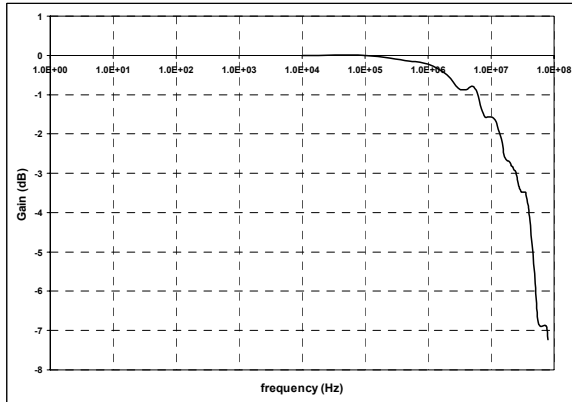

Figure 2: Frequency response of the Video Matrix card.

Even with the attenuation caused at high frequencies by the flat cable assembly in the P2 connector, the card features 25 MHz of 3dB bandwidth, far above the 5 MHz needed for base band video signals.

The Automatic Gain Amplifier

Figure 3 shows a monitor and the test video signal going into its input.

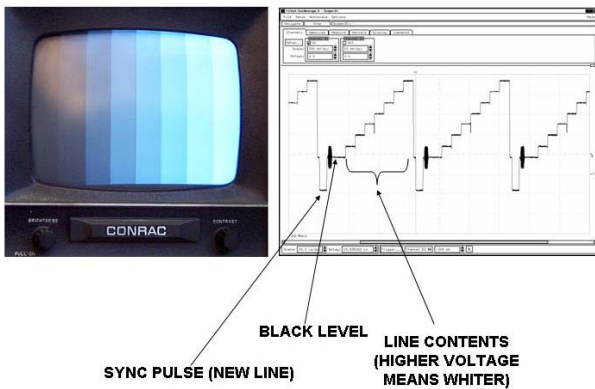

Figure 3: A test video signal as seen on a monitor and on an oscilloscope.

Although we have chosen a black and white signal for the sake of clearness, all the concepts used in this paper apply equally to colour video signals. On the oscilloscope screenshot, we can easily distinguish the negative-going sync pulses representing the new lines. These are always followed by a “back porch” representing the black level. Any voltage higher than that will represent some shade of grey, with white being the highest possible voltage. Because we cannot rely on the video contents themselves, the only solution to achieve automatic gain and therefore account for cable-induced attenuation is to ensure that the difference between the sync level and the black level is the nominal 0.3V. In order to achieve this, our card uses a sync detector IC to drive the control pin of a sample-and-hold. By sampling the amplitude of the video signal

during the back porch, we can drive a feedback loop that will increase the gain of the amplifier if the sampled value is below 0.3V. Conversely, if the value is above 0.3V, the gain will decrease. This system will not work unless the video signal is clamped so that the sync level sits at exactly 0V, which we do with a DC restore IC. In addition, the signal issued by the sample-and-hold is not directly fed to the gain control circuit, but rather smoothed through an integrator to avoid instabilities caused by too fast a loop response.

The Video Amplifier card features 32 automatic gain amplifier channels in a 6U VME card. The inputs come from the VME P2 connector user-defined pins and the outputs leave the module through lemo 00 coaxial connectors on the front panel. AD8079 video buffers are used to drive the coaxial cables between the switching system and the consumers in the MCR.

Automatic gain control ensures that all signals reach the MCR at the nominal voltage, regardless of the cable losses from their sources, therefore avoiding tedious contrast and brightness corrections on individual signals in every monitor. It also allows us to mix the contents of more than one cable into a “mosaic” video signal fed to a monitor, where the monitor contrast and brightness controls affect the resultant signal as a whole and individual corrections are no longer possible.

The combination of one video matrix module and one automatic gain amplifier has been successfully tested in the Clic Test Facility 3 (CTF3) for one year.

SOFTWARE

The software that was used to control the old relay matrices was very difficult to maintain, mainly due to many years of unstructured modifications and the lack of manpower to support it properly. It was therefore decided to make the renewal of all layers of the software in the Video Observation System an integral part of the project. This involved, as mentioned above, the development of a LynxOS device driver for the Video Matrix card, and also an Equipment Module, which is an object-like abstraction of the hardware that presents a high-level interface to user application programs.

A new application program was written in Java, with maintainability in mind. The development process involved modern object oriented techniques such as use case analysis and modelling using UML.

Figure 4 depicts the result. The four buttons in the lower-left corner of the screen represent the four monitors operators use to observe video signals on a given console. They are geometrically arranged in the same way so that all the operator has to do to connect a signal to a monitor is to select the signal through the system of menus in the upper part, and then select a monitor before clicking on the “Connect” button. The system then calculates the matrix or matrices involved in the operation and sends the appropriate commands.

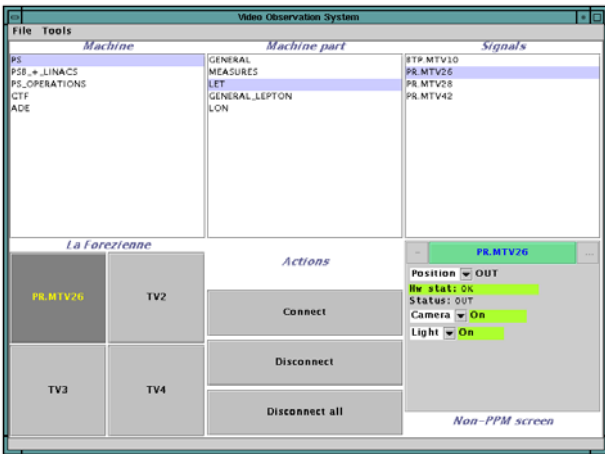

Figure 4: A snapshot of the Video Observation System GUI.

If the signal connected corresponds to a beam screen, a knob pops up in the lower-right corner to let the operator control the camera, the bulb sitting next to it and the associated stepper motors. These motors control the movement of the screens through the vacuum pipe.

The software developed for the Video Observation System is compatible with both the old and the new analogue matrix modules, a feature made possible by the Equipment Module abstraction layer. The GUI has been used successfully by operators in the MCR and other control rooms in the PS Complex for more than one year.

REFERENCES

- [1] W. Heinze “The Hardware of the Video Observation System”, CERN PS-CO Internal Note 2002-011 <http://wwwps1.cern.ch/psco/doc/notes/>
- [2] “200 MHz, 16 x 16 Buffered Video Crosspoint Switch.” See datasheet at <http://www.analog.com/>