

POWER SPECTRUM DEPENDED SPILL SERVO CONTROL BY DSP

H.Abasaki, K.Mochiki, Musashi Institute of Technology
 J.Kishiro, K.Marutsuka, H.Nakagawa, H.Sato, M.Shirakata, KEK

Abstract

A spill servo controller based on a digital signal processor (DSP) had been developed and has been used for a slow extraction at KEK 12 GeV proton synchrotron. These operations showed that the digital control system provides better spill characteristics. Based on this feasibility study a new spill servo control board has been developed. The board has a FPGA chip to calculate power spectrum of the spill signal in every few milliseconds. Using these time-dependent power spectrum more sophisticated digital control can be realized.

INTRODUCTION

KEK 12 GeV PS slow beam extraction is carried out by employing the half resonance extraction[1]. At the same time extraction Q magnet (EQ) and two ripple Q magnet (RQ) are controlled by DSP[2]. Spill beam is expected a regularly stable beam. But ripple on spill beam often increased by following active arc furnace near the KEK. Figure.1 shows the change of ripple. It turns out that ripple is increasing because an arc furnace works. Figure2 shows the comparison of frequency spectrum of the section A and B in figure1. It turns out that spectrum of about 70Hz and 130Hz is bigger than none active. We realized real time none-linear control system using it for reduce irregular ripple. We realize the following technique. First, a spectrum is calculated for the frequency of spill on real time. Then the feedback gain for EQ control and the parameter for RQ control are changed from each of that frequency spectrum. Spill irregularly generated by the above thing is controlled. After all spill servo control using frequency information of spill beam. We try to use the DSP and FPGA for slow beam extraction system because it is too easy to adjust the transfer function by changing the software itself or the parameter implemented in the software. DSP has the feature which makes highly precise operation and non-linear operation elated. Multiplication in FPGA is fast that multiplication block can be composed in parallel.

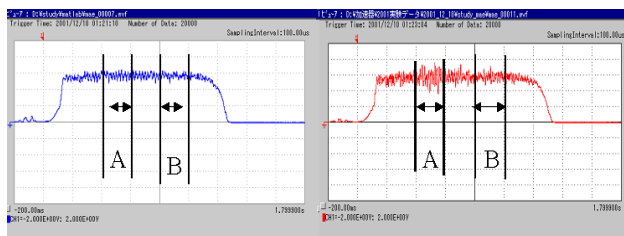
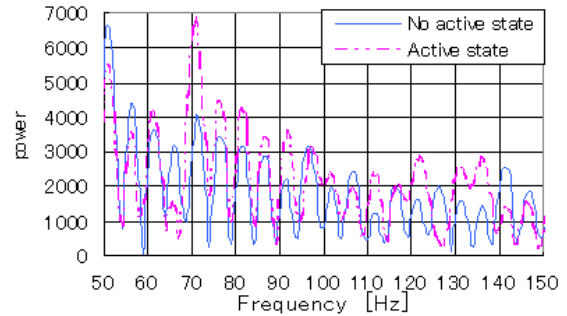
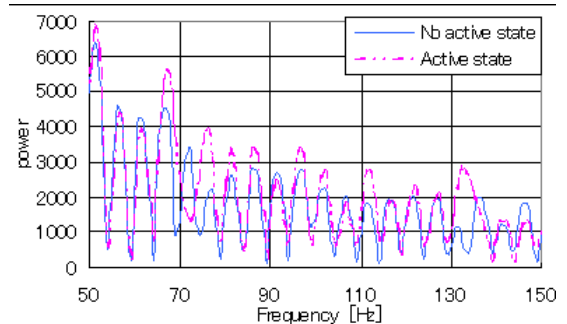

Figure 1 : Comparison of a spill signal



(a)Spectrum of part A



(b)Spectrum of part B

Figure 2: Comparison of a spectrum

SYSTEMS

Hardware

Figure 3 shows the block diagram of the developing system.

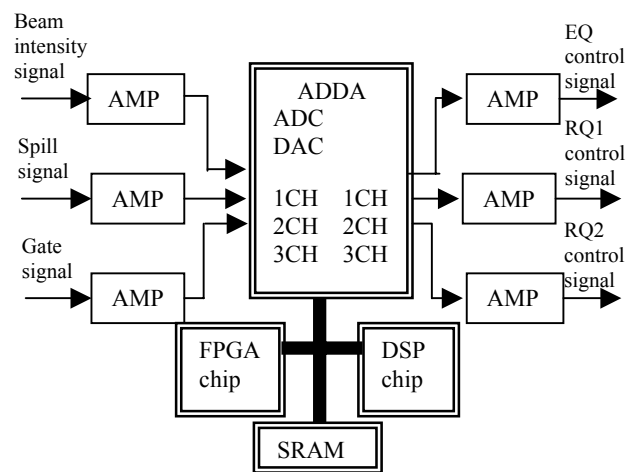

Figure 3: Improved system

The beam intensity and spill signal are amplified and adjusted its amplitude before put into the ADC. A gate signal determines a start and end of control. The response frequency of EQ is about 100Hz from a direct current.

The response frequency of RQ1 is 1kHz from 100Hz. On the other hand, RQ2 is from 1kHz to 10kHz. Each data acquisition cycle from ADC is acquired at the rate of 100kHz. For control of EQ, it controls by the rate of 50kHz. This system is equipped Motorola DSP chip and Xilinx FPGA chip with high-speed calculation. DSP calculate EQ feedback and execute digital filter. FPGA calculate spectrum.

Processing

Slow extraction is performed by cooperation of five septum magnets, four bump magnets, an octupole magnet, an EQ and two RQ[3]. Except EQ and RQ, the excitation pattern of the magnets is produced by VME computer[4]. We introduce real time frequency analysis method Power Spectrum Density (PSD)[5] in EQ and RQ control. This method is better and faster than Fast Fourier Transform (FFT). That features a sampling obtain,

Comparison with FFT

- 1, the analysis only about specific frequency is possible
- 2, analysis in the same accuracy is possible
- 3, getting specific frequency is possible in wide range
- 4, spectrum can be acquired in a short

These features show that this frequency analyzing method is suitable for high-speed control it is effective when influence appears in specific frequency. Figure 4 shows one processing unit of calculate PSD

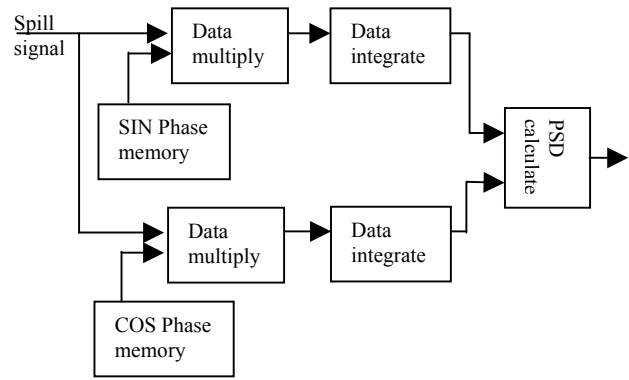

Figure 4 : PSD processing flow

The multiply and accumulation operation of the SIN and COS phase value and an input value is required for every analysis frequency. In FPGA, it calculates as follows. One analysis block is built in parallel with an inside. Then analysis is possible at high speed.

SIMULATION

Figure 5 shows result of simulation using data of 10 kilo sample per second (SPS), length 2 second and feedback control by DSP. The spectrum around 71 on 133Hz are mainly analyze. There are big influence by arc furnace. The horizontal axis of graph is time, a vertical

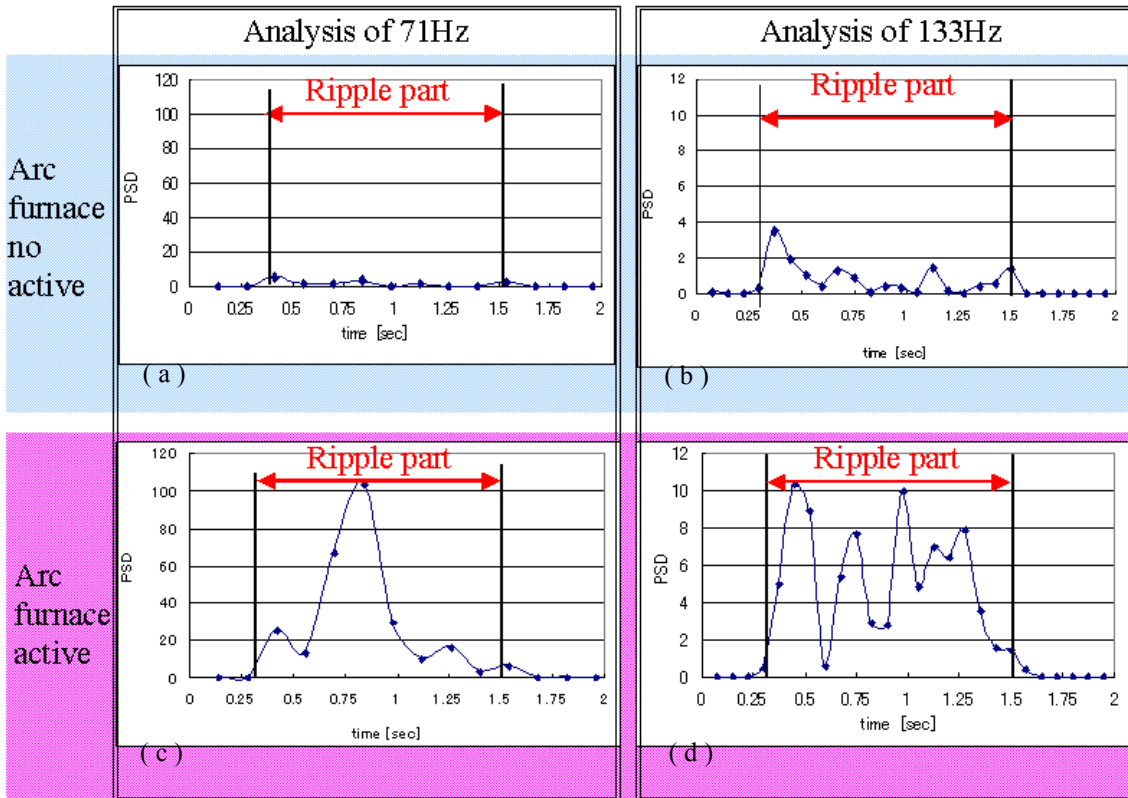

Figure 5: Result of PSD simulation

axis is the power of a spectrum. The spill signal is generated during 0.25 to 1.5 sec. Influence appears spectrum part of the stand up and falling in Fig.5. See Fig 5 (a) (c), active state is ten times larger than none active. Similarly Fig 5 (b) (d), active is two times larger than none active. System can discriminate arc furnace active. And spectrum of 133Hz Arc furnace effect spill beam ripple.

OBJECTIVES

A design and manufacture are completed and the improved digital control system is adjustment now. The noise ingredient on a beam can acquire on real time by using POWER SPECTRUM ANALYSIS. In an experiment, by using various digital filters for RQ control. Then it is made to change to the optimal digital filter one by one, and is applied to RQ magnet control. By applying POWER SPECTRUM ANALYSIS to spill, it analyzes using FFT and the spectrum of specific frequency is early obtained also for reliance. This is the difference between calculating, after carrying out fixed interval preservation of the data, and calculating for every data acquisition. This is suitable for signal analysis with a lot of low frequency, and the scene of using spectrum in control immediately. The RQ position the ring should be optimized. The filter of the optimal phase characteristic is automatically chosen from change of a spectrum in the

future. It can expect that this enabled to offset ripple more than present.

CONCLUSION

This simulation shows the possibility to control in real time non-linear spill servo control. We need to search a parameter which is effective for the digital filter of effective arc furnace by the experiment. It has high performance processor which will be able to process more complex control. We expect that phase of digital filter is considered for cancel ripple by using RQ.

REFERENCES

- [1] K.Endo, Y.Kimura, et. al., "Half integer resonance extraction from KEK-PS", Proc. of the 2nd Symp. on Acc. Sci. and Tech, 1978, p. 157.
- [2] H. Tanaka, K.Mochiki, et. al, "SPILLSERVOCONTROL BY DSP" ICALEPCS'99(1999), Trieste, Italy.
- [3] Y. Shoji, K. Marutsuka et. al., "Slow extraction system of the KEK-PS", KEK Report, 1993, p.93.
- [4] H. Nakagawa et. al., "A Program Development Tool for KEK VME-MAP Control System," Proc. ICALEPCS'91, KEK, 1992, p. 322.
- [5] Y. Murata, S. zumi, T. Sanda, "A NEW METHOD FOR DIGITAL POWER SPECTRUM ANALYSIS," Nucl. Instr. Meth. A 108 (1973) 243.