

Content from this work may be used under the terms of the CC BY 3.0 licence (© 2017). Any distribution of this work must maintain attribution to the author(s), title of the work, publisher, and DOI.

# CLARA GUN TEMPERATURE CONTROL USING OMRON PLC

A. Oates<sup>†</sup>, STFC Daresbury Laboratory, Warrington, UK.

## Abstract

STFC Daresbury Laboratory is currently commissioning Phase I of CLARA (Compact Linear Accelerator for Research and Applications), a novel FEL (Free Electron Laser) test facility focused on the generation of ultra-short photon pulses of coherent light with high levels of stability and synchronization. In order to maintain phase stability the CLARA gun requires a precision water temperature control system to maintain a gun cavity temperature within 0.028°C. This is achieved by mixing two water circuits with temperatures close to the desired set point. Two temperature measurement systems were evaluated for precision and reliability, the resultant system uses a single Omron PLC which provides all the precision read back and control loops. High resolution input modules and averaging achieve precision temperature monitoring while two PID loops control the coarse and fine temperature control. EPICS control is achieved using the FINS protocol communicating with a Linux IOC. This paper gives details of the system requirements and implementation and also describes initial results.

## CLARA

CLARA [1] is a 250 MeV, 100-400 nm FEL test facility at Daresbury Laboratory. The purpose of CLARA is to test and validate new FEL schemes in areas such as ultra-short pulse generation, temporal coherence and pulse-tailoring. Some of the schemes that can be tested at CLARA depend on a manipulating the electron beam properties with characteristic scales shorter than the electron beam and require a 30 - 50  $\mu\text{m}$  modulation of the beam energy acquired via the interaction with an infrared laser beam in a short undulator.

## CLARA GUN

Seeded FEL experiments which require interaction between a short laser pulse and the electron bunch place extremely high demands on the RF gun stability (Figure 1). For example, the jitter of the launching phase of the beam in the magnetic bunch compression mode should be less than 300 fs, which, in terms of the S-band RF phase, is 0.32°. To provide such a phase stability the required cavity peak to peak temperature stability should be better than 0.028°C. This is still below the current start-of-the-art

performance of thermal stabilisation systems which is 0.04°C [2].

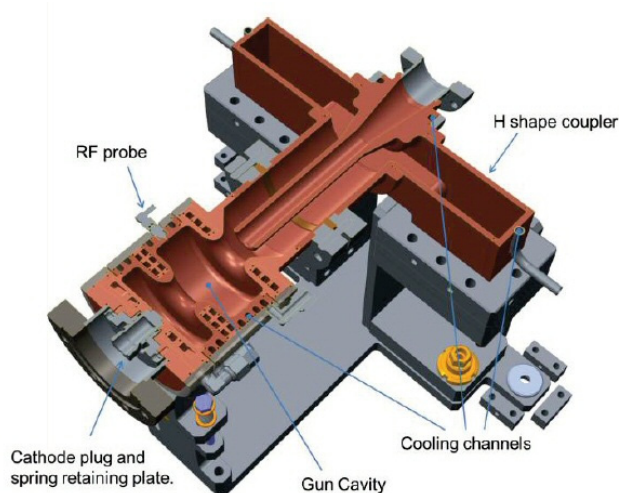

Figure 1: Overview of the gun cavity design.

## GUN WATER SYSTEM OVERVIEW

Figure 2 shows a simplified EDM operator display. The process heater is a commercial unit which has its own internal control loop this is set to produce a temperature above the desired temperature, the control valve VP01 then mixes this with chilled water to produces a temperature a few degrees above the control point. Manual valves are set to mix chilled and heated water to a temperature just below the control point. The final stage is where VP02 mixes the two water temperatures close to the set point.

The gun flow and return are via a 12 way manifold with pressure flow and temperature measurements. The manifold also has remote controlled valves feeding the 12 water circuits within the gun. There are 21 temperature measurements in the system 17 having 0.1°C resolution and 4 have 0.001°C resolution. To prevent operation when the water flow or temperature is out of specification the system provides a hard wired interlock to the RF Modulator.

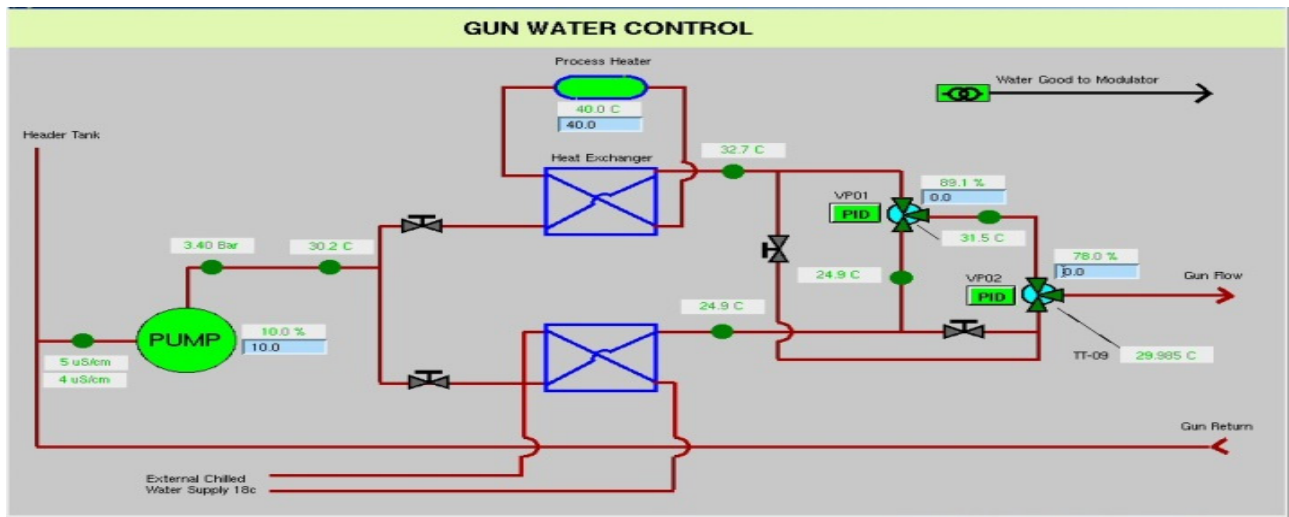

Figure 2: Simplified EDM Overview of the Gun Water System.

## TEMPERATURE ACQUISITION

To control temperature to high resolution requires feedback to a still higher resolution therefore it was decided to evaluate temperature read back devices. Two temperature devices were selected for evaluation (figure 3).

- Gantner Q.bloxx A105 a high precision four channel Pt100 measurement ADC. This used in conjunction with the Q.gate IP provides Ethernet communication.
- Omron PH41U CJ series high precision four channel ADC PLC module.

To Communicate with EPICS the Q.gate IP can be used to allow Ethernet communication to the Q.bloxx A105. A Stream Device protocol was then written to complete the process.

To communicate with the PH41U requires a CJ2M PLC processor which then communicates with an EPICS IOC using the Omron FINS protocol.



Figure 3: Omron and Gantner ADC's.

## ADC EVALUATION

Both devices use similar 24 bit Sigma Delta converters the Gantner unit uses a Burr Brown ADS1552 [3] and the Omron unit uses Analogue Devices AD7794[4] , They also both use one converter per channel.

Each device has four channels. For evaluation they were both configured as follows:

- CH1 – Pt100 sensors for both devices next to each other inside thermal insulation.
- CH2 – In air ambient temperature.
- CH3 - Precision Resistors simulating a Pt100 at 27°C.
- CH4 - Precision Resistors simulating a Pt100 at 96°C.

The EPICS Channel Archiver then recorded the readings from both devices for 6 weeks.

The results from CH1 showed very little difference between the devices both could produce a resolution of 0.001°C and tracked each other throughout the test.

Data from CH2 could be used to track the ambient temperature changes which correlated with CH3 and CH4, both displaying a small drift due to changing ambient temperatures, but again both devices produced the same results indicating that the drift was largely due to the precision resistors (figure 4). Should this test be repeated then the precision resistors could be placed in a temperature stabilised environment.

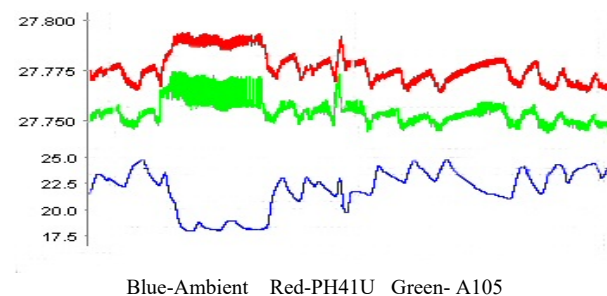

Blue-Ambient Red-PH41U Green- A105

Figure 4: Temperature stability vs ambient over 3 days.

Content from this work may be used under the terms of the CC BY 3.0 licence (© 2017). Any distribution of this work must maintain attribution to the author(s), title of the work, publisher, and DOI.

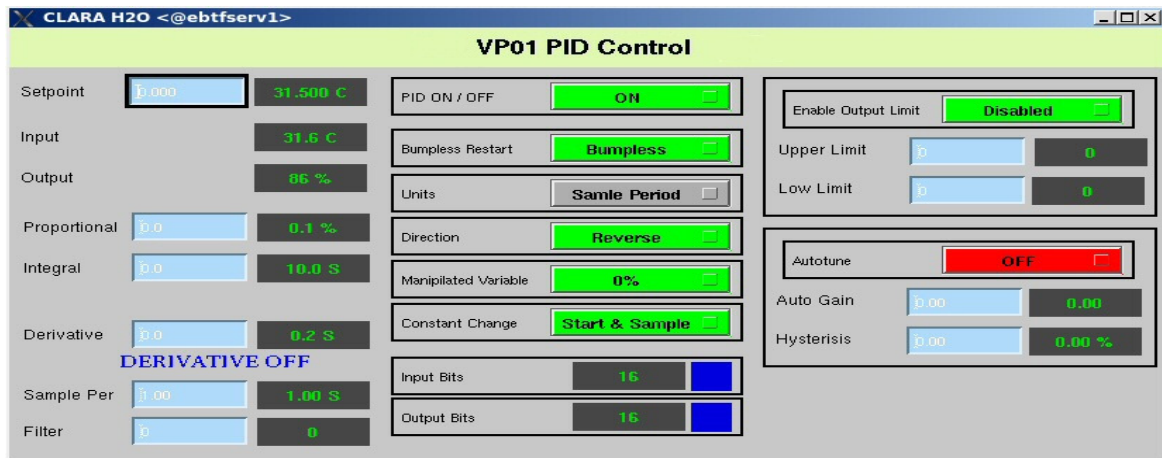

Figure 5: EPICS EDM PID Display.

## HARDWARE SELECTION

The Omron CJ2 PLC is the preferred system for low level plant interface. A distinct reliability advantage can be gained if the temperature read back can be fed directly into the PLC. Due to the evaluation results being so close it allowed a decision to be made based on compatibility with existing systems, therefore it was decided to use the Omron ADC unit. If the control loops are also executed via the same PLC then the temperature control system becomes a standalone system immune to network disturbances and IOC reboots.

## PID

There are two function blocks available one with auto tune and one without. The extra feature to auto tune does not have any disadvantage therefore this option was selected.

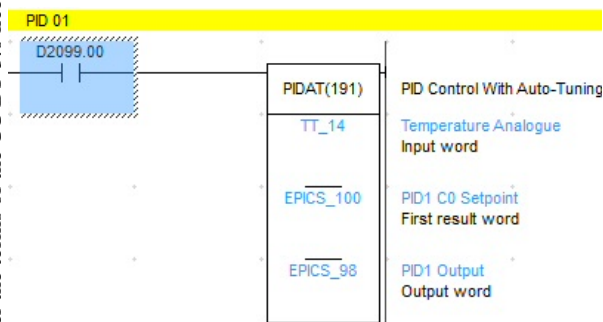

Figure 6: PIDAT Function Block.

The function block appears to only have three parameters (Figure 6) but memory space has to be reserved for setting all the other parameters and also for working memory internal to the routine.

All the control addresses are then mapped back to EPICS read and writes. Figure 5 shows the functionality that can be achieved using this function block.

The PID operates with a resolution of 16 bits, but the temperature read back is 24 bits. The read back is scaled to produce a range of 0 to 100°C in the 16 bit range.

The 16 bit output from the PIDAT is scaled down to 12bits for a 12bit DAC module producing 4-20mA to operate the mixing valves. The water temperatures to be mixed are close allowing 12bits to provide control down to 0.001°C.

## CONCLUSION

There has generally been a limitation to the use of PLC's for high resolution data acquisition and control because of the lack of suitable of high resolution modules especially in mid-range PLC's. This is no longer the case; PLC's can be used to provide precision measurement and control.

We have used CJ2 PLCs for several years with an excellent reliability record. Initially they were used for digital control and interlocking but the potential to provide a complete control solution is now being utilised. Communication via the EPICS FINS interface is also very robust. The CLARA gun is awaiting commissioned but this control method is also being used for the CLARA Linac temperature control which has been successfully RF conditioned while under temperature control.

## REFERENCES

- [1] J. A. Clarke et al., JINST 9, 05 (2014).
- [2] T. Asaka et al., Stability Performance of the Injector for SACLA/XFEL at SPring-8, in proc. of LINAC12, Tel-Aviv, Israel, 2012.
- [3] <http://www.ti.com/lit/ds/symlink/ads1252.pdf>
- [4] [http://www.analog.com/media/en/technical-documentation/data-sheets/AD7794\\_7795.pdf](http://www.analog.com/media/en/technical-documentation/data-sheets/AD7794_7795.pdf)