

EPICS ALSO FOR SMALL AND MEDIUM SIZED EXPERIMENTS*

H. Junkes[†], Fritz-Haber-Institut der Max-Planck-Gesellschaft (FHI), Berlin, Germany

Abstract

The Experimental Physics and Industrial Control System (EPICS) consists of a series of software tools and applications for the development, implementation and operation of distributed control systems. It is used worldwide in many, mostly larger facilities such as particle accelerators, free electron lasers and telescopes. EPICS scales from very large to very small systems due to the efficient memory usage and support of many hardware platforms. This article describes some of these small systems as well as typical experiment controls in chemistry and physics at research institutions. These are placed in the context of large plant controls.

BASIS: SOMEWHAT LARGER EXPERIMENT

A mid-infrared FEL has been commissioned in 2013 at the Fritz-Haber-Institut (FHI) in Berlin. It is used for spectroscopic investigations of molecules, clusters, nanoparticles and surfaces. The oscillator FEL is operated with 15 – 50 MeV electrons from a normal-conducting Sband linac equipped with a gridded thermionic gun and a chicane for controlled bunch compression. Construction of the facility building with the accelerator vault began in April 2010. First lasing was observed on February 15th, 2012 [1]. The EPICS software framework [2] was chosen to build the control system for this facility. The facility management system is integrated using BACnet/IP. Graphical operator and user interfaces are based on the Control System Studio package. The EPICS archiverAppliance, an electronic log-book, a web based monitoring tool, and a gateway complete the installation.

The Max-Planck-Gesellschaft (MPG) has now funded a significant upgrade to the FHI FEL. A second, short-Rayleigh-range undulator FEL beamline is being added that will permit lasing from $<5 \mu\text{m}$ to $>160 \mu\text{m}$. Additionally, a 500 MHz kicker cavity will permit simultaneous two-colour operation of the FEL from both FEL beamlines over an optical range of 5 to $50 \mu\text{m}$ by deflecting alternate 1 GHz pulses into each of the two undulators [3].

ADDON: STANDARD/SMALL EXPERIMENTS

Based on the EPICS infrastructure, which is available at the institute through the FEL project, this environment has been used for experiment control in many standard experiments at the institute since then. Some special solutions could also be implemented cheaply and efficiently.

Small but Fine Devices

Due to the small footprint of EPICS and the support of the ARM processor family it is possible to realize an Input/Output Controller (IOC) on the Raspberri Pi Single Board Computer (SBC).

Measurement@20 kV The IOC runs on a Raspberry Pi Zero W. It has all the functionality of the original Pi Zero, but comes with added connectivity, consisting of [4]:

- 802.11 b/g/n wireless LAN
- Bluetooth 4.1
- Bluetooth Low Energy (BLE)

A mounting device was built to allow the Pi Zero be attached on top of the Fluke 287 (True RMS Multimeter). For the communication with the Fluke, the infrared connector of the multimeter is used. The conversion into a serial signal (RS232) is done on the holding device. The battery of the multimeter is used to power the Pi Zero. This allows the instrument to be operated (incl. EPICS IOC) at 20 kV. This is used, for example, to detect voltage breakthroughs in cold molecule traps.



Figure 1: Holding plate with Pi Zero.

* Work supported by Max-Planck-Gesellschaft, Germany
[†] junkes@fhi-berlin.mpg.de

Any distribution of this work must maintain attribution to the author(s), title of the work, publisher, and DOI.

The user interface is realized with Phoebus (successor of Control System Studio (CSS)) [5]. The measurement data (process variables (PVs)) are automatically recorded by the existing EPICS archiverAppliance [6] and are available for later evaluation.



Figure 2: Phoebus OPI.

As with the typical EPICS installation, software development and configuration are supported by versioning tools. In our case, for historical reasons, this is mercurial (hg). The save and restore functionality is given by the EPICS module *autosave*.

Devices@facility The suppliers of building automation technology tend to sell their products at very high prices. They try to maneuver customers into a vendor lock. In order to minimize these dependencies, we at the institute have been trying for some time to build our own products with open software and hardware. Our latest project is to replace a commercial access control system with our own developed system. We use a Raspberry Pi 3 on which we install an EPICS IOC.

This project is carried out with trainees at the institute. Trainees from different disciplines (mechanical workshop, electronics lab, network centre, core-IT, building services) work together to develop equipment for the entire FHI campus. Commissioning is scheduled for mid-2020. A *mifare* card reader (NFC) is used which is connected to the Raspberry Pi as a serial device. The digital I/O of the Raspberry Pi controls the door opening mechanism and monitors reed relays which indicate the door status (open, closed). The EPICS IOC uses *asyn* device support for the communication with the card reader. The management of the system is realized with a web interface on a Unix server system.

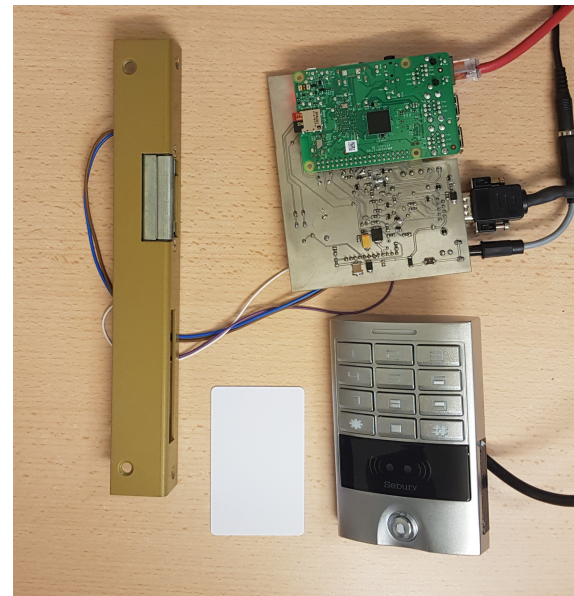

Figure 3: Door controller.

Logging is done via *rsyslog* into a *mongo* database. The administrative data and the audit log are stored in a *mysql* database. The status information is monitored by the EPICS *alarmhandler* (alh). The IOC with its records is integrated in the automation control system via a BACnet gateway [7].

Devices@industry In order to be able to use devices in certain areas (control in safety areas such as emergency power supply, elevator systems, personal protection, etc.), they must comply with the *industrial standard* EN 61131-2. Here we use the Raspberry Pi system in a DIN rail housing [8]. These systems are supplied with 24V, typical for industrial PCs.

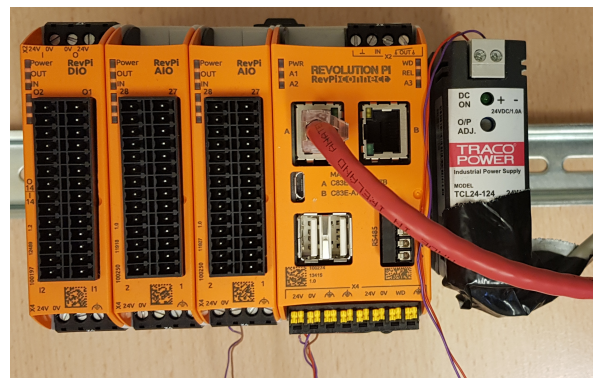

Figure 4: KUNBUS Revolution Pi.

There are industrial I/O modules and fieldbus gateways for this IPC. The IOC on these devices has *asyn* support and supports protocols like *modbus*, *BACnet*, *PROFINET*, *Sercos 3*, *EtherCAT*, *DeviceNet*,...

Equipment in “Normal” Research Facilities

An EPICS IOC can be used on all common systems (Unix, Windows, OS-X). This makes it possible to install a so-called *softIOC* on already existing computers which then takes over the communication with the existing devices. Such a system can then be integrated into the EPICS environment of the institute via a *ca-gateway* [9].

Default@chemistry Most experiments in chemistry at institutes of basic research do not have a high degree of automation. Usually, several proprietary (hardware and software) devices are operated side by side without direct synchronization. Usually the start of measurements and the operation during the measurement is done manually. Often laboratory books (classic on paper) are also used. There is usually no machine protection (e.g. vacuum control, etc.). There is usually no machine protection (e.g. vacuum control, etc.).

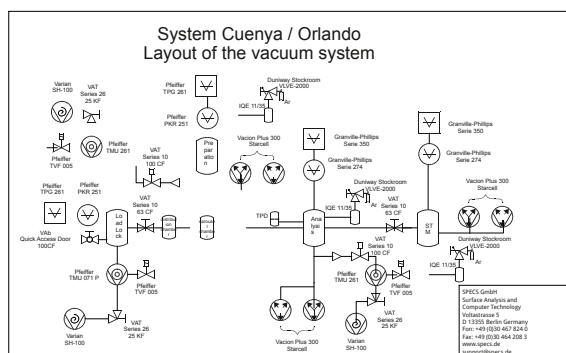

Figure 5: Vacuum scheme for a typical chemical experiment

The operations performed are rarely time-critical. Typical actions are:

- Temperature read out
- Pressure read out
- Temperature control (e.g. oven)
- Switching valves
- Control / read out devices (Gas chromatography (GC), Residual Gas Analyzer (RGA), ...)
- Camera read out

These experiments are relatively easy to upgrade for automation using EPICS IOCs. The devices to be controlled can usually be read out via serial interface (RS232, RS485) or network. Among other things, terminal servers can be used to bundle the serial connections on the network. On the IOC the device control can be realized with *asyn/IP* support and *streamdevice*. The EPICS *scanServer* [10] can be used to fully automate experiments and ensure reproducibility and quality assurance. The use of electronic laboratory books is thus also simplified and can be integrated into the process flow.

A major problem in this environment are the manufacturers of analytical instruments. They are often not willing to disclose the protocols for controlling their devices. In order to do justice to good scientific practice and to be able to understand at any time how data is generated and recorded, only devices with at least the protocol structure for communication documented should be used.

Default@physics Experiments in physics usually look a little different from experiments in chemistry. These have usually achieved a high degree of automation and are characterized by the following requirements:

- Fast data acquisition
- Tight synchronisation
- High data rate
- Event driven
- High density I/O
- Fast interlock / machine protection

In order e.g. to directly resolve dynamic processes of atom diffusion, film growth and chemical reaction, a lot of effort has been made at the institute to construct a Scanning Tunneling Microscope (STM) that can scan following such processes at time scales ranging from a few seconds down to milliseconds. A challenge on such an apparatus is the high speed electronics for hardware controlling and data acquisition. A data acquisition system based on VMEbus with *Real-Time Executive for Multiprocessor Systems* (RTEMS) as operating system was realized to scan with about 4500 frames/s. This end up with a data rate of about 4.1 Gbit/s.

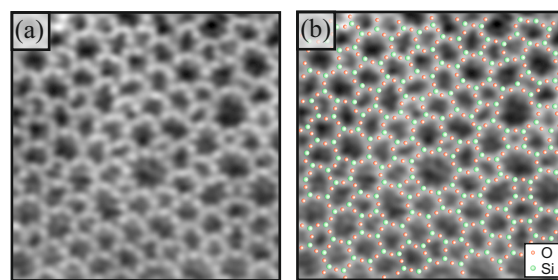

Figure 6: Atomically resolved SPM images of the vitreous silica film. a) shows the atomically resolved contrast. b) overlaid with marked positions of the topmost Si (green balls) and O (red balls) atoms. Reproduced with the permission of [11].

RTEMS is a multi-threaded, single address-space, real-time operating system with no kernel-space/user-space separation. It is capable to operate in an SMP configuration providing a state of the art feature set [12]. EPICS 7 had already been adapted for the new RTEMS5 [13]. The adaptation is still in beta status. It completely uses the Posix-API. As soon as RTEMS 5.1 is released, it will be officially supported by EPICS. Currently we are working on the support for new hardware (QorIQ, Multicore P2020) and the integration of *libbsd* into EPICS/RTEMS. This should be available at the beginning of 2020.

CONCLUSION

It has been shown that EPICS can also be used sensibly on inexpensive hardware to build distributed systems. One problem is the steep learning curve to be able to use EPICS. In order to provide better support for beginners, the MPG has initiated a project to actively contribute to the documentation, training courses and support during the initial installation of EPICS. Above all, the use of e.g. the archiverAppliance and electronic laboratory books (elog) is the focus of efforts here. In such a well-defined and transparent measurement environment, the FAIR principles (Findable, Accessible, Interoperable, Reusable) as demanded by many research organizations today are fulfilled [14]. The consistent use of electronic labbooks further supports these FAIR principles.

ACKNOWLEDGEMENTS

These developments are only possible with the tireless support of the EPICS community. Special thanks to

A. N. Johnson, G. Shen, and S. Veseli, Argonne National Laboratory, Lemont, Illinois, USA

K. Shroff, Brookhaven National Laboratory, Upton, New York, USA

T. Korhonen, European Spallation Source ERIC, Lund, Sweden

M. G. Konrad, FRIB, East Lansing, Michigan, USA

R. Lange, ITER, St. Paul lez Durance, France

S. M. Hartman and K. U. Kasemir, Oak Ridge National Laboratory, Oak Ridge, Tennessee, USA

M. A. Davidsaver, Osprey DCS LLC, Ocean City, Maryland, USA

M. R. Kraimer, Osseo, Michigan, USA

K. Kim, SLAC National Laboratory, Menlo Park, California, USA

REFERENCES

- [1] W. Schöllkopf *et al.*, “First Lasing of the IR FEL at the Fritz-Haber-Institut Berlin”, in *Proc. 34th Int. Free Electron Laser Conf. (FEL'12)*, Nara, Japan, Aug. 2012, paper MOOB01, pp. XX–XX.
- [2] EPICS, <https://epics-controls.org>
- [3] A. M. M. Todd *et al.*, “The FHI FEL Upgrade Design”, in *Proc. 10th Int. Particle Accelerator Conf. (IPAC'19)*,

Melbourne, Australia, May 2019, pp. 1903–1905. doi:10.18429/JACoW-IPAC2019-TUPRB103

- [4] <https://www.raspberrypi.org/products/raspberry-pi-zero-w>
- [5] Phoebus Documentation, <https://buildmedia.readthedocs.org/media/pdf/phoebus-doc/latest/phoebus-doc.pdf>
- [6] D. Rogind *et al.*, “Roadmap for SLAC Epics-Based Software Toolkit for the LCLS-II/III Complex”, in *Proc. 16th Int. Conf. on Accelerator and Large Experimental Control Systems (ICALEPCS'17)*, Barcelona, Spain, Oct. 2017, pp. 1389–1392. doi:10.18429/JACoW-ICALEPCS2017-THPHA022
- [7] S. B. Webb, “Using BACnet to Integrate Conventional Facilities Into EPICS at SNS”, presented at the 17th Int. Conf. on Accelerator and Large Experimental Control Systems (ICALEPCS'19), New York, NY, USA, Oct. 2019, paper WEPHA159.
- [8] KUNBUS Open Source IPC, <https://revolution.kunbus.com>
- [9] EPICS-Extension, ca-gateway, <https://github.com/epics-extensions/ca-gateway>
- [10] K.-U. Kasemir and M. R. Pearson, “CS-Studio Scan System Parallelization”, in *Proc. 15th Int. Conf. on Accelerator and Large Experimental Control Systems (ICALEPCS'15)*, Melbourne, Australia, Oct. 2015, pp. 517–520. doi:10.18429/JACoW-ICALEPCS2015-TUA3004
- [11] Heyde, Markus and Simon, Georg H and Lichtenstein, Leonid, “Resolving oxide surfaces—from point and line defects to complex network structures”, in *physica status solidi(b)*, 2013, Vol. 250, Nr. 5, pp. 895–921.
- [12] RTEMS 5, <https://devel.rtems.org/wiki/Release/5/5.1>
- [13] H. Junkes, H.-J. Freund, L. Gura, M. Heyde, P. Marschalik, and Z. Yang, “Experiment Control with EPICS7 and Symmetric Multiprocessing on RTEMS”, in *Proc. 16th Int. Conf. on Accelerator and Large Experimental Control Systems (ICALEPCS'17)*, Barcelona, Spain, Oct. 2017, pp. 1762–1766. doi:10.18429/JACoW-ICALEPCS2017-THPHA154
- [14] FAIRDI, <https://fairdi.eu/>