

# DEVELOPMENT OF A VOLTAGE INTERLOCK SYSTEM FOR NORMAL-CONDUCTING MAGNETS IN THE NEUTRINO EXPERIMENTAL FACILITY AT J-PARC

K. Nakayoshi\*, K. Sakashita, Y. Fujii

High Energy Accelerator Research Organization (KEK), Tsukuba, Japan

## Abstract

We are upgrading the neutrino experimental facility beamline at J-PARC to realize its 1.3 MW operation. One of the upgrade items is to strengthen the machine protection interlocks at the beamline. So far, we have developed an interlock system that monitors the output current of the power supplies for the normal-conducting magnets in the primary beamline. On the other hand, a coil-short in one of the bending magnets at a beam transport line (3-50BT) at J-PARC happened in 2019, and it caused a drift of the beam orbit over time. Our present interlock system cannot detect a similar coil-short in the magnet, while such a change of the beam orbit may cause serious damages. One possible way to detect such a coil-short is to monitor the voltage of the magnet coil. Actually, a significant voltage drop between layers of the coil was observed for the 3-50BT magnet coil-short. Focusing on that fact, we are developing a system that continuously monitors the voltage value of the magnets at the primary beamline and issues an interlock when there is a fluctuation exceeding a threshold value. We report on the progress of the development of this system.

## BACKGROUND

At the neutrino experimental facility at J-PARC, a large amount of neutrinos are generated using a high-intensity proton beam extracted from the Main Ring Synchrotron (MR) and sent towards the Super-Kamiokande detector, 295 km away, for a long baseline neutrino oscillation experiment (the T2K experiment) [1]. The MR stopped operation in July 2021 and upgrades, such as replacing the power supplies are ongoing. The beam to the T2K experiment is scheduled to resume in the fall of 2022. Also, the neutrino beamline equipment is being upgraded to support a beam intensity enhancement [2]. Figure 1 shows the primary proton beamline of the neutrino experimental facility. The proton beam extracted from the MR is transported to the graphite target 240 m away by 14 doublet super-conducting magnets (hatched in yellow) and 21 normal-conducting (NC) magnets (hatched in blue). If an abnormality occurs in the transport system of the primary proton beamline during beam operation, the high-intensity proton beam may deviate from the normal orbit and hit the beamline equipment. In that case, the thermal shock of the high-intensity proton beam could cause serious damages to the beamline equipment, which would take a long time to recover. In order to avoid such a situation, we have strengthened the interlock so far. For NC

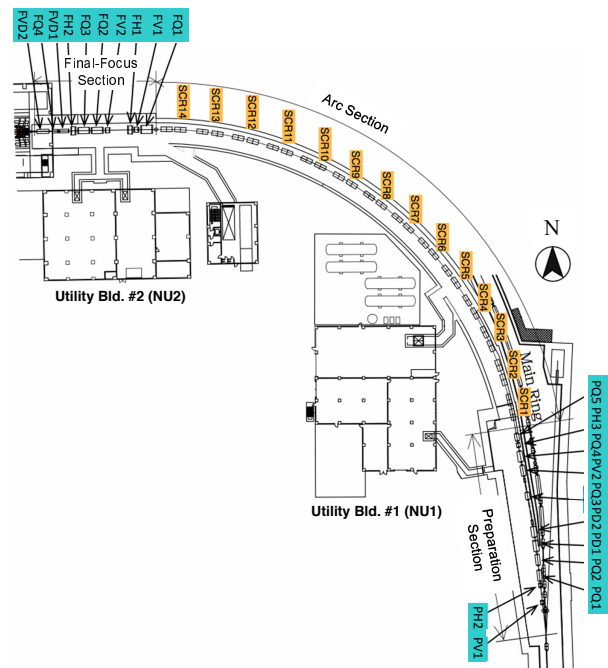

Figure 1: The primary proton beamline of the neutrino experimental facility at J-PARC.

magnets, we have developed an interlock system for detecting current fluctuations in the NC power supplies and have been operating this system from 2012 to the present [3, 4]. When an interlayer short circuit occurred in a dipole magnet coil of J-PARC's beam transport line in 2019, there was no change in the current Value of the power supply, but fluctuations in the voltage of the corresponding magnet coil were observed [5]. This means that our current fluctuation interlock cannot detect an interlayer short circuit of the NC magnets. In order to further strengthen the interlock of the NC magnet system, we are developing a system that detects a voltage fluctuation of the NC magnets and issues an interlock. The target value of the voltage fluctuation detection system was set to 1%.

## PRELIMINARY STUDY

### How Can We Measure the Magnet Coil Voltage?

Before developing the voltage interlock system, we made a preliminary measurement of the magnet coil voltage. During the accelerator operation, the voltage of the magnet coil

\* kazu.nakayoshi@kek.jp

was measured to check its noise level, and whether an interlock that detects voltage fluctuations and issues an interlock is feasible. The measurement was performed for 5 hours using a digital multimeter Keithley 2701. Figure 2 shows a histogram of the results of the measurement. The average value of the histogram in Fig. 2 is 49.5 V and the full width is 0.120 V (*full width/average* = 0.24%). It was found that the voltage of the magnet coil could be measured at the power supply on the ground floor with the required accuracy even when the accelerator was in operation.

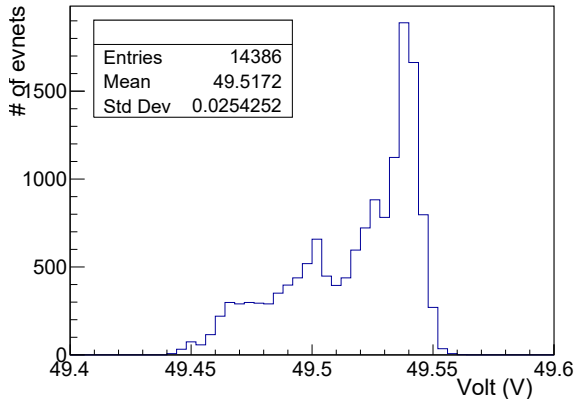

Figure 2: The result of a preliminary measurement of the magnet coil voltage.

### What Kind of System We Will Adopt?

Figure 3 shows the equivalent circuit of our voltage fluctuation detection circuit. In order to minimize the magnet current deviation, we considered a voltage divider circuit. The NC magnet impedance is 39.3 mΩ. Taking the power consumption of the voltage fluctuation detection circuit into account, we decided to set the impedance  $R_s$  of the voltage divider circuit + ADC to  $10\text{ k}\Omega \leq R_s \leq 10\text{ M}\Omega$ .

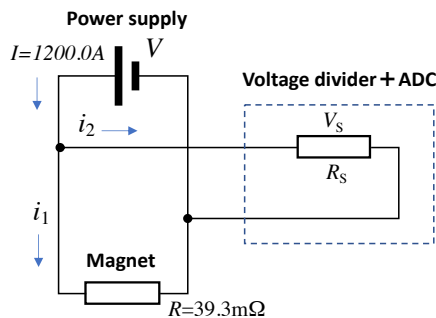

Figure 3: Equivalent circuit when the voltage divider circuit and ADC are connected to the magnet and power supply.

In order to realize a small latency and an intelligence function, we are evaluating a system using an Arduino UNO [6] left side of Fig. 4 and external ADC. For this study, we evaluated a Pmod-type ADC board [7] equipped with AD7685 (16 bit, 250 kSPS), right side of Fig. 4. The input impedance

of this board is as small as 0.4 kΩ, and since it does not meet the impedance required by this system, the resistance of the board was changed to 10 kΩ. An external resistor of 190 kΩ was attached in front of the ADC to divide the voltage at 20:1.

We will use EPICS as a control framework for the voltage interlock system like other interlocks in the neutrino facility. Also, a Raspberry Pi 3 [8] is used as an interface between the EPICS IOC and Arduino.

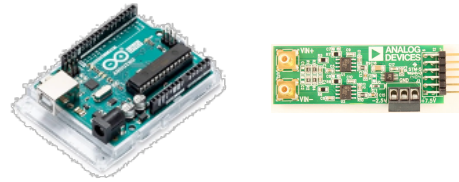

Figure 4: Arduino UNO (left) and Pmod type ADC (right).

## VALIDATION OF THE USE OF ARDUINO AND ADC

### Check Feasibility of ADC Readout by Arduino With SPI

Since the Pmod ADC board supports SPI (Serial Peripheral Interface, an interface bus commonly used to send data between microcontrollers and peripherals), we implemented SPI transfer with the Arduino. Figure 5 shows the wiring of the Arduino and Pmod ADC for SPI transfer. It was confirmed that the data can be read by SPI communication using a 3-wire mode with no busy indicator.

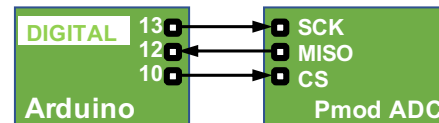

Figure 5: Wiring for SPI between the Arduino and Pmod ADC.

To check if the Arduino could read the ADC sampling data correctly, we read a sine wave output from a function generator using the Arduino. Figure 6 shows a graph of a 3 Hz, 1 V<sub>pp</sub> input signal obtained by the Arduino.

We also measured the linearity of the Pmod ADC. The input to the Pmod ADC is the output of the DC power supply. Figure 7 shows the results.

### Check the Functions Required for the Interlock System

We checked the Arduino for the following features needed for the interlock function.

- Checking the ability to compare read data with thresholds
- Implementation of threshold setting using interrupts
- Confirmation that the signal can be output as an interlock

Content from this work may be used under the terms of the CC BY 3.0 licence (© 2022). Any distribution of this work must maintain attribution to the author(s), title of the work, publisher, and DOI

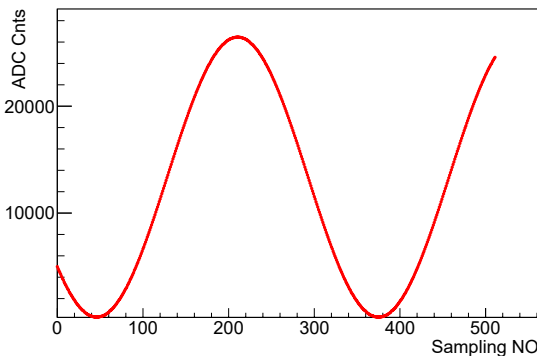

Figure 6: Sine waveform acquired by the Arduino and Pmod ADC.

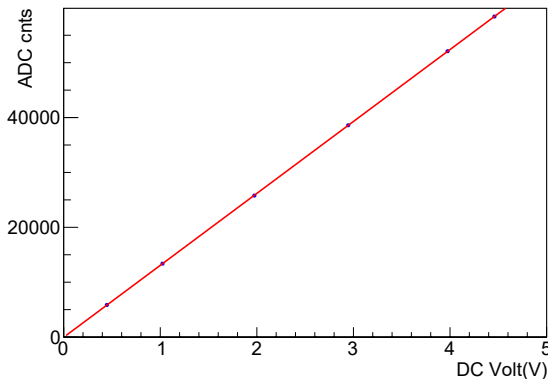

Figure 7: Results of linearity check for Pmod ADC.

The prototype provided the three operating modes shown in Fig. 8. In the normal mode, the Arduino reads the ADC

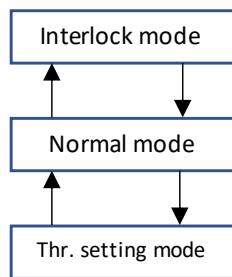

Figure 8: Operation modes for the Arduino.

value at 1 kHz, compares it with the threshold value, and transfers the ADC and threshold value to the Raspberry Pi at 1 Hz. When the ADC value exceeds the threshold value, the mode transitions to the interlock mode. The Arduino sets the digital output pin to HIGH and issues an interlock. In the threshold setting mode, the threshold value can be changed by sending a new threshold value from the Raspberry Pi to the Arduino. Changing the operation mode between the normal mode and the threshold setting mode is done utilizing the interrupt function of the Arduino.

### Threshold Setting Using Interrupts

Arduino interrupts were used to set the threshold for detecting voltage fluctuations. By turning on the interrupt signal for the Arduino from the GPIO pin of Raspberry Pi, an

interrupt for the Arduino is generated. The function called at the time of interrupt reads the threshold value written before the interrupt from the buffer and updates the threshold.

## PROTOTYPE DEVELOPMENT

### Prototype Configuration

Figure 9 shows the configuration of the prototype. The Pmod ADC board and Arduino are connected via a conversion board. The Arduino is connected to a relay board to output the interlock signal. The Arduino and the Raspberry Pi are connected with a USB cable and serial transfer is possible. Also, a cable is connected between the Raspberry Pi and Arduino for an interrupt signal. The Raspberry Pi communicates with the EPICS IOC via a media converter.

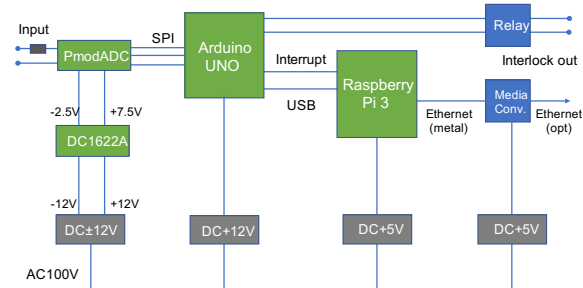

Figure 9: Diagram of the prototype.

### The Prototype in a Box

The prototype has been made into a single box for future performance evaluation tests (Fig. 10). The relay module and media converter for Ethernet keep this box electrically isolated from downstream systems. The size of the box is 430 mm × 330 mm × 115 mm.

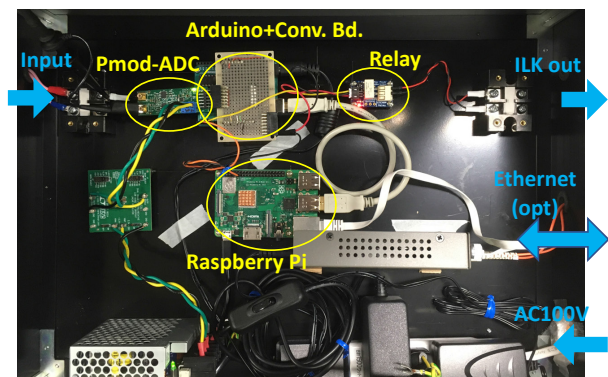

Figure 10: The prototype in a box.

## PERFORMANCE EVALUATION

### Long-Term Stability Test

To evaluate the performance of the prototype, a stability test was conducted for 8 hours. As an input signal, a constant DC voltage of 10 V was injected using a DC power

supply. The results are shown in Fig. 11. We found some noise spikes, but they were smaller than our target of <1% variation (red dashed line in the figure). We are now trying to determine the cause of these noise spikes and how to reduce them.

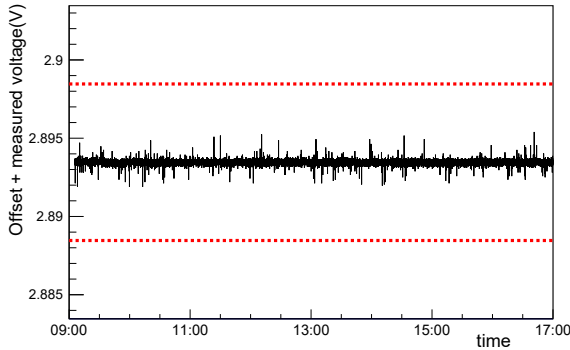

Figure 11: The result of the long-term stability test.

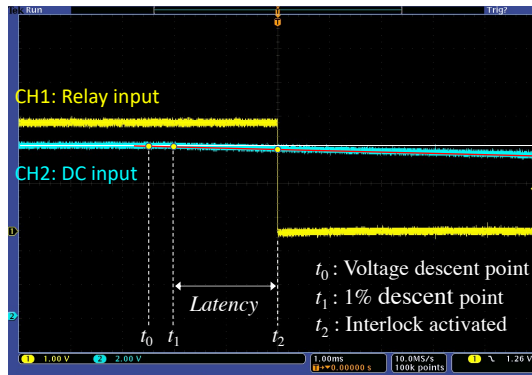

Figure 12: The result of the interlock latency measurement.

### Interlock Latency Measurement

To measure the latency of the interlock, we used a DC power supply with an output of 10 V. The threshold value was set to  $\pm 1\%$  of the average value, and the output voltage was changed to trigger the interlock by hand. The latency time was measured by an oscilloscope (Fig. 12). In Fig. 12, CH2 (blue line) is an input to the ADC from the DC power

supply, and CH1 (yellow line) is an output of the Arduino to the relay.  $t_0$  is the time when the voltage starts to decrease.  $t_1$  is the time when the voltage has decreased by 1%.  $t_2$  is the time the interlock was activated. We fit the CH2 data with two linear functions and set their intersection point as  $t_0$ . The latency time was calculated as  $t_2 - t_1$ . Ten measurements were taken, and the average latency time was 2.1 ms.

## SUMMARY AND FUTURE PLANS

In order to strengthen the interlock of the primary proton beamline NC magnets of the J-PARC neutrino experimental facility, we are developing a system that continuously monitors the voltage of the magnet coils and issues an interlock when the threshold is exceeded. We developed a prototype of the system. For the next step, the prototype will be attached to the NC power supply for testing and improvement. After that, the actual system will be fabricated, and when the experiment resumes in the fall of 2022, the beamline will be operated with this interlock installed.

## REFERENCES

- [1] K. Abe *et al.*, “The T2K experiment”, *Nucl. Instrum. Methods Phys. Res., Sect. A*, vol. 659, no. 1, pp. 106-135, Dec. 2011. doi:10.1016/j.nima.2011.06.067
- [2] K. Abe *et al.*, “J-PARC Neutrino Beamline Upgrade Technical Design Report”, 2019. arXiv:1908.05141
- [3] K. Nakayoshi, Y. Fujii, and K. Sakashita, “Improvements in the T2K Primary Beamline Control System”, in *Proc. ICALEPCS’13*, San Francisco, CA, USA, 2013, paper TUCOCA10, pp. 940-943. <https://jacow.org/ICALEPCS2013/papers/tucoca10.pdf>
- [4] K. Nakayoshi, Y. Fujii, and K. Sakashita, “Upgrade of the Control and Interlock Systems for the Magnet Power Supplies in T2K Primary Beamline”, in *Proc. ICALEPCS2015*, Melbourne, Australia, Oct. 2015, pp. 160–162. doi:10.18429/JACoW-ICALEPCS2015-MOPGF030
- [5] J. Takano, “Layer Short Circuits of Bending Magnets in the J-PARC Main Ring and 3-50BT”, in *Proc. J-PARC2019*, vol. 33, p. 011037, 2021. doi:10.7566/JPSCP.33.011037
- [6] Arduino website: <https://www.arduino.cc/>
- [7] Analog Devices, PulSAR ADC PMODs: <https://wiki.analog.com/resources/eval/user-guides/circuits-from-the-lab/pulsar-adc-pmods>
- [8] Raspberry Pi Foundation website: <https://www.raspberrypi.org/>