

# LHC INJECTION PROTECTION DEVICES, THERMO-MECHANICAL STUDIES THROUGH THE DESIGN PHASE

I. Lamas Garcia<sup>†</sup>, N. Biancacci, G. Bregliozzi, M. Calviani, M.I. Frankl, L. Gentini, S. Gilardoni, A. Lechner, A. Perillo-Marcone, B. Salvant, N.V. Shetty, J. Uythoven, CERN, Geneva, Switzerland

## Abstract

The TDI (Target Dump Injection) is a beam intercepting device installed on the two injection lines of the LHC. Its function is to protect the superconducting machine elements during injection in the case of a malfunction of the injection kickers.

The TDIS (Target Dump Injection Segmented), which will replace the TDI, is foreseen to be installed for high luminosity operation. Due to the higher bunch intensities and smaller beam emittances expected, and following the operational experiences of the TDI, a complete revision of the design of the jaws must be performed, with a main focus on the material selection.

Furthermore, the new TDIS will also improve the TDI reliability by means of a robust design of the jaw positioning mechanism, the efficiency of the cooling circuit and by reducing its impedance. A simplified installation procedure and maintenance will also be an important requirement for the new design.

This paper introduces the main characteristics of the TDI as LHC injection protection device, showing the needs and requirements for its upgrade. It also discusses the thermo-mechanical simulations that are supporting and guiding the design phase and the material selection, and describes the modifications to be implemented, so far, for this new device.

## INTRODUCTION

The injection of the 450 GeV proton beams from the SPS to the LHC machine is made through two transfer lines, TI2 and TI8. The beam to be injected passes through 5 horizontally deflecting septum magnets (MSI) and a vertically deflecting kicker (MKI) consisting of 4 modules.

An uncontrolled beam loss resulting from errors in the MKI pulsing could result in serious damages of the equipment in the LHC injection regions (in particular the superconducting separation dipole D1), the triplet magnets near ALICE or LHCb experiments, or in the arcs of the LHC machine itself.

Therefore, a vertically movable 2-sided absorber TDI is installed at each injection region, about 70 m from the MKI, at a 90° phase advance, in order to protect the LHC equipment from damage in case of kicker failures [1].

Each TDI consists of two 4.2 m absorber jaws. The upper jaw intercepts injected beam which is not (or not sufficiently) deflected by the injection kickers. In the event of a kicker misfiring, the lower jaw will intercept the affected circulating beam.

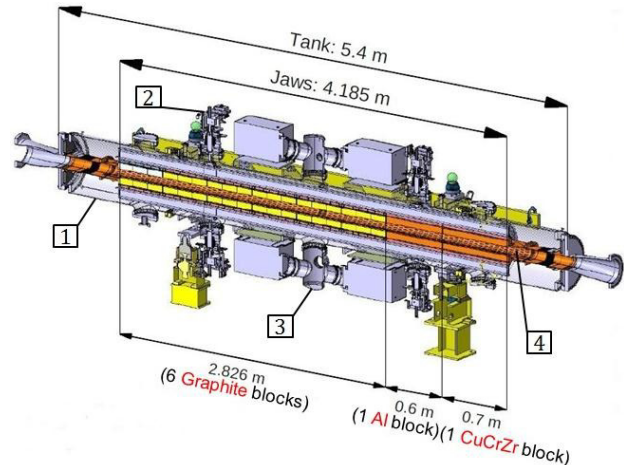

Figure 1: Current TDI configuration.

The currently installed TDI configuration is shown in Figure 1. Its main systems are: (1) Tank, made of stainless steel, operating under UHV conditions. (2) Motorizations, 2 per jaw, driven by stepper motors. (3) Vacuum system, 4 (2+2) ionic pumps operating through a pumping cross which holds inside a NEG cartridge. (4) RF screen, made of stainless steel, which guarantees electrical conductivity.

Each jaw (see Figure 2) is made of: (5) A stainless steel beam connected at 2 fixation points to the shaft of the motorizations. (6) A series of 8 aluminum frames that host the absorber blocks. (7) A cooling circuit made of Cu clamped to the frame. (8) A series of 8 absorbing blocks made out of Graphite R4550, AW5083-H116 and CuCrZr configured as shown on Figure 1.

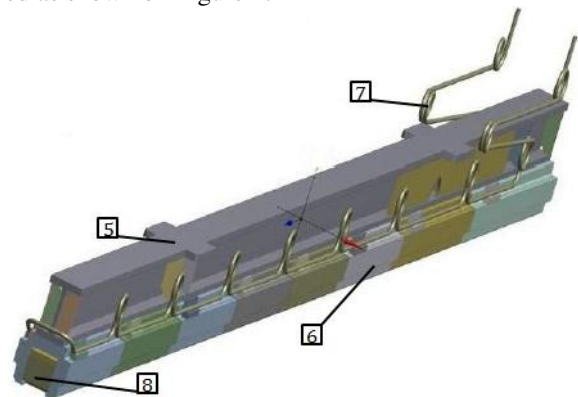

Figure 2: Current TDI jaw configuration.

## NEEDS FOR A NEW TDI – THE TDIS

### *Intrinsic Issues on the Current TDI*

The main issues of the TDI are related mainly to the heat load, which can come from 3 different sources.

<sup>†</sup> inigo.lamas.garcia@cern.ch

The first source is the energy deposited on the absorbing blocks by a direct impact of a fail-injected proton beam (up to now, standard Run 2), with an intensity of  $288 \times 1.2 \cdot 10^{11}$  ppp, a pulse duration of 7.2  $\mu$ s, and a transverse normalised emittance of 2.6  $\mu$ m ( $1\sigma$ ). This scenario produces a highly localised temperature rise of around 600 °C at the first graphite block (around 185mm from upstream). Nevertheless, the absorbing materials have been chosen and dimensioned to cope with the stresses generated by this worst case failure scenario (max tensile/compressive stress on graphite: 8.1 MPa/-24.4 MPa, Stassi Safety Factor above 3.1) [2]. The temperature gradient is so fast and localised that never reaches any contact surface and so the energy is dissipated on the bulk material.

The second source of heat load is the wall resistive impedance due to the beam induced current. It depends on the electrical resistivity of the material, and it generates an estimated power loss of around 100W during injection [3].

The third source of heat load are the trapped High Order Modes. They are distributed from 31 MHz onwards and they heat up different locations in the TDI. They generate an estimated power loss of 10-100 W per mode, for a total of 1 kW [4].

Due to the fact that the second and third source produce a constant heating on the TDI during operation, and that the cooling circuit was not optimised for the first generation TDI, an elastic deformation of the TDI jaw occurred during Run I. This phenomenon could be observed indirectly by the drift shown by the LVDTs readings (elements 1 and 2 in Figure 3) [5]. The deformation is not straight forward to correlate with the drift, and is even more acute due to the feeble fixation system, which is attached only by 2 points, and does not allow a straight longitudinal displacement.

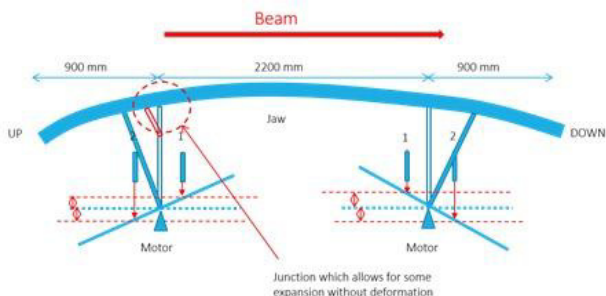

Figure 3: Jaw deformation by beam induced RF heating and representation of the motorization-jaw attachment.

Clearly there is an imperative need for a new TDI design with a main focus on reviewing the systems that could solve or improve the issues explained above. The respective design improvements are:

1. A more efficient cooling circuit, better integrated in the jaw, in order to dissipate the beam induced RF heating.
2. A more robust and reliable motorization system and fixation points to contain and guide any possible deformation.
3. A way of continuously and directly monitoring the distance between the jaws.

4. A new geometry with smaller cavities, better contacts and RF fingers to damp as much as possible the HOM.

### High Luminosity Beam Parameters

Apart from the previously established, the HL-LHC beams will set a record on high intensities and small emittances. See Table 1 for the comparative Run 2 v/s HL beams [6].

Table 1: Run 2 v/s HL-LHC Beams

Beams	Bunch intensity [ppp]	Emittance [ $\mu$ m]
Run 2 Standard	$1.2 \cdot 10^{11}$	2.6
HL-LHC Standard	$2.3 \cdot 10^{11}$	2.1

This means that the TDI material selection must be reviewed due to the higher and more localised temperatures and stresses generated by the impact.

### TDIS THERMO-MECHANICAL SIMULATIONS

Even though it is not a strong constrain, for practical reasons, the goal was to keep the total length of the TDIS the same as the TDI. The first approach is an independent modular design, represented in figure 4, which will simplify the assembly procedure, the installation, the maintenance and the storage.

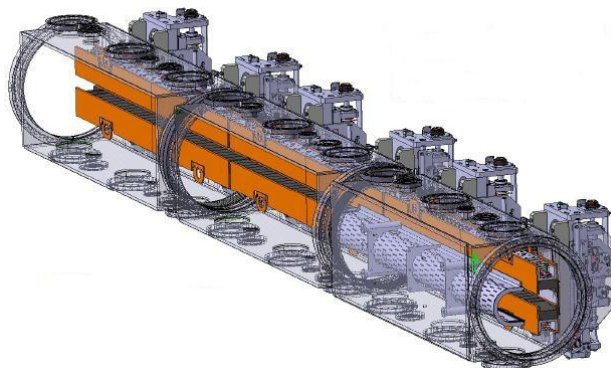

Figure 4: TDIS modular design.

Each of the 3 modules will be of the same length. The 2 upstream ones will accommodate lower-Z absorber materials while the third one will contain higher-Z materials [7].

### Absorbing Material Selection

Several low-Z materials (Graphite, hBN, CFC) have been simulated under a direct impact of a fail-injected HL proton beam, with an intensity of  $288 \times 2.3 \cdot 10^{11}$  ppp, a pulse duration of 7.2  $\mu$ s, and a transverse normalised emittance of 2.1  $\mu$ m. Each of the 2 low-Z blocks presents a dimension of 80 mm x 50 mm x 1700 mm.

To date, the best candidate material is Graphite R4550 – for which CERN has quite a large experience–, which will undergo max. temperature of 1250 °C and a max. tensile/compressive stress of 33 MPa/-80 MPa, Mohr-Coulomb Safety Factor of 0.86 [8]. Further correlations about

the R4550 performance are being assessed by means of experimental tests at the HiRadMat facility [9].

For high-Z material selection, 3 different options have been simulated, each one of them with a different sandwich configuration. According to the simulations (results shown on Table 2), the best option would be a sandwich of a AW6061 block with a length of 900mm followed by a CuCrZr block with a length of 600mm [10].

Table 2: Summary of High-Z Material Results

Option	Material	Max T [°C]	Max Ppal. Stress [MPa]	Min Ppal. Stress [MPa]
1	AW6061	184	115	109
	Ti6Al4V	264	200	194
	CuCrZr	72	98	95
2	AW6061	184	115	109
	Ti6Al4V	119	80	79
	WNiCu	182	249	239
3	AW6061	184	115	109
	CuCrZr	125	200	194

### Jaw Design Considerations

Several jaw configurations have been analysed. The process has been iterative and the main variables to define have been the materials to be used, the dimensions of the constituent elements and the methods to assure contact between them.

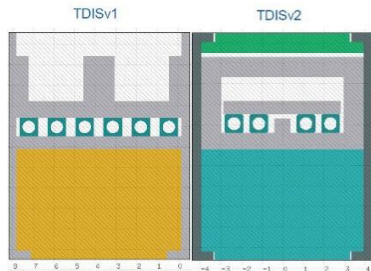

Figures 5 and 6: Cross-section view of 2 versions of the jaw configuration.

Simulations have been performed to assess the behaviour of the jaw under secondary proton showers produced by a direct impact on the absorbing block [11].

A new active cooling circuit has also been simulated under the assumption of 2 kW of power losses expected during operation, in order to assess its efficiency and to determine the method needed to assure a proper thermal contact [12].

Following the previous studies, an AW6061-T6 frame has been selected (configuration as Fig. 6, TDisv2), in which a max. T of 122 °C and a max von Mises stress of 180 MPa are reached. The frame creates a more rigid structure for the whole jaw and protects the cooling circuit made of CuNi pipes, which are clamped to it by springs, and that dissipates with great efficiency the heat load. In steady state conditions, the max. temperature reached at injection is of 45 °C, while during operation it is of 30 °C [12].

### General Design Considerations

In order to make a more robust jaw positioning mechanism, each module will have its correspondent independent system conformed by 2 mechanical tables with 2 stepper motors each (Fig. 7), similar to the configuration of an LHC ring collimator. Each jaw will be guided by two passing-through shafts, which will allow for longitudinal displacements in case of elastic deformation.

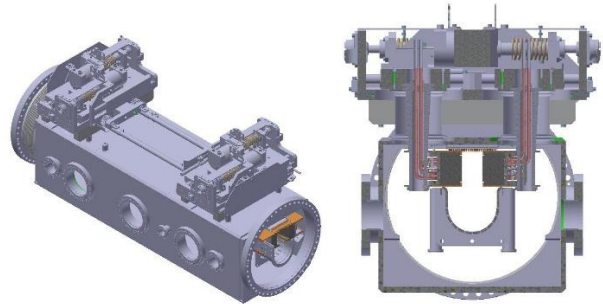

Figures 7: Jaw positioning mechanism by module and transverse-cut view of its attachments to the jaw.

By reducing the volume of the cavities present around the jaws and the lateral plate of the tank, the geometry is optimised, and the TDIS is able to damp high frequency modes [13].

By installing RF finger contacts between jaws and tank, jaws and RF screen, and between two consecutive jaws of different modules, the suppression of the low frequency modes is assured [13].

### CONCLUSIONS

The TDI is a beam intercepting device of crucial importance for the LHC machine protection.

Its upgrade, the TDIS, will not only cope with higher intensities and more localised HL-LHC beam impacts, but will improve the existing TDI weaknesses thanks to the experience acquired.

The low-Z material selection is subject to the validation of the graphite R4559 by the currently on going HiRadMat-28 experiment. The selected high-Z materials are AW6061 and CuCrZr.

The AW6061 jaw frame creates a rigid structure, allows for a more robust and direct fixation with the motors and withstands the stresses that the fast deposited energy generates on its structure. The clamped configuration CuNi cooling circuit with 4 channels can dissipate the heat load generated by the beam induce RF heating during operation.

The reduction of the volume of the cavities allows to damp a large number of high frequency modes, as the incorporation of several RF contacts allows to damp the low frequency modes.

The 3-module design allows for a simplified assembly procedure, installation, maintenance and storage.

## REFERENCES

- [1] B. Goddard, V. Kain, M. Lamont, “Function and operating conditions of the TDI absorber”, LHC-TDI-ES-0001, EDMS Document 508735, 2004.
- [2] I. Lamas Garcia et al. “TDI Spares Absorbing blocks, hBN v/s Graphite R4550”, WP14 meeting, 2015.
- [3] N. Biancacci, F. Caspers, J. Kuczerowski, A. Passarelli, B. Salvant, “Outcome of the TDI impedance bench measurements”, 215th Meeting of the LHC Machine Committee, 2015.
- [4] A. Grudiev, Impedance meeting, 2012.
- [5] C. Bracco et al. “Injection considerations for scrubbing run”, Operation meeting, 2015.
- [6] V. Kain, “Guidelines for beam parameters to be assumed for LIU and HL studies”, LIU meeting, 2016.
- [7] A. Lechner, “Preliminary design requirements for the TDIS”, WP14 meeting, 2015.
- [8] I. Lamas Garcia et al. “TDIS low density absorber materials thermomechanical simulations”, WP14 meeting, 2015.
- [9] F.L. Maciariello et al. “HRMT-28 experiment safety file”, 2015.
- [10] I. Lamas Garcia et al. “TDIS high Z blocks thermo-mechanical studies”, WP14 meeting, 2015.
- [11] I. Lamas Garcia et al. “TDIS Frame and CuNi cooling circuit thermo-mechanical studies, WP14 meeting, 2015.
- [12] I. Lamas Garcia et al. “TDIS cooling circuit thermal efficiency studies”, WP14 meeting, 2016.
- [13] B. Salvant et al. “TDIS impedance update”, WP14 meeting, 2016