

# TIME RESPONSE OF A GRIDDED X-RAY BEAM IONIZATION CHAMBER\*

Yahong Xu<sup>1</sup>, Zhihong Sun<sup>1,†</sup>, Doug Van Campen<sup>2</sup>, Chunlei Li<sup>3</sup>, W.J. Zhang<sup>3</sup> and Jeff Corbett<sup>2</sup>

<sup>1</sup> Donghua University, Shanghai, China

<sup>2</sup> SLAC National Accelerator Laboratory, Menlo Park, USA

<sup>3</sup> East China University of Science and Technology, Shanghai, China

## Abstract

Recently, Quick-Scanning Extended X-ray Absorption Fine Structure Spectroscopy (QEXAFS) has become an important tool for in-situ characterization of materials and measurement of associated electronic structure for where samples have a short life due to X-ray damage. In this case, the time response of the ionization chamber affects the measurement resolution and therefore overall performance of the QEXAFS system. Common parallel-plate ionization chambers have a step-response rise time of about 0.1 sec, which does not meet the requirements of QEXAFS. To speed up the response, we constructed a gridded ionization chamber with variable bias voltage and optional background gas (N<sub>2</sub> or He, respectively). To characterize the system we used a high-frequency beam chopper upstream of the ionization chamber and a high-speed, low-noise preamplifier to measure the step response of the chamber as a function of bias voltage and background gas conditions.

## INTRODUCTION

Since the Quick-scanning Extended X-ray Absorption Fine Structure Spectroscopy (QEXAFS) became an important tool for in-situ studies, the usage of it has become popular [1-4]. As is well known, XAFS is a very important tool for materials science since it can measure and characterize local atomic structure. This is beneficial for many fields such as biology, chemistry, electronics, geophysics, metallurgy and material science. However, when it comes to QEXAFS, time response is an important factor for the whole system. The time resolution mainly depends on the photon flux (intensity of incident beam), performance of monochromators, preamplifiers, the ionization chambers and the data acquisition system. In order to get a full EXAFS spectrum in less than 100 ms across several 100s of eV, we need to have a fast step response ionization chamber. By using the gridded ionization chamber, we realized a rise time down to several microseconds [5]. The rise time can be even less due to the limitation of the other factors such as the chopper speed as discussed in this paper.

## CHARACTERISTICS OF GRIDDED IONIZATION CHAMBERS

### Physical Construction

In some synchrotron radiation experiments, such as X-ray absorption spectroscopy, ionization chambers are used as a photon beam intensity monitor. Normally, ionization chambers consist of two parallel plates, which can collect the charge created by direct ionization within the gas by applying high voltage to create an electric field. The electrons and ions are collected by the cathode and anode, respectively. In the ionization chamber, the output signal can be measured from the positive or the negative electrode, so the drift of both electrons and ions contribute to the overall output signal. Drift velocity is an important parameter because it indicates how quickly the ions can be collected at the cathode. According to Ahmed (Physics and Engineering of radiation Detection, second edition, 2014), the ion velocity is proportional to the ratio of electric field and gas pressure as long as no breakdown occurs in the gas.

$$v_d = \mu_+ \frac{E}{P}$$

Here,  $v_d$  is the drift velocity of ions,  $\mu_+$  is the ion mobility in the gas ( $\mu_-$  is electron),  $E$  is the applied electric field and  $P$  is the gas pressure.

The ionization chamber output current is,

$$I(t) = \begin{cases} \frac{e}{d} * (\mu_+ + \mu_-) & 0 < t < t_- \\ \frac{e}{d} * \mu_+ & t_- < t < t_+ \\ 0 & \text{otherwise} \end{cases}$$

Because the drift velocity of ions is two or three orders of magnitude lower than that of electrons, the slow movement of ions affects the step response of the ionization chamber. If we can eliminate the influence of ions, we can increase the rise time of the ionization chamber response.

In order to improve the performance of ionization chamber, we made a gridded ionization chamber similar to Müller [5]. Referring to Fig.1, a metal grid is inserted between the two parallel electrodes. In this way, only

\* Work sponsored by US Department of Energy Contract DE-AC03-76SF00515, Office of Basic Energy Sciences and the China Scholarship Council.

† Corresponding author: zhsun@dhu.edu.cn

electrons can pass through the grid and make contribution to the output current signal. As soon as the electrons reach the grid, the current signal starts to register, which significantly changes the rise time of the ionization chamber. For our experiments, we tested the gridded ionization chamber with Nitrogen filling gas. Argon is considered as an ideal gas for gridded ionization chamber because it does not have negative ions by electron attachment [6].

$$I(t) = \begin{cases} \frac{e}{d} * \mu_- & t_G < t < t_- \\ 0 & \text{others} \end{cases}$$

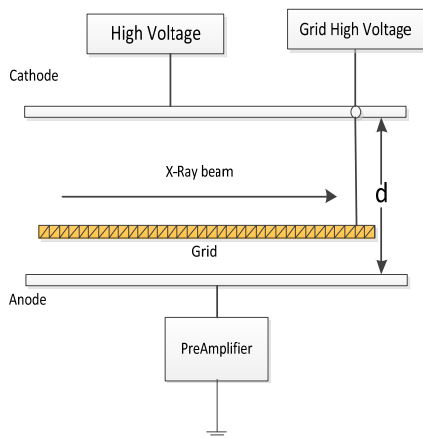

Figure 1: Structure of a gridded ionization chamber.

*Theoretical Step Response Analysis*

As a linear time invariant system, the behavior of the ion chamber (x-ray detector) can be described by its convolution kernel,  $h(t), g(t)$  which comes from the incident x-ray flux, and the output signal,  $y(t)$ .

$$y(t) = \int_{-\infty}^{+\infty} g(\tau)h(t - \tau)d\tau$$

Consequently, the ion chamber impulse response should provide a rise time as short as possible.

**EXPERIMENTS AND VERIFICATION**

In order to verify the performance of gridded ionization chamber, we measured the step response of the ionization chamber. The whole experiment consisted of a X-ray light source, fast-speed chopper, the gridded ionization chamber, a preamplifier and an oscilloscope (Fig. 2).

The fast chopper could produce hundred microseconds X-ray pulses with a rise time of a few microsecond. Here, we used a Thorlabs MC2000 chopper control and chopper wheel with 100 blades. The frequency was changed automatically with software on a computer. To reduce the rise time limitation of the pre-amplifiers, we use high-speed, low noise amplifiers (DHPCA-200 and DLPCA-100)[7], the rise time of which can be down to 700ns. In

the experiment, normally we used gains of  $2 \times 10^7 V/A$  and  $2 \times 10^8 V/A$  (rise time down to  $7\mu s$ ). With the fast amplifier, the influence of the current-to-voltage conversion stage was minimized.

The ionization chamber, we provided a high voltage to the top plate and a high voltage to the grid. A high electric field intensities minimizes recombination effects. According to ion transport dynamics Nitrogen [8-9], and electron drift velocity curves [10], the velocity of ions is proportional to field strength. Müller discussed how the applied voltage is independent in the rise time of response of ionization chamber [11]. Here, we chose an applied voltage for top plate and grid of -1000 V and -300V, respectively.

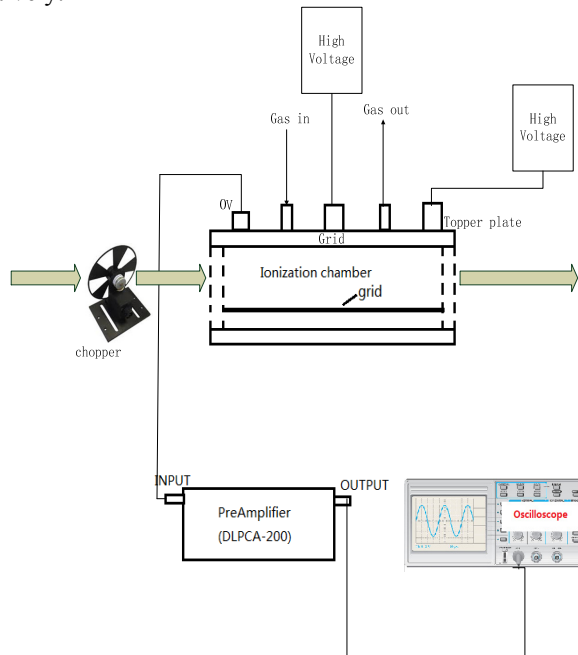

Figure 2: Measurement system configuration.

**EXPERIMENTAL RESULTS**

Preliminary ionization chamber experiments were performed at the Stanford Synchrotron Radiation Lightsource (SSRL) beamline 2-1 and 7-2 at the photon energy of 12000eV and  $N_2$  as the filling gas. We used different amplifiers and variable chopper frequencies for several tests. When we set the chopper frequency to 10kHz, the rise time of ionization chamber was observed as in Fig. 3 to be as fast as  $20 \mu s$ , which agrees well with theoretical analysis. In Fig. 3 (a) the chopper frequency is 10 kHz and in Fig. 3 (b) the frequency is 5 kHz. As a result, we believe a faster chopper and smaller photon beam cross-section will generate more promising results.

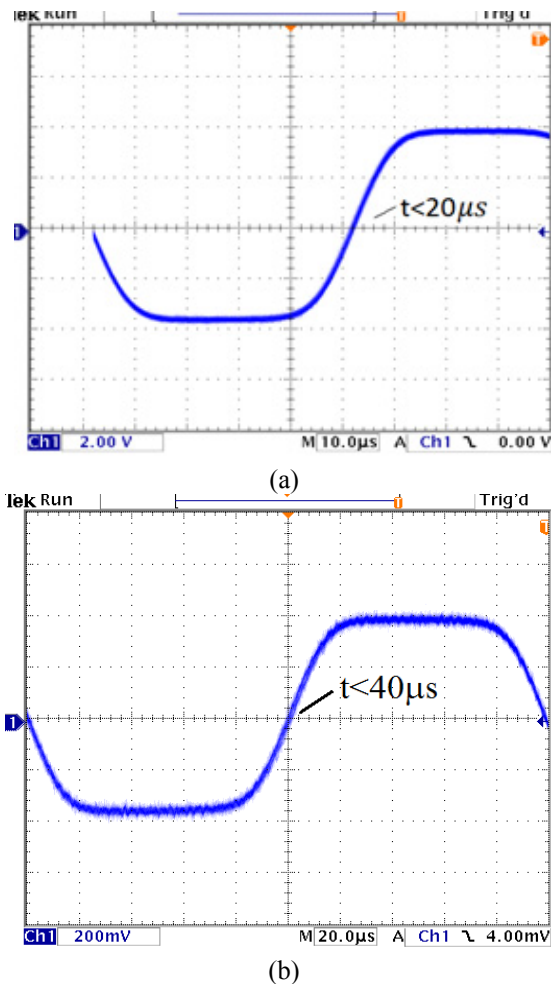

Figure 3: Rise time measurements with different chopper frequencies (a) 10,000Hz, and (b) 5,000Hz.

## CONCLUSION

In these experiments we first verified the performance of high-bandwidth pre-amplifiers for the fast ionization chamber measurements. The step response of amplifier met manufacturer specification. Fast rise time was recorded with  $N_2$  as the background gas. We then used fast photodiodes for x-ray detection to do repeat the measurements with 12kV X-rays on SSRL BL7-2, and it agrees with ion chamber. Since Argon does not generate ions in the future we will repeat the tests with a background Ar atmosphere.

Compared to  $N_2$ , when the filling gas is Helium, the signal is very weak so it is harder for the detector to identify the low-amplitude signal. As a result, the noise of the signal can be large. Research into how to further increase bandwidth and reduce noise in the system is the subject of future work.

A rapid-scan monochromator has been installed at Beamline 2-2. Future, testing will occur at this beamline.

## ACKNOWLEDGEMENTS

The authors would like to thank SSRL beamline scientist Bart Johnson for the help of our experiment. C. Li and

Y. Xu would like to acknowledge financial support from China Scholarship Council (CSC).

## REFERENCES

- [1] B. K. Teo and D. C. Joy, "EXAFS Spectroscopy Techniques and Applications", *Springer Science*, (1981).
- [2] R. Frahm, "Quick Scanning EXAFS: First experiments", *Nuclear Instruments and Methods in Physics Research*, 578 (1988).
- [3] Takahiro Wada, "Operando QEXAFS studies of Ni2P during thiophene hydrodesulfurization: direct observation of Ni—S bond formation under reaction conditions", *Journal of Synchrotron Radiation*, 19, pp. 205-209 (2012).
- [4] F. Cimini and R. Prins, "QEXAFS Investigation of the Particle Growth of PtRh Clusters Supported on NaY", *J. Phys. Chem.*, 101, pp. 5277-5284 (1997).
- [5] O. Müller, "Gridded ionization chamber for time resolved x-ray absorption spectroscopy", *Journal of Physics: Conference Series* 425 (2013).
- [6] O. Bunemann, "Design of grid ionization chambers", *Canadian Journal of Research*, Vol. 27, Section A (1978).
- [7] FEMTO, [Http://www.femto.de/en/products/current-amplifiers/variable-gain-up-to-200-mhz-dhpc.html](http://www.femto.de/en/products/current-amplifiers/variable-gain-up-to-200-mhz-dhpc.html)
- [8] Kazumichi Sato, "The behavior of Ionization Chambers under the Irradiation x-ray Beams", Spring-8 Annual Report 1997, 225 (1997).
- [9] Kazumichi Sato, "The behavior of Ionization Chambers and the Criterion of High Applied Voltage under the High Current Storage Ring Operation", Spring-8 Annual Report 1998 (1998).
- [10] E.D. Klema, "Drift Velocities of Electrons in Argon, Nitrogen, and Ar- $N_2$  Mixtures", (1950).
- [11] O. Müller, "Hard disk drive based microsecond x-ray chopper for characterization of ionization chambers and photodiodes", *Review of Scientific Instruments* 86, 035105 (2015).