

ENERGY CHIRP MEASUREMENTS BY MEANS OF AN RF DEFLECTOR: A CASE STUDY THE GAMMA BEAM SOURCE LINAC AT ELI-NP

L. Sabato*, University of Sannio, Benevento, Italy
 P. Arpaia, A. Liccardo, University of Naples Federico II, Napoli, Italy
 A. Mostacci, L. Palumbo, University of Rome La Sapienza, Roma, Italy
 A. Variola, INFN/LNF, Frascati (Roma), Italy

Abstract

RF Deflector (RFD) based measurements are widely used in high-brightness electron LINAC around the world in order to measure the ultra-short electron bunch length. The RFD provides a vertical kick to the particles of the electron bunch according to their longitudinal positions. In this paper, a measurement technique for the bunch length and other bunch properties, based on the usage of an RFD, is proposed. The basic idea is to obtain information about the bunch length, energy chirp, and energy spread from vertical spot size measurements varying the RFD phase, because they add contributions on this quantity. The case study is the Gamma Beam System (GBS), the Compton Source being built in the Extreme Light Infrastructure-Nuclear Physics (ELI-NP) facility. The ELEctron Generation ANd Tracking (ELEGANT) code is used for tracking the particles from RFD to the measurement screen.

INTRODUCTION

RFD or Transverse Deflecting Structure (TDS) [1] based measurements are widely used in high-brightness electron LINAC around the world in order to measure the ultra-short electron bunch length: at SLAC [2], at SPARC-LAB [3, 4], at DESY [5], at MIT PSFC [6], and so on. A RFD provides a transverse kick to the electron bunch introducing a relationship between the bunch longitudinal dimension (i.e. bunch length) and the bunch vertical dimension at a screen, placed after the RFD. Therefore, the electron bunch length can be obtained through vertical spot size measurements on a screen, placed after the RFD [7, 8], after an appropriate calibration measuring the vertical bunch centroid varying the deflecting voltage phase [9]. Such devices are very common in high brightness LINACs since they allow to achieve very good resolutions, lower than other state-of-the-art measurements, such Electro Optical Sampling [10].

The case study is the GBS electron LINAC at the ELI-NP [11], but it can be applied also to other high brightness LINAC [12]. The GBS at ELI-NP will be an advanced source of up to 20 MeV gamma rays based on Compton back-scattering, i.e. collision of an intense high power laser beam and a high brightness electron beam with maximum kinetic energy of about 720 MeV [13]. The GBS electron LINAC can run at a maximum repetition rate of 100 Hz [14] and, therefore, the specifications on the requested spectral density (10^4 photon/(eV·s)) cannot be achieved with single bunch

collisions at room temperature [13]. The final optimization foresees multiple bunch collisions, with trains of 32 electron bunches, 1 ps in length, and separated by 16 ns, distributed along a $0.5 \mu\text{s}$ RF pulse. An important diagnostic task for the beam quality is to measure the properties of the single bunch and the whole train of bunches [15].

The assumptions about the bunch properties at RFD entrance could be sources of systematic errors in bunch length measurements, for example assuming a negligible energy chirp [16] and negligible correlations between longitudinal and vertical plane, since they add contributions on the vertical spot size at screen placed after the RFD. In this paper, we propose a way to measure with the RFD not only the bunch length, but also energy chirp and energy spread. After reviewing the standard technique in the first section, we discuss the energy chirp and energy spread measurement in the following section. As an example, we discuss the ELEGANT [17] simulations of the proposed measurement for the GBS LINAC in the last section.

BUNCH LENGTH MEASUREMENT

Modeling the RFD as (i) a drift of length $L_{RFD}/2$, (ii) a vertical kicker, and (iii) another $L_{RFD}/2$ -long drift, where L_{RFD} is the mechanical length of the RFD, and assuming that (i) the vertical bunch centroid at RFD center, the longitudinal bunch centroid at RFD center, and the average of the particle vertical divergences are null, (ii) the bunch correlations between vertical and longitudinal planes, the energy chirp, and energy spread are negligible, the vertical spot size at screen after the RFD is [2, 3]:

$$\sigma_{y_s}^2(\varphi) = \sigma_{y_s,off}^2 + K_{cal}^2(\varphi)\sigma_{t_0}^2, \quad (1)$$

where φ is the deflecting voltage phase, $\sigma_{y_s,off}$ is the vertical spot size with RFD off [18], σ_{t_0} is the bunch length in seconds, and K_{cal} is the calibration factor and it can be calculated from vertical bunch centroid measurements at screen varying RFD phase [9]:

$$K_{cal} = 2\pi f_{RF} \frac{dC_{y_s}}{d\varphi}, \quad (2)$$

where f_{RF} is the deflecting voltage frequency and C_{y_s} is the vertical bunch centroid at screen [2, 3]:

$$C_{y_s} = LC_{rfd,a} \sin(\varphi), \quad (3)$$

where L is the distance between RFD center and the screen, $C_{rfd,a} = V_t/\langle E \rangle$, V_t is the deflecting voltage amplitude, and

* luca.sabato@unisannio.it

$\langle E \rangle$ is the average of the particle energies. Equation (1) underlines that the RFD provides a transverse kick to the electron bunch introducing a relationship between the bunch length and the bunch vertical dimension at the screen, placed after the RFD. Every step of the model of the bunch length measurement production, based on the eqs. (1), (2), and (3), is explained in [16].

ENERGY CHIRP AND ENERGY SPREAD

Basic Idea

Assuming that (i) the correlations between the vertical and the longitudinal planes at RFD entrance are negligible, (ii) the particle energy can be written in Taylor series stopped at first order around the particle energy average $\langle E \rangle$, and (iii) considering an RFD phase range small and centered in 0 rad (or π rad), therefore, the calibration can be considered constant, $K_{cal}(\varphi) \approx K_{cal}(0)$ (or $K_{cal}(\varphi) \approx -K_{cal}(\pi)$) and $\tan(\varphi) \approx \varphi$ for $\varphi \approx 0$ (or $\varphi \approx \pi$), the vertical spot size at screen is:

$$\sigma_{y_s}^2(\varphi) = \sigma_{y_s,off}^2 + K_{cal}^2(0) \left[\sigma_{t_0}^2 - \frac{\sigma_{t_0\delta}}{\pi f_{RF}} \varphi + \frac{\sigma_{\delta}^2}{(2\pi f_{RF})^2} \varphi^2 \right], \quad (4)$$

where σ_{δ} is the energy spread and $\sigma_{t_0\delta}$ is the energy chirp: the covariance between particle position and energy $\delta_i = (E_i - \langle E \rangle) / \langle E \rangle$ (i.e. the element 5,6 of the bunch matrix [19]). The third term and the fourth term are the contributions of the energy chirp and spread on the vertical spot size at screen with RFD on, respectively. They can be considered sources of systematic error of bunch length measurements. In particular, the effect of the energy chirp on bunch length measurements is highlighted in [16].

Furthermore, these contributions can be used in order to obtain information about the energy chirp and spread from vertical spot size measurements varying the deflecting voltage phase. In particular, Eq. (4) is a quadratic polynomial of the variable φ . The coefficients of the quadratic polynomial p_i can be calculated by means of a polynomial fit of the vertical spot size measurements squared at screen varying the RFD phase around 0° (or 180°) and, then, the energy spread, the energy chirp, and the bunch length can be calculated, respectively:

$$p_1 = \frac{K_{cal}^2(0)}{(2\pi f_{RF})^2} \sigma_{\delta}^2, \quad \sigma_{\delta,m} = \sqrt{p_1} \frac{2\pi f_{RF}}{|K_{cal}(0)|}, \quad (5)$$

$$p_2 = -2 \frac{K_{cal}^2(0)}{2\pi f_{RF}} \sigma_{t_0\delta}, \quad \sigma_{t_0\delta,m} = -p_2 \frac{2\pi f_{RF}}{2K_{cal}^2(0)}, \quad (6)$$

$$p_3 = \sigma_{y_s,off}^2 + K_{cal}^2(0) \sigma_{t_0}^2, \quad \sigma_{t_0,m} = \frac{\sqrt{p_3 - \sigma_{y_s,off}^2}}{|K_{cal}(0)|}. \quad (7)$$

Some further considerations from Eq. (4) can be made. Firstly, in the vertical spot size, the first term should be non-dominant with respect to the other terms, because the other terms include information about the measurands: bunch

length (i.e., σ_{t_0}), energy chirp (i.e., $\sigma_{t_0\delta}$), and energy spread (i.e., σ_{δ}). At this aim, (i) K_{cal} can be increased (namely, the distance between RFD and the screen and/or the deflecting voltage amplitude), and (ii) $\sigma_{y_s,off}$ can be decreased, by means of vertical focusing quadrupoles placed before RFD. Moreover, the second, the third, and the fourth term of Eq. (4) should have a non-negligible contribution on vertical spot size, in order to obtain information of every measurand from vertical spot size measurements. These contributions include the same coefficient K_{cal}^2 , therefore, for a fixed deflecting voltage frequency, the variations of the distance between RFD and the screen and/or the deflecting voltage amplitude do not alter the contribution of each term on the vertical spot size. For these reasons, the proposal measurement technique can be applied only in the cases in which the investigated measurands give a non-negligible contribution to the vertical spot size, i.e. for bunch with suitable proprieties in terms of length, energy chirp, and energy spread.

Model of Measurement Production

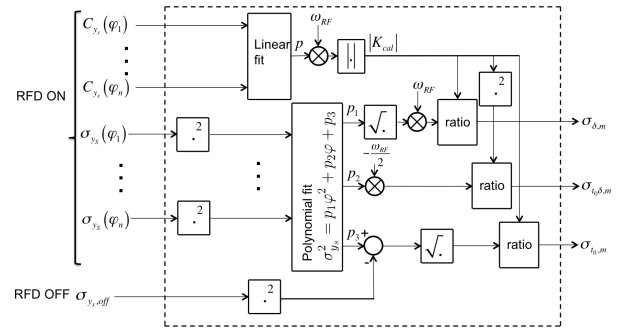

Figure 1: Model of measurement production of the bunch length σ_{t_0} , energy chirp $\sigma_{t_0\delta}$, and energy spread σ_{δ} .

These considerations suggest a measurement technique based on the usage of an RFD not only for the standard measurand, i.e. the bunch length, but also for the energy chirp and spread (see Fig. 1). First of all, the model of the production of the bunch length measurement relies on measurement acquisition with the following operations:

1. RFD off: measure the vertical spot size at screen $\sigma_{y_s,off}$;
2. RFD on: measure the vertical bunch centroid at screen for different values of RFD phase φ_i (centered in 0° or 180°) $C_{y_s}(\varphi_i)$;
3. RFD on: measure the vertical spot size at screen for different values of RFD phase φ_i (centered in 0° or 180°) $\sigma_{y_s}(\varphi_i)$.

Secondly, the data elaboration consists of the following steps:

1. calculate the slope p of the plot vertical bunch centroid at screen versus φ by means of a linear fit, and then calculate the calibration factor K_{cal} by multiplying the deflecting voltage angular frequency by the slope p Eq. (2);

- calculate the coefficients p_1 , p_2 , and p_3 of the quadratic polynomial of the variable φ given by the squared values of vertical spot size at screen by means of a polynomial fit Eq. (4);
- measure the bunch length $\sigma_{t_0,m}$, the energy chirp $\sigma_{t_0\delta,m}$, and the energy spread $\sigma_{\delta,m}$ by means of Eqs. (7), (6), and (5), respectively.

This model of measurement production requires new steps in the measurement acquisition and in the data elaboration compared to the model of bunch length measurement production in [16]. Firstly, different vertical spot size measurements are needed and not only one measurement (or two measurements in order to cancel the correlations between vertical and longitudinal planes at RFD entrance). Secondly, a polynomial fit of the squared values of the vertical spot size at screen varying the RFD phase is required. Furthermore, the energy chirp and spread are obtained applying Eqs. (6) and (5), respectively.

GBS ELECTRON LINAC

Simulation Conditions

A bunch composed of 50,000 particles with a charge of 250 pC was tracked by means of ELEGANT code from the RFD to the screen of GBS electron LINAC, placed between the first and the second C-band accelerating section of GBS electron LINAC [13]. The distance between RFD center and the screen L is 1.1380 m. The deflecting voltage amplitude V_t and frequency are 1 MeV and 2.856 GHz, respectively. The GBS electron LINAC bunch parameters of vertical and longitudinal planes at RFD entrance are (in rms): $\sigma_y = 354 \mu\text{m}$, $\sigma_{y'} = 57.6 \mu\text{rad}$, $\sigma_{yy'} = -1.99 \cdot 10^{-2} \text{ mm}\cdot\text{mrad}$, $\langle E \rangle = 118 \text{ MeV}$, $\sigma_{t_0} = 0.9118 \text{ ps}$, and $\sigma_{t_0\delta} = 5.33 \text{ fs}$. In the case of the GBS electron LINAC the contribution of the energy chirp on the vertical spot size is non-negligible, on the contrary the contribution of the energy spread is negligible [16]. For these reasons the squared values of the vertical spot size varies linearly with the RFD phase, because the third term of Eq. (4) can be neglected, therefore the information on the bunch length and the energy chirp can be obtained by means of a linear fit.

Numerical Results

In Figs. 2 and 3, the vertical bunch centroid and spot size at screen in a RFD phase, ranging between -10° and 10° , are reported, respectively. From the vertical bunch centroid measurements, the calibration factor can be calculated Eq. (2): $K_{cal}(0) = (173.12 \pm 0.06) \mu\text{m}/\text{ps}$. The uncertainty on the calibration factor is due to the linear fit of the vertical bunch centroid versus RFD phase. The approximation of a constant calibration factor in the RFD phase range lead to a negligible relative error ($<1.5\%$). The results of the application of the proposed model of measurement production are the following: $\sigma_{t_0,m} = (0.9086 \pm 0.0005) \text{ ps}$, $\sigma_{t_0\delta,m} = (5.07 \pm 0.14) \text{ fs}$. The bunch length and energy chirp measurements are affected by the uncertainties due to the calibration factor and

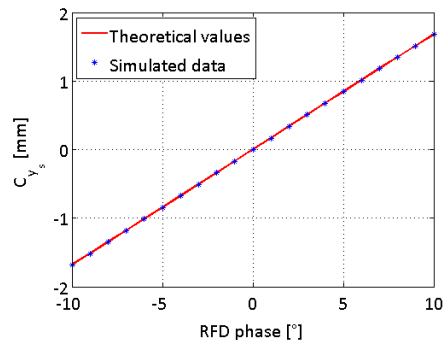

Figure 2: Vertical bunch centroid at screen around the RFD phase of 0° . Simulated data in blue stars, theoretical values Eq. (3) in red line.

the linear fit of the vertical spot size at screen versus RFD phase, calculated by means of the uncertainty propagation equation. The relative error on the bunch length and on energy chirp measurements are below 0.4% and 5%, respectively. The requirements for the camera in this case study are: (i) a field of view of at least 5.5 mm and (ii) a resolution of at least $54 \mu\text{m}$.

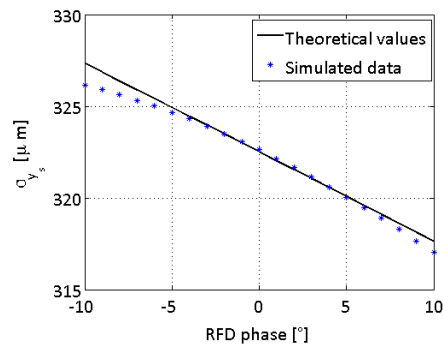

Figure 3: Vertical spot size at screen around the RFD phase of 0° . Simulated data in blue stars, theoretical values Eq. (4) in black line.

CONCLUSION

A measurement technique for the bunch length and other bunch proprieties, based on the usage of an RFD, is presented. The basic idea is to obtain information about bunch length, energy chirp, and energy spread from vertical spot size measurements varying the RFD phase, because they add contributions on this quantity. The proposed measurement technique is applied at the GBS electron LINAC at ELI-NP and the numerical results, obtained by means of ELEGANT code, are presented. The relative error on the bunch length and on energy chirp measurements are below 0.4% and 5%, respectively. The requirements for the camera in this case study are: (i) a field of view of at least 5.5 mm and (ii) a resolution of at least $54 \mu\text{m}$. The results of this paper can be useful for high brightness LINAC using energy chirped electron beams, e.g. [20].

REFERENCES

- [1] A. Cianchi *et al.*, “Observations and diagnostics in high brightness beams,” *Nuclear Instruments and Methods in Physics Research Section A: Accelerators, Spectrometers, Detectors and Associated Equipment*, vol. 829, pp. 343–347, 2016.
- [2] R. Akre, L. Bentson, P. Emma, and P. Krejcik, “A transverse rf deflecting structure for bunch length and phase space diagnostics,” in *Particle Accelerator Conference, 2001. PAC 2001. Proceedings of the 2001*, vol. 3. IEEE, 2001, pp. 2353–2355.
- [3] D. Alesini *et al.*, “Rf deflector design and measurements for the longitudinal and transverse phase space characterization at sparc,” *Nuclear Instruments and Methods in Physics Research Section A: Accelerators, Spectrometers, Detectors and Associated Equipment*, vol. 568, no. 2, pp. 488–502, 2006.
- [4] D. Filippetto *et al.*, “Phase space analysis of velocity bunched beams,” *Physical Review Special Topics-Accelerators and Beams*, vol. 14, no. 9, p. 092804, 2011.
- [5] M. Hüning *et al.*, “Observation of femtosecond bunch length using a transverse deflecting structure,” in *Proceedings of the FEL*, 2005.
- [6] J. Haimson, “Longitudinal phase space measurements of short electron bunches using a 17 ghz circularly polarized beam deflector,” in *AIP Conference Proceedings*, vol. 737. AIP, 2004, pp. 95–108.
- [7] R. H. Miller, R. F. Koontz, and D. D. Tsang, “The slac injector,” *IEEE Transactions on Nuclear Science*, vol. 3, no. 12, pp. 804–808, 1965.
- [8] X. J. Wang, “Producing and measuring small electron bunches,” in *Particle Accelerator Conference, 1999. Proceedings of the 1999*, vol. 1. IEEE, 1999, pp. 229–233.
- [9] D. Alesini *et al.*, “Sliced beam parameter measurements,” in *Proceedings of DIPAC*, 2009.
- [10] R. Pompili *et al.*, “First single-shot and non-intercepting longitudinal bunch diagnostics for comb-like beam by means of electro-optic sampling,” *Nuclear Instruments and Methods in Physics Research Section A: Accelerators, Spectrometers, Detectors and Associated Equipment*, vol. 740, pp. 216–221, 2014.
- [11] A. Giribono *et al.*, “6d phase space electron beam analysis and machine sensitivity studies for eli-np gbs,” *Nuclear Instruments and Methods in Physics Research Section A: Accelerators, Spectrometers, Detectors and Associated Equipment*, 2016.
- [12] D. Alesini *et al.*, “Status of the sparc project,” *Nuclear Instruments and Methods in Physics Research Section A: Accelerators, Spectrometers, Detectors and Associated Equipment*, vol. 528, no. 1, pp. 586–590, 2004.
- [13] O. Adriani *et al.*, “Technical design report eurogammas proposal for the eli-np gamma beam system,” *arXiv preprint arXiv:1407.3669*, 2014.
- [14] A. Bacci *et al.*, “Electron linac design to drive bright compton back-scattering gamma-ray sources,” *Journal of Applied Physics*, vol. 113, no. 19, p. 194508, 2013.
- [15] A. Cianchi *et al.*, “Six-dimensional measurements of trains of high brightness electron bunches,” *Physical Review Special Topics-Accelerators and Beams*, vol. 18, no. 8, p. 082804, 2015.
- [16] L. Sabato *et al.*, “Effects of energy chirp on bunch length measurement in linear accelerator beams,” *Measurement Science and Technology*, 2017. [Online]. Available: <https://doi.org/10.1088/1361-6501/aa6c8a>
- [17] M. Borland, “Elegant: A flexible sdds-compliant code for accelerator simulation,” Argonne National Lab., IL (US), Tech. Rep., 2000.
- [18] L. Sabato *et al.*, “Metrological characterization of the bunch length system measurement of the eli - np electron linac,” in *Proc. 14th IMEKO TC10, Milan, Italy, June 2016*, pp. 203–208.
- [19] H. Wiedemann, *Particle accelerator physics*. Springer, 2007.
- [20] G. Marcus *et al.*, “Time-domain measurement of a self-amplified spontaneous emission free-electron laser with an energy-chirped electron beam and undulator tapering,” *Applied Physics Letters*, vol. 101, no. 13, p. 134102, 2012.