

# ATOMIC LAYER DEPOSITION OF NIOBIUM NITRIDE FROM DIFFERENT PRECURSORS

P. Pizzol<sup>1,2</sup>, J. W. Roberts<sup>2</sup>, J. Wrench<sup>2</sup>, O.B. Malyshev<sup>1</sup>, R. Valizadeh<sup>1</sup>, P. R. Chalker<sup>2</sup>

<sup>1</sup>ASTeC, STFC Daresbury Laboratory, Warrington, UK

<sup>2</sup>Department of Material Science, University of Liverpool, Liverpool, UK

## Abstract

Advancements in technology have taken bulk niobium cavities close to their theoretical operational limits of 45 MV/m, pushing the research to explore novel materials, such as niobium based alloys. Theoretical studies suggest that a composite material composed of alternative superconductor / insulator multilayers would surpass the bulk niobium limits [1].

Chemical vapour deposition (CVD) can deposit microns thick Nb films in less than an hour, at the expense of precise thickness control. Atomic layer deposition (ALD), instead, even if considerably slower than CVD can be used in applications where the thickness of the deposited layers needs to be controlled with a resolution down to the nanometer.

This article presents the preliminary results obtained by using plasma assisted ALD techniques to deposit NbN based compounds starting from chlorinated precursors and organic ones, and the design for a new deposition system currently being built at the Daresbury Laboratories. The samples obtained are characterized via XPS and ellipsometry. Growth was achieved, but at lower rates than expected. Contamination in the films was found, due to deposition temperatures too low and oxygen contamination in the system.

## INTRODUCTION

Recent works by Gurevitch [1] and Kubo [2] on superconductor – insulator – superconductor systems have highlighted the need for a very high degree of control over the thickness of the layers that will make up these materials.

Keeping in mind that the final goal would be to coat a copper cavity, if this control can be achieved with Physical Vapour Deposition (PVD) and the use of High Power impulse magnetron sputtering (HiPims), it would still be challenging to coat a complex shape such as a cavity.

While Chemical Vapour Deposition (CVD) can provide quality films deposited over large surface areas with high geometric ratios (such as elliptical cavities or crab cavities) in short time frames (few microns of thickness of pure Nb per hour of deposition), controlling such thickness to the nanometer scale could prove very difficult. Atomic layer deposition (ALD) is the evolution of CVD and can provide the degree of control needed to allow the deposition of complex structures such as S – I – S with very precise thicknesses. The key is the precursors selection: the wrong combination of precursors and deposition parameters may cause contaminations or non – uniform depositions. In this paper we present our results obtained

by using an inexpensive inorganic Nb precursor and a more expensive metal organic Nb based precursor (MOCVD).

## EXPERIMENTAL SETUP

The experiments presented were conducted on an Oxford Instruments opAL<sup>®</sup> plasma enhanced atomic layer deposition facility. The instrument allows the use of five different precursor containers and four separate coreagent gases.

The chamber (Fig. 1) contains a heater plates capable of reaching 450 °C; the reactive gases can be fed in the top part the reactor where a RF plasma can be generated and pulsed according to the desired deposition parameters.

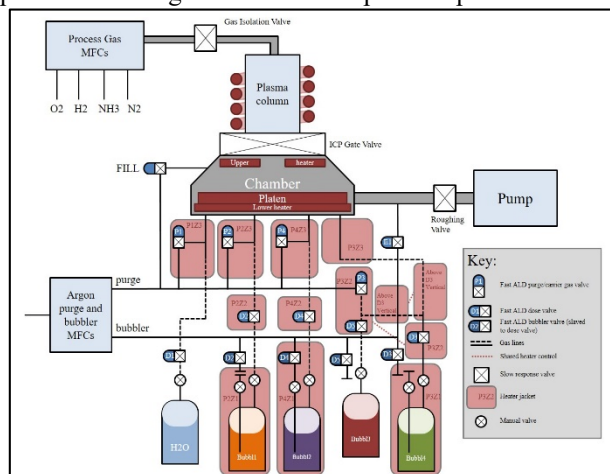

Figure 1: PEALD reactor schematic.

The thickness of the films obtained has been measured by ellipsometry: a light of a known polarization is shone on the surface of the coated samples and the changes in polarization correlate to the thickness of the films.

## NbN from Chlorinated Precursor Depositions

Niobium pentachloride (99% - Sigma Aldrich) has been explored first as a precursor for the deposition of niobium nitride because of previous experience ([3], [4]). The NbCl<sub>5</sub> is contained in a stainless steel two legged bubbler connected to the deposition facility and under argon atmosphere. The bubbler is purged before the deposition to reach the system base pressure, so to avoid any sudden change in pressure during the deposition which may hinder the uniformity of the growth. Different temperatures were used, but no growth was seen below 115 °C, which was then chosen as the growth temperature for this batch of samples. Nitrogen gas plasma was used as the source of nitrogen, mixed with hydrogen gas to pro-

vide the reduction of NbCl<sub>5</sub>. The gases were introduced in the plasma generation area above the chamber with a ratio of N<sub>2</sub> – H<sub>2</sub> of 5:1.

Silicon (100) samples were used as substrates.

The Temperature of the substrate and number of cycles were varied as deposition parameters, as shown in table.

### NbN from Metal Organic Precursor Depositions

Tris(diethylamido)(tert-butylimido)niobium (TBTDEN) (99% - Sigma Aldrich) has been used as a precursor for the deposition of niobium nitride films. The temperature of the substrate was kept constant during the depositions at 300 °C, as suggested in literature [5]. As with the NbCl<sub>5</sub> depositions, the bubbler is purged before the depositions to avoid pressure spikes once started. The temperature of the bubbler and the doses were varied during the experiments. Silicon (100) and glass (microscope slides) were used as substrates.

## RESULTS AND DISCUSSIONS

### NbN from Chlorinated Precursor Depositions

Table 1 shows the growth parameters and results for the experiments conducted using the chlorinated precursor. One cycle was as follows: the argon gas was set at 100 sccm for 5 s, followed by a NbCl<sub>5</sub> pulse of 2 s, then purged for 5 s. The Ar was then set to 0, while the N<sub>2</sub> to 50 sccm and the H<sub>2</sub> to 10 sccm for 4 s. The plasma was therefore ignited at 300W for 3 s. The N<sub>2</sub> and H<sub>2</sub> were then reduced to 0 sccm while the Ar was set to 100 sccm for 5 s to close the cycle.

Table 1: Depositions from NbCl<sub>5</sub>

Sample	Growth Temp (°C)	Cycles	Thickness (nm)	Growth rate (nm / cycle)
1	300	100	3.67	0.037
2	350	100	3.73	0.037
3	350	500	11.8	0.024
4	350	100	3.86	0.039
5	400	1000	28.76	0.029
6	400	200	7.58	0.038
7	450	100	2.36	0.024
8	450	700	20.1	0.029

The results show an average growth rate of 0.03 nm per cycle, which is lower than the reported one of 0.06 nm per cycle. This could be attributed to a low quantity of precursor being bled into the deposition chamber, but system limits prevented us from raising this any further.

According to literature, the higher the deposition temperature the less contaminants would be left behind in the film, especially chlorine coming from the reduction of the Nb.

To verify the amount of contaminants, the samples deposited at the highest temperatures achievable in this deposition system were analysed with XPS X-Ray photo-

electron spectroscopy. Samples 5, 6 and 8 were therefore investigated. Sample 5 was labelled “400 °C cold” while 6 “400 °C hot” because the former was extracted from the chamber when at 80 °C, while the latter was taken out of the system while the heating plate was still hot. Sample 7 was similarly to sample 1114 extracted once the system had cooled to 80 °C, hence why “450 °C cold”. The lower temperature of extraction should limit the oxidation of the films once exposed to air.

From the XPS results, all the samples exhibited N 1s peak at around 397 eV, which shows that nitrogen is present in the film.

In the 200 – 210 range all the samples show a peak at 206.8, indicating Nb<sub>2</sub>O<sub>5</sub>. The broadening towards 209.4 eV is also indicative of Nb<sub>2</sub>O<sub>5</sub>. For “450 oC Cold”, the shoulder at 204.4 eV suggests shifting towards NbN though there is clearly a mixture of the oxide film as well.

Cl presence would be prominent around 198-200 eV, where a small wide peak can be noted.

The effect on the cooling temperature seems to be of little impact on the composition of the films, since all of them show the presence of the oxide phase.

These results are explained by the nature of the reactor: the system had been used previously for depositions of oxide materials for semiconductors, contributing therefore a considerable presence of oxygen. This, together with the fact that temperature required to achieve the complete reduction of NbCl<sub>5</sub> (above 500 °C) is not achievable in this system (see Fig. 2), shows that this deposition system may not produce satisfying result if used with Cl based halogen precursors.

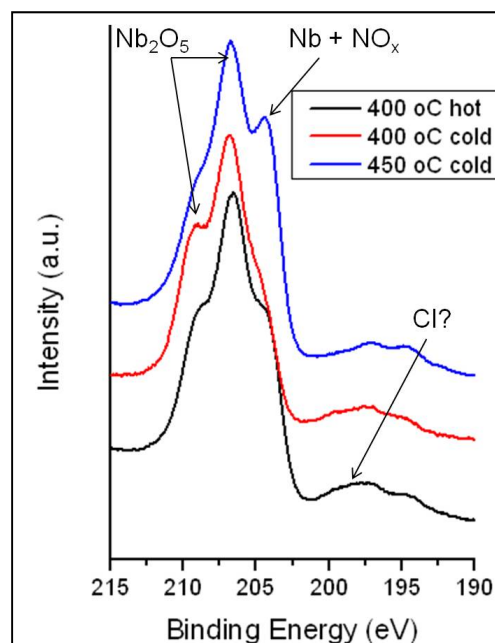

Figure 2: XPS analysis of depositions from NbCl<sub>5</sub>

### NbN from Metal Organic Precursor Depositions

Once verified that the inorganic precursor was not suited to the system available, a metal organic precursor was chosen.

Tris(diethylamido)(tert-butylimido)niobium (Nb - TBTDEN) has been previously used to deposit NbN, since its liquid form should allow a better transfer from the bubbler to the chamber and, since it's an organic compound, it should react at lower temperatures than its inorganic counterpart. The precursor has a few drawbacks after all: it's considerably more expensive than the inorganic precursor (a factor 100), and, being organic, it may decompose if heated too much.

The bubbler temperature was therefore set at 70 °C for the first deposition and increased by 10 °C for each following run.

Table 2: Deposition from Nb-TBTDEN

Precursor Temp (°C)	Cycles	Nitrogen flow (sccm)	Hydrogen flow (sccm)	Growth (nm)
70	50	60	-	0.3
80	50	60	-	0.3
90	50	60	-	0.3
100	50	60	-	2
105	50	60	-	3
110	50	60	-	4.7
110	400	60	-	12
110	400	60	10	17

Table 2 shows the growth parameters for the metal organic precursor growth attempts. The precursor is contained in a single leg bubbler, which means that there is no way to push the precursor out of the bubbler by using a carrier gas. The vapour pressure of the precursor has to be high enough to allow the precursor to reach the chamber, and this seems to be achieved only above 105 °C (Fig. 3).

The use of plasma generated purely by N<sub>2</sub> also seems to be insufficient to allow the reaction with the precursor, which is why H<sub>2</sub> was added in the plasma. This has led to an increase in the deposition rate to 0.04 nm per cycle.

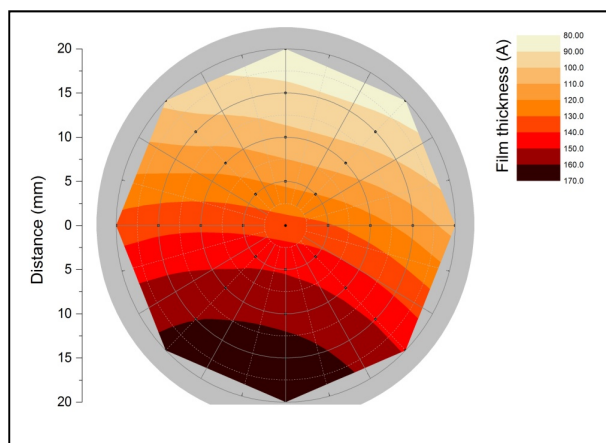

Figure 3: Si substrate thickness distribution.

Chemical characterization of the sample is going to be performed in the upcoming weeks, to verify the nature of the deposited film.

The growth rate is still low, suggesting that the deposition parameters could be improved. This was not possible in the time frame we had at our disposal to utilize the instrument.

### New ALD System Development.

The opAL® plasma enhanced atomic layer deposition facility has proven useful to explore the two precursors at our disposal. From the experiments it has been shown that, for the samples obtained from the NbCl<sub>5</sub> precursor, the heating budget at our disposal is too low to produce contamination free samples and adding the ever present oxygen contamination it is not possible to conduct any further work on it. Further studies are being conducted on the MOCVD sample to evaluate this hypothesis.

A new system is therefore being developed to improve on the issues aforementioned: by using a leak tight UHV chamber with a base pressure of 10<sup>-7</sup> mbar the oxygen contamination should be reduced to negligible levels. By using a heater capable of reaching 900 °C the chlorine contamination should also disappear, allowing the use of the NbCl<sub>5</sub> precursor.

Some preliminary studies and simulations (Fig. 4) have been conducted on the chamber size and flow dynamics by using ANSYS *Fluent*.

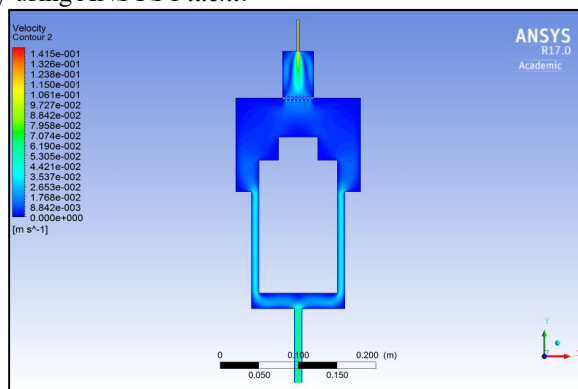

Figure 4: *Fluent* gas flow simulation of new chamber

## CONCLUSIONS

The use of the commercially available opAL® plasma enhanced atomic layer deposition system has not allowed the deposition of NbN from the halogen Nb precursors, while it has shown promise with the MOCVD precursor. Further investigations are needed on the MOCVD based samples to determine the chemical composition. On these results, a new reactor will soon be commissioned at the Daresbury Laboratories to overcome the limitations incurred.

## ACKNOWLEDGEMENTS

We would like to thank Prof Paul Chalker for the time allowed on the ALD instrument, Dr Joseph Roberts and Dr Jacqueline Wrench for their work, the University of Liverpool and the STFC UK for providing funding for Paolo's research.

**REFERENCES**

- [1] A. Gurevich, *APL*, vol. 88, p. 012511, (2006).
- [2] T. Kubo, *Superconductor Science and Technology*, vol. 30, no. 2, p. 023001, 2016.
- [3] P. Pizzol *et al.*, in *Proc. SRF'2015*, paper TUPB038 (2015).
- [4] P. Pizzol, P. Chalker, T. Heil *et al.*, in *Proc. IPAC'16*, paper WEPMB056 (2016).
- [5] M. Ziegler, L. Fritsch, J. Day *et al.*, *Superconductor Science and Technology*, vol. 26, no. 2, p. 025008, 2012.