

THE MYRRHA-RFQ – STATUS AND FIRST MEASUREMENTS*

H. Podlech[†], K. Kümpel, C. Lorey, P. Schneider, N. Petry, A. Schempp, IAP, Frankfurt, Germany
 C. Zhang, GSI, Darmstadt, Germany
 A. Bechtold, NTG Neue Technologien GmbH, Gelnhausen, Germany

Abstract

The MYRRHA project requires a proton linac with an energy of 600 MeV with a beam current of up to 4 mA in cw operation. As first RF structure a 176 MHz 4-Rod RFQ has been chosen because of tuning possibilities, maintenance, lower capital costs and technological risk compared to a 4-Vane-RFQ. The aim of beam dynamics design was to preserve excellent beam quality and to reduce the creation of halo particles especially in the longitudinal plane. Using the NFSP (New Four-Section Procedure) with a soft and symmetric pre-bunching with full 360° acceptance it was possible to reach the requirements. The simulated transmission of the 4 m long RFQ is close to 100%. The electrode voltage has been chosen to 44 kV which gives enough transverse focusing but limits the required RF losses to about 25 kW/m. The cooling has been optimized for reliable operation and a new method of dipole compensation has been applied. The RFQ has been fully constructed and is presently prepared for power tests. The paper describes the status of the RFQ and first measurements.

INTRODUCTION

The European MYRRHA Project (Multi purpose hYbrid Research Reactor for High-tech Applications) which will be realized at SCK • CEN (Mol, Belgium) aims to demonstrate the feasibility of large scale transmutation (s. Figure 1). Figure 1 shows the conceptual layout of the MYRRHA project and Table 1 summarizes the main parameters. As driver a 600 MeV, 2.4 MW cw proton linear accelerator is foreseen [1]. In a first step the construction of the 100 MeV section has started. The low energy section (17 MeV injector) [2] of the MYRRHA linac is the most critical part with respect to emittance growth and technological challenge. It consists of an ECR-source, a compact solenoid based LEBT, a 4-Rod-RFQ and 16 rt CH-cavities [3] (s. Figure 2). Additionally the MYRRHA linac has to be very reliable with MTBF (beam trips longer than 3 s) of larger than 250 h. These requirements have triggered the development of a new class of cw 4-Rod RFQ accelerators.

RFQ DESIGN

The design goal for the RFQ was to provide good beam quality with RF parameters which are well below the present limits of technology. Based on the above-mentioned choices and considerations, a new beam dynamics design was made

* Work supported by BMBF Contr. No. 05P15RFRBA, EU H2020 Contr. No 662186 (MYRTE)

[†] h.podlech@iap.uni-frankfurt.de

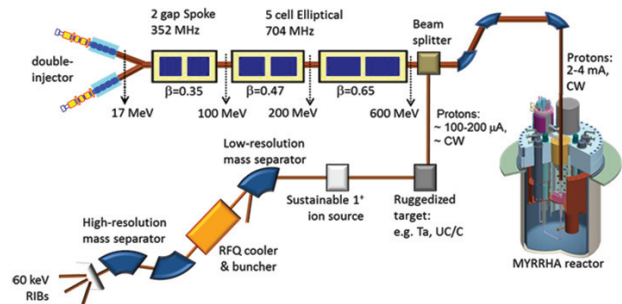

Figure 1: Conceptual layout of the MYRRHA.

Table 1: Parameters of the MYRRHA Project

| Particles | protons | |
|-------------------|---------|-------------|
| Energy | MeV | 600 |
| f | MHz | 176.1–704.4 |
| duty factor | % | 100 (cw) |
| I | mA | 4 |
| Beam power | MW | 2.4 |
| MTBF | h | 250 |
| Energy stability | % | ±1% |
| Current stability | % | ±2% |
| Reactor power th | MW | ≈60 |
| k _{eff} | | ≈0.95 |

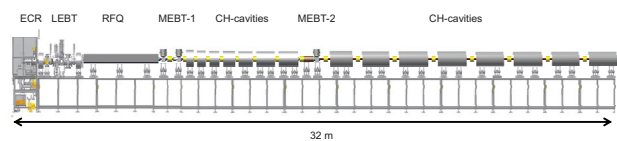

Figure 2: Conceptual layout of the MYRRHA 17 MeV Injector.

for the RFQ, following an unconventional approach, the so-called New Four-Section Procedure (NFSP), which is an efficient method for designing modern high-intensity, high-duty-factor RFQs [4]. The NFSP approach can be mainly distinguished by the following features:

- The NFSP approach varies the focusing strength B according to the changing space-charge situation along the RFQ
- The “pushed” prebunching in the traditional method is replaced by a soft and symmetric prebunching with a full 360° phase acceptance, which can eliminate an important source of potential unstable particles
- The main-bunching section can be performed more quickly to keep the structure compact. During the whole process, the transverse and longitudinal forces

are always balanced, so good beam quality can be achieved

Special care has been taken to avoid longitudinal tails to avoid particle losses in the high energy part of the main linac. The electrode voltage has been set to a moderate value of 44 kV to limit the thermal load during cw operation.

The estimated rms input emittance (normalized) given at the RFQ input has been assumed to 0.2π mm mrad. This value has been already confirmed by measurements. The MYRRHA RFQ has 244 accelerating cells and a total electrode length of about 4 m (see Table 2). The simulated transmission is 98.6% [5].

Table 2: Parameters of the MYRRHA RFQ

| RF structure | | 4-Rod RFQ |
|----------------------------|---------------|-----------|
| A/q | | 1 |
| f | MHz | 176.1 |
| E_{in} | keV | 30 |
| E_{out} | MeV | 1.5 |
| U | kV | 44 |
| R_p | k Ω m | 75 |
| L | m | 4 |
| P_c | kW | 103 |
| I | mA | 5 |
| Cells | | 244 |
| m_{max} | | 2.2 |
| RF cells | | 39 |
| $\epsilon_{in, rms, norm}$ | π mm mrad | 0.2 |
| T | % | 98.6 |

RF structure. The cooling has been significantly improved compared to previous 4-Rod RFQ-accelerators. New fabrication techniques have been developed using thick copper plating to create optimized cooling channels (s. Fig. 3). The electric contact between tuning plates and stems has been improved using silver sheets which are pressed by wedges. A prototype cavity has been tested with power levels up to 120 kW/m cw. The MYRRHA has more than 200 water connections. Every outlet is equipped with a pt-100 sensor for monitoring the temperature in every cooling channel.

Normally 4-Rod RFQs have a dipole component because the upper two electrodes are on higher potential compared to the lower electrodes. The MYRRHA RFQ is the first 4-Rod RFQ with full dipole compensation. The new compensation method uses the alternate widening of the stems [6].

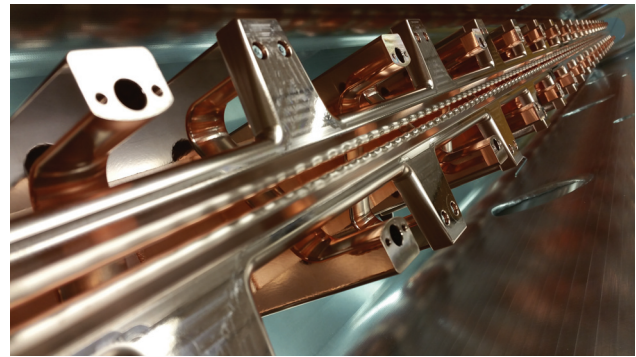

Figure 4: View along the electrodes.

CONSTRUCTION AND FIRST MEASUREMENTS

The construction of the RFQ has started End of 2015 at NTG (Gelnhausen, Germany). The vacuum tank consists of aluminum with 5 cm wall thickness milled from a solid piece. Because there are only very small losses on the tank surface (less than 1%) no copper plating were necessary. Cooling of the tank is not required because of the good heat conductivity of aluminum. Before thick copper plating of all copper parts cooling channels have been milled and filled with a special wax. After copper plating the wax has been removed. The RFQ electrodes have been fabricated in aluminum first to check the tolerances. The measured tolerances of the milling process were between 5 and 15 μ m. After assembling and alignment of all parts and the accuracy of the electrodes have been checked in every RF cell. the typical tolerance is in the order of 20 μ m which is fully within the specifications of 50 μ m. Figure 4 shows a view along the electrodes and Fig. 5 shows the fully constructed RFQ.

The tuning of the RFQ (frequency and voltage) is done by changing the height of the tuning plates which are located between the stems. After one iteration the field flatness is already about $\pm 6\%$ (s. Fig. 6). After finishing the tuning a field flatness of better than $\pm 3\%$ is expected. After assembling all auxiliary systems (vacuum, power coupler, plunger, cooling system) it is planned to test the RFQ with 12 kW cw at IAP.

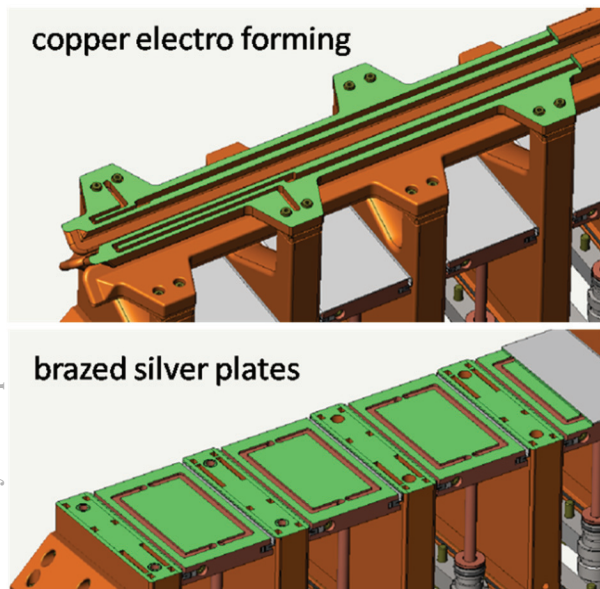

Figure 3: Optimized cooling channels of the MYRRHA RFQ.

The expected shunt impedance is 75 k Ω m. This value leads to a specific power consumption of about 26 kW/m and 103 kW in total. A major concern was the cooling of the



Figure 5: The MYRRHA-RFQ and water connections for stems and electrodes (small picture).

After this test the RFQ will be shipped to UCL (Louvain-La-Neuve, Belgium). High power RF and beam test are planned for the first half of 2018. At that time the ECR-source and the LEBT will be operational in Louvain-La-Neuve.

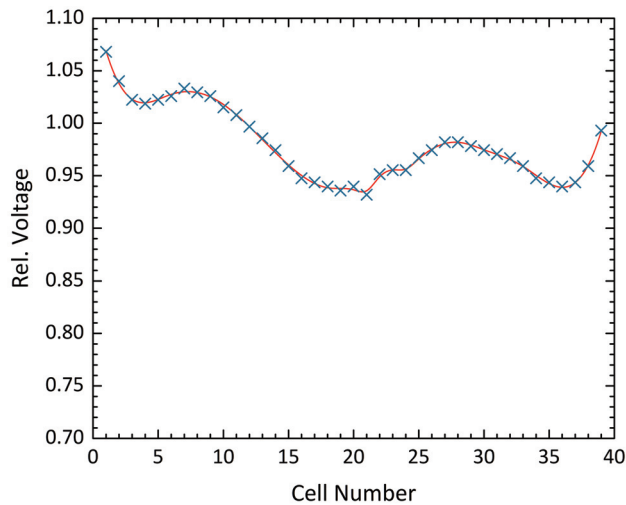

Figure 6: Field flatness after first tuning iteration.

SUMMARY

The MYRRHA project requires an extremely reliable high power proton linac. One crucial component is the RFQ. A 4-Rod RFQ has been designed with respect to beam dynamics, RF properties and excellent cooling capabilities. The

4 m long, 176 MHz RFQ accelerates protons to 1.5 MeV. The beam dynamics design emphasis on very small longitudinal emittance. For higher reliability a moderate electrode voltage of 44 kV has been chosen. An RF power of 103 kW is necessary with an assumed shunt impedance of 75 kΩm. All cooling channels have been optimized. A prototype cavity has been tested successfully with power levels of about 120 kW/m. The MYRRHA RFQ has been constructed and first field measurements have started. After the tuning process the RFQ will be tested with 12 kW cw at IAP. End of 2017 the shipment to Louvain-La-Neuve (Belgium) is planned for high power and beam tests.

REFERENCES

- [1] D. Vandeplassche *et al.*, “The MYRRHA Linear Accelerator” in *Proc. IPAC 2011*, pp. 2718–2720.
- [2] D. Mäder *et al.*, “R&D of the 17 MeV MYRRHA Injector” in *Proc. LINAC 2014*, pp. 202–204.
- [3] K. Kümpel *et al.*, “The New Injector Design for MYRRHA” in *Proc. IPAC 2017*, paper TUPVA068.
- [4] C. Zhang *et al.*, *Nucl. Instrum. Methods Phys. Res., Section A*, 586 (2008) 153-159.
- [5] C. Zhang *et al.*, “New Reference Design of the European ADS RFQ Accelerator for MYRRHA” in *Proc. IPAC 2014*, pp. 3223–3225.
- [6] K. Kümpel *et al.*, “Dipole Compensation of the 176 MHz MYRRHA RFQ” in *Proc. IPAC 2017*, paper TUPVA070.