

POWER CONVERTERS FOR THE ESS WARM MAGNETS

R. Visintini[†], M. Cautero, Elettra Sincrotrone Trieste, Trieste, Italy
G. Göransson, C. Martins, P. Torri, ESS, Lund, Sweden

Abstract

In the framework of the Italian In-Kind Contribution (IKC) to the construction of the European Spallation Source (ESS), Elettra Sincrotrone Trieste is in charge of providing some key equipment for the accelerator. Among them, there are the magnets and the associated power converters for the Linac Warm Units (LWU), the High Energy Beam Transport (HEBT) dogleg, the Dump Line (DmpL) and the Accelerator to Target (A2T) sections of the neutron source. Magnets and their power converters are complementary parts of common systems. Their design cannot be totally separated, requiring iterations for an optimal solution that should include also power cable standardization. This work will describe the power converters' solutions adopted for the magnets of the above-mentioned sections. They comprise 4-Quadrant power converters for the correctors, compact DC power converters for the small quadrupole magnets and more powerful DC power converters for the dipole and large quadrupole magnets.

INTRODUCTION: ESS

“The European Spallation Source (ESS) is a European Research Infrastructure Consortium (ERIC), a multi-disciplinary research facility based on the world’s most powerful neutron source. The unique capabilities of this new facility will both greatly exceed and complement those of today’s leading neutron sources, enabling new opportunities for researchers across the spectrum of scientific discovery, including life sciences, energy, environmental technology, cultural heritage and fundamental physics.” [1].

The neutron source is currently under construction in Lund, Sweden, in the framework of a 14-countries In-Kind Contribution (IKC) agreement [2, 3] (Fig. 1).



Figure 1: Aerial photo of ESS.

Italy is one of the founding Countries of ESS ERIC. The Italian participation to ESS consists in the In-Kind Contribution for the construction of the Facility. Three Italian Entities are involved: INFN, Elettra and CNR. Elettra, in particular, will provide components for the linear accelerator and proton beam transport.

MAGNETS AND POWER CONVERTERS

Besides superconducting accelerating sections, the accelerator requires a significant number of warm magnets – quadrupole (Qx), dipoles (D1) and combined H+V corrector magnets (Cy) – along the proton Linac (the so-called Linac Warm Units – LWUs) and beam transport [4]. Part of the Elettra contribution consists in these magnets and the associated power converters (PC).

Figure 2 reports a schematic view of the accelerator and transport line structure. In the boxes, there are the magnet types and their number.

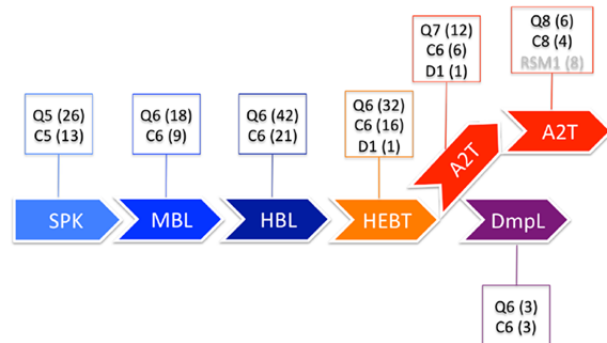

Figure 2: ESS structure with magnet types.

Table 1 summarises the type and number of warm magnets, their nominal current, and the number of power converters (PC). The acronym TBD indicates that the nominal currents are still to be defined while TBC means that the nominal current is an input parameter in the design of the corrector C8 and has to be confirmed.

Table 1: LWUs and Beam Transport Magnets and PC

Magnet Type	Magnet #	Imag [A]	PC #
Q5	26	150	26
Q6	95	180	95
Q7	12	180	12
Q8	6	TBD	6
D1	2	TBD	1
C5, C6	68	±16 A	136
C8	4	±16 A/TBC	8

In our vision, a magnet and its associated power converter are two parts of a unique system designed and optimized as a whole, considering also their installation in

[†]roberto.visintini@elettra.eu

the accelerator’s complex. Figure 3 shows the design of quadrupole magnet type Q7, comprising the protections of the connections from accidental contacts on the side and the front of the magnet. Figure 4 is the CAD rendering of type C6, combined H+V corrector magnet.

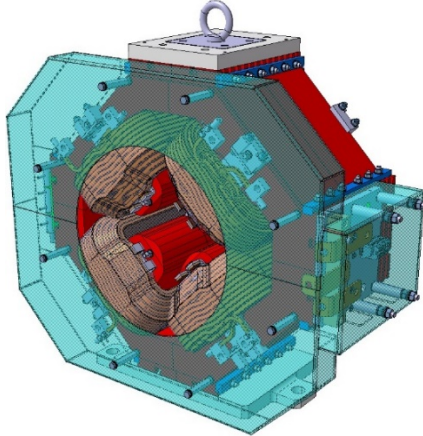

Figure 3: Q7 quadrupole with contacts covers (Courtesy D. Castronovo, Elettra).

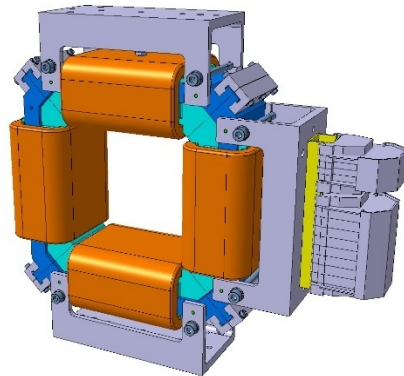

Figure 4: C6 H+V combined corrector (Courtesy D. Castronovo, Elettra).

Quadrupole Power Converters

In a previous design phase, the quadrupoles Q5, Q6, and Q7 were air-cooled ones, operated in pulsed mode [5]. We had realised a prototype pulsed power converter (described in [4]) and positively tested on an *ad-hoc* built magnet. This solution was abandoned due to the effects of the pulsed currents on the already adopted vacuum chamber of the Linac: all quadrupole magnets reported in Table 1 (including Q8, whose design is currently ongoing) are now water-cooled and will operate in DC mode.

Table 2 summarises the quadrupole power converters; the six units for the Q8 magnets are still undefined.

Table 2: LWUs and Beam Transport Quadrupole PCs

PC Type	PC #	Output Current/Voltage	Stability [ppm]
PCQ5	26	200 A / 30 V	±50
PCQ6	95	200 A / 30 V	±50
PCQ7	12	200 A / 30 V	±50
PCQ8	6	TBD	TBD

Due to the relatively low power, the power converters can be air-cooled and compact (within 4 U), allowing installation of more units in a standard 19” rack.

Notwithstanding some slight differences among Q5, Q6, and Q7 our goal is standardizing the power converters, using one type only. This will be also a prescription for the design of magnet type Q8.

Corrector Power Converters

Each combined H+V corrector magnet requires two separate and independent bipolar power converters. There are 136 units in total for the C5 and C6 magnets (see Table 3), whose characteristics are completely defined. Again, as in the quadrupole case, our goal is to have one type of PC only, and this is a firm parameter for the design of magnet C8.

Table 3: LWUs and Beam Transport Correctors’ PC

PC Type	PC #	Output Current/Voltage	Stability [ppm]
PCC5	26	±16 A/±20 V	±50
PCC6	110	±16 A/±20 V	±50
PCC8	8	TBC	TBC

The power converters we are going to use for the correctors are an Elettra in-house design, named A2720 [6], derived from a previous realization for FERMI light source [7, 8]. A standard 19”, 3-U sub-rack can host up to four independent units. Table 4 summarizes the main features, and Fig. 5 shows an A2720 unit.

Table 4: A2720 Main Characteristics

Parameter	Value	Unit
Topology	4-Quadrant	
Input Voltage	24	VDC
Nom Out. Curr.	±16	A
Max Out. Volt.	±22	V
Switching Freq.	100	kHz
Bandwidth (res. Load)	10	kHz
Out. Curr. Stability (24 h)	<25	ppm
Efficiency (16 A, 20 V)	>90	%
Curr. Resolution	40	µA

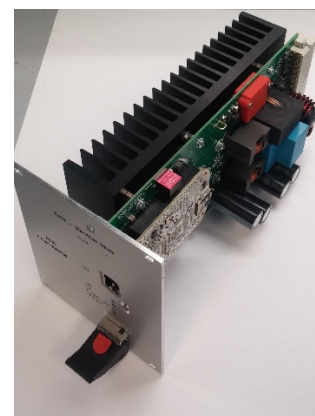

Figure 5: A2720 bipolar power converter (±16 A/±22 V).

The large heatsink allows the operation of four A2720 units in a 3U, 19" subrack, in nominal conditions, using natural air convection. Avoiding fans for cooling improves the overall system reliability.

The A2720 system comprises one 24 VDC "Bulk" power supply per unit (channel) and two (for redundancy) 12 VDC power supply for the electronics per sub-rack.

Dipole Power Converter

At the time of this paper, the dipole magnets are still in the design phase and, therefore, the associated power converter is not yet defined. There will be one power converter for the two magnets in series.

Common features among PC types

Some features are common to all power converters:

- Ethernet interface, with TCP/IP protocol as connection to the ESS Control System.
- Adoption of the 19" standard for installation in racks.
- Adoption of forced or natural convection air cooling, avoiding as much as possible water.

RACK ALLOCATION OF PC

ESS has performed studies on the allocation of the racks filled with the accelerators' equipment in the Gallery. The current design places the power converters in standard 19", 47 U, racks, with all cable inlet and outlet from top. Quadrupole and Corrector power converters will share the same racks to optimise the cable routing to the magnets in the accelerator's tunnel.

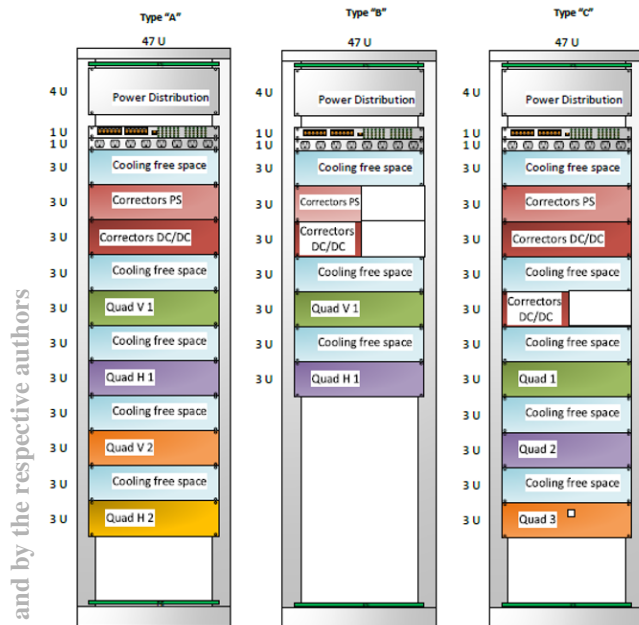

Figure 6: Proposed rack allocation of power converters (Types "A", "B", and "C").

CONCLUSION

In this paper, we have presented the updated design of the power converters for the warm magnets of the Linac

Warm Units of ESS and of the proton beam transport. There are still design activities on some magnets, and, consequently, the associated power converters cannot be defined, yet. We have presented the common aspects among the power converters, as well as the current proposal for their allocation in the equipment racks foreseen in the ESS Gallery.

ACKNOWLEDGEMENT

The authors thanks D. Castronovo (Elettra), designer and responsible for the warm magnets procurement, and Edgar Sargsyan (ESS), Magnets LWU Coordinator, for the useful interactions in the definition of the power converters.

REFERENCES

- [1] <https://europeanspallationsource.se/european-spallation-source>
- [2] H. Danared, M. Eshraqi, and M. Jensen, "The ESS Accelerator", in *Proc. 57th ICFA Advanced Beam Dynamics Workshop on High-Intensity and High-Brightness Hadron Beams (HB2016)*, Malmö, Sweden, July 2016, paper MOAM3P30, pp. 6-8.
- [3] M. Lindroos *et al.*, "ESS progressing into construction", in *Proc. 7th Int. Particle Accelerator Conf. (IPAC'16)*, Busan, Korea, May 2016, paper FRYAA02, pp. 4266-70.
- [4] R. Visintini, M. Cautero, C. Martins, G. Göransson, and M. Collins "Power Converters for the Magnets of the Linac Warm Units of ESS", in *Proc. 42nd Annual Conference of the IEEE Industrial Electronics Society (IECON'16)*, Florence, Italy, October 2016.
- [5] C. Martins, D. Castronovo, and R. Visintini, "High efficiency pulsed power converters for the ESS accelerator", presented at *Third Workshop on Energy for Sustainable Science at Research Infrastructures*, Hamburg, Germany, October 2015, parallel session IIa.
- [6] R. Visintini and M. Cautero, "A 20-Ampere, 4-quadrant power supply for magnets", in *Proc. 2nd IEEE Southern Power Electronics Conference (SPEC'16)*, Auckland, New Zealand, December 2016, paper 115.
- [7] A. Fabris, *et al.*, "FERMI upgrade plans", in *Proc. 7th Int. Particle Accelerator Conf. (IPAC'16)*, Busan, Korea, May 2016, paper MOPOW015, pp. 744-747.
- [8] R. Visintini, "FERMI magnet power supplies: design strategies and five years of operational experience", in *Proc. SPIE 2015 International Symposium on Optics + Optoelectronics*, Prague, Czech Republic, April 2015, Vol. 9512, pp. 95121P-1 - 95121P-8.