

MAGNETIC BREAKDOWNS IN SIDE-COUPLED X-BAND ACCELERATING STRUCTURES

S. Antipov, P. Avrakhov, C. Jing, S. Kuzikov
Euclid Techlabs LLC, Solon, USA

V. Dolgashev

SLAC National Accelerator Laboratory, Menlo Park, USA

Abstract

Side coupled accelerating structures are popular in the industrial realizations of linacs due to their high shunt impedance and ease of tuning. We designed and fabricated a side-coupled X-band accelerating structure that achieved 133 MOhm/m shunt impedance. This structure was fabricated out of two halves using a novel brazeless approach. The two copper halves are joined together using a stainless steel joining piece with knife edges that bite into copper. This structure had been tested at high power at SLAC National Accelerator Laboratory. The performance of the structure had been limited by magnetic breakdowns on the side-coupling cells. In this paper we will present results of the high gradient tests and after-test analysis. Scanning electron microscopy images show a typical magnetic-field induced breakdown.

INTRODUCTION

Accelerating structures designed for X-band and higher frequencies have relatively small volume. For this reason they can be fabricated in a form of split block [1] out of two halves. These two blocks can be welded or brazed together. Alternatively this design can be brazeless, when two halves are joined via viton gasket or a stainless steel joining part with knife edges, similar to conflat design [1].

Brazeless technology became of high interest to high gradient accelerator community. One argument for is that brazeless structure having not gone through thermal treatment cycle is not annealed, i.e. copper stays hard. Conditioning and breakdown studies at CLIC and SLAC show that hard copper structure can tolerate higher field gradients than annealed one. With the new brazeless split-block design high gradient applications open up for low budget prototyping.

In this paper we report on the design and testing at SLAC of a high power side coupled structure, - RBA-SLAC (relativistic brazeless accelerator).

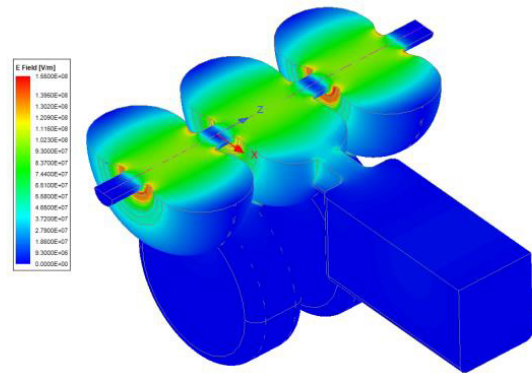

Figure 1: Microwave design simulation, electric field.

MICROWAVE DESIGN

Side-coupled accelerating structure are popular in industrial realizations due to high shunt impedance and ease of a tuning. We designed a side-coupled structure for 11.424 GHz frequency that achieved 130 MOhm/m shunt impedance. The input of 1 MW rf power establishes an accelerating gradient of 155 MV/m. The ratio of peak to accelerating electric field is 2.65 (Fig. 1). The surface magnetic field peaks at 0.85MA/m (Fig. 2) for a fillet rounding of 0.1 mm.

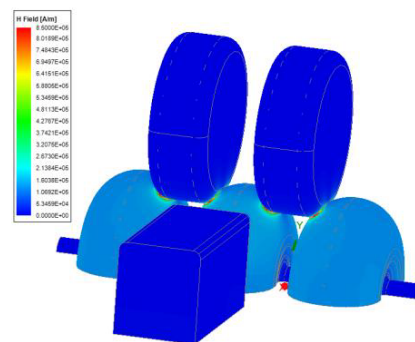

Figure 2: Microwave design simulation, magnetic field.

ENGINEERING, FABRICATION AND BENCH TEST

This structure had been fabricated out of two halves using a novel fabrication approach. The two halves of split-block are joined together by a stainless steel block with knife edges that bite into the copper (Fig. 3).

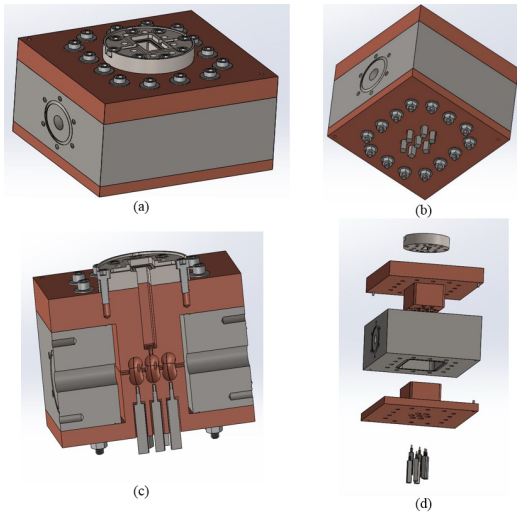

Figure 3: 3D engineering design of the RBA-SLAC structure: a) the full assembly; b) tuning pins; c) cut-away view; d) blow up view.

The structure had been produced by a high precision five-axis CNC machining (Fig. 4). The bench test of the structure (bead pull) is shown on Fig. 5.

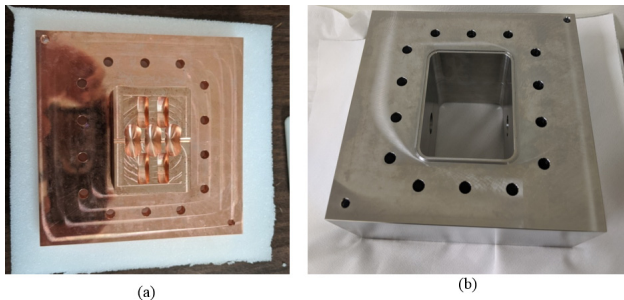

Figure 4: The finished main parts of the RBA-SLAC: a) the copper half; b) stainless steel frame.

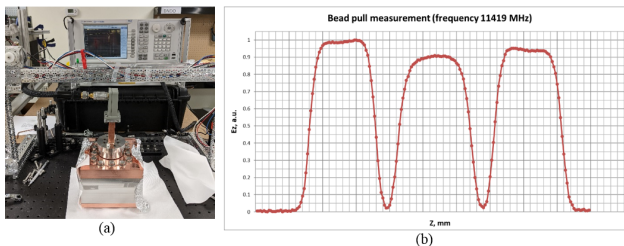

Figure 5: a) The RBA-SLAC under the bench measurement; b) the measured profile of the accelerating field on axis using the bead-pull technique.

HIGH POWER TEST AT SLAC

The high power test had been performed at SLAC early in 2021. The structure was conditioned for two weeks. Breakdown rates at different gradients had been recorded. Weak dependence on the pulse length had been observed. Base pulse length was 600 ns at 11.424 GHz. The detailed results are still being processed.

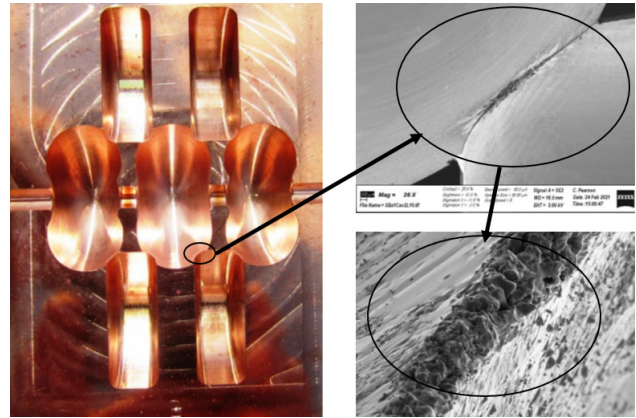

Figure 6: a) The RBA-SLAC under the bench measurement; b) the measured profile of the accelerating field on axis using the bead-pull technique.

Maximum conditioned gradient was 35 MV/m. The performance of a structure had been limited by breakdowns at the coupling cell. It turned out that the rounding at the entrance was not sufficient to reduce local magnetic field.

Post-test analysis (Fig. 6) shows typical pulsed heating erosion at the sharp edge. The side coupled cavities require special attention to the high magnetic fields. The sharp edge at the coupling cell has to be avoided.

ACKNOWLEDGEMENT

This project is supported by Small Business Innovative Research phase II grant DE-SC0017749.

REFERENCES

- [1] C. Jing, "Development of Brazeless Accelerating Cavities", presented at *International Workshop on Breakdown Science and High Gradient Technology*, Online, Apr. 2021, p. HG2021, unpublished.