

PROGRESS AND STATUS ON CIVIL CONSTRUCTION OF THE SIS100 ACCELERATOR BUILDING

M. Draisbach, J. Blaurock, M. Ossendorf, N. Pyka, P. Spiller
GSI GmbH, Darmstadt, Germany

Abstract

Besides the accelerator itself, civil construction of the accelerator ring tunnel in the northern area of the FAIR campus is a core activity of the rapidly progressing FAIR project (Fig. 1). It will facilitate and supply the future SIS100 accelerator at 17 m under ground level and has been growing continuously and according to schedule since groundbreaking in 2017. This contribution presents the current status of the civil construction progress and gives an optimistic forecast on the preparation of machine installation.

INTRODUCTION

The FAIR particle accelerator facility in Darmstadt, Germany is one of the world's biggest construction projects for international cutting-edge research. On a site of approximately 150,000 m², 25 buildings are presently being constructed. Amongst them are the underground accelerator tunnel with 1100 m circumference, for the so-called SIS100 and other unique buildings, such as the extremely complex beam transfer building. They are designed in order to house and operate the newly developed high-tech research facilities.



Figure 1: Illustration of the future FAIR facility [1].

This multinational and highly complex mega-construction project has entailed the development of integrated construction workflow planning that closely coordinates building, civil and construction engineering, accelerator development and construction, and scientific experiments [1].

CONSTRUCTION AND INSTALLATION

The construction work began in the summer of 2017. The construction site (Fig. 2) is located to the East of the present-day GSI complex, whose existing accelerators will be used as the first acceleration stage in the future. Construction phase 1 of the project includes the Northern

building site of FAIR including the facility for the superconducting SIS100 ring accelerator. It is being built by means of the cut-and-cover construction method. In this process, the construction pit “moves” - in other words, the construction takes place in sections that are about 200 meters long [1]. Just like a dog chasing its own tail excavation began with a head start at the first section, immediately followed by foundation preparation and steelwork for the building. As a result, the excavation for the complete tunnel ring hasn't even ended when the first section of the building structure was finished and filled back with soil already.



Figure 2: FAIR construction site, April 2021. View orientation: North to South [2].

Follow the link in Ref. [3] to see an 8 min video of the FAIR construction cycle, and Ref. [4] to see a 3 min drone video of FAIR construction site in April 2021.

Throughout the civil construction process the ground water level had to be lowered artificially. When construction has finished, the pumps will be stopped and the ground water will reach its natural level again. In order to protect the belowground parts of the concrete structure against the high ground water level, the complete tunnel outer surface is coated with layers of water proof material.

The completion of the FAIR campus construction activities is projected for 2027. By then,

- 2 million cubic meters of earth have to be excavated - as much as for 5,000 single-family homes;
- 600,000 cubic meters of concrete have to be used - as much as eight Frankfurt soccer stadiums;
- 65,000 tons of steel have to be utilized - as much as for nine Eiffel Towers.

Some of the building structures reach from 17 meters below ground level to 20 meters above the earth's surface and contain up to six floors. The transfer building (Fig. 3) is the most complex building of the facility. It is the central hub of the facility's beam guidance system.

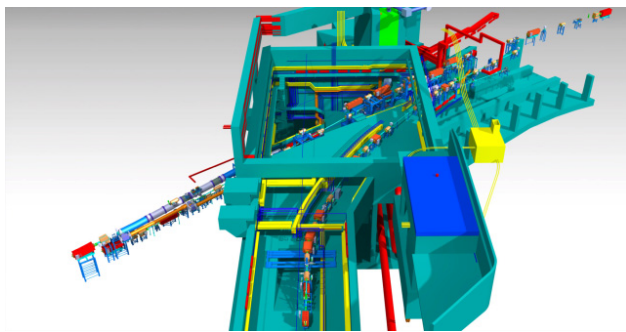

Figure 3: Section of the transfer building with several beamlines [1].

The 1100 meters long ring tunnel for the SIS100 particle accelerator will also be located 17 meters underground. A supply tunnel will be located next to the actual accelerator tunnel (Fig. 4). Here there will be room for structures such as the lines for power and liquid helium, power supply units, and possible devices for controlling the quality of the ion beam.

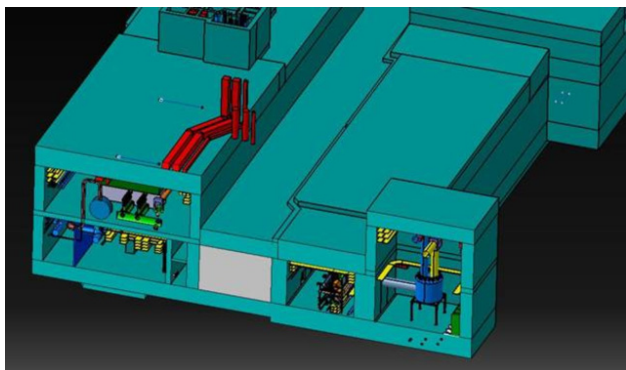

Figure 4: Cross section of the ring tunnel facility for the SIS100 accelerator. Inside of the left rectangular tunnel the accelerator is located. In the right part of the tunnel the supply facilities are placed [1].

In parallel to the concrete pouring activities in the excavation pit, all involved parties of technical building equipment engineering and accelerator physics are working together to coordinate the various aspects of installation. The vast amount of technical equipment for both building related infrastructure and accelerator physics has to be checked for collisions on a regular base to balance out the available installation space and to trouble shoot possible collisions between the involved technical parties like accelerator components, cable trays, air ducts, piping, electrical, sprinkler, helium distribution systems, etc. by help of 3D computer models.

The necessary infrastructure and the given transportation constraints of the huge accelerator parts require a tunnel cross section of 6.5 m × 4.5 m at the outer circle of the tunnel building to accommodate the actual accelerator parts including the cryogenic supply system for the superconducting magnets. In parallel to this outer “machine” tunnel the building facilitates an inner supply area of approx.

12.000 m² to accommodate all the power-, measuring- and controls equipment necessary to run the accelerator [5]. This area is roughly subdivided into

- 75 % accelerator equipment;
- 15 % building infrastructure;
- 10 % storage and transportation arranged in parallel to the outer machine tunnel.

Each machine section is powered and controlled by the corresponding supply section which ideally but not always is located in parallel to the accelerator. In order to protect people and equipment from radiation, machine tunnel and supply tunnel are divided by 9.7 m of massive concrete. No electronic device could bear up against the expected radiation at the accelerators design point. Therefore, and in order to reduce cable length, the unique parallel tunnel approach was chosen at the very beginning of the project.

Related to supplying infrastructure, we are counting as of today

- > 500 water cooled accelerator components;
- > 1.900 heat radiating accelerator components;
- > 2.100 electrical connections of accelerator components to power grid;
- > 20.000 electrical interconnections between accelerator components for SIS100 specific needs.

The main cooling water and power infrastructure is sufficiently rated to supply future expansions, including a possible SIS300 accelerator installed on top of the SIS100 accelerator in the very same building.

OUTLOOK

Despite pandemic setback, tunnel closing and completion of backfill of the SIS100 accelerator building is expected by Q4/2021. Also in late 2021, first structural systems for technical building equipment and piping are expected to start installation activities in the accelerator tunnel. With cable trays in place, we are looking at Q3/2022 for installation start of accelerator specific power cables. Assuming all of that working out according to plan, we carefully expect to move in the first pieces of accelerator equipment in late 2022.

REFERENCES

- [1] The FAIR mega-construction project, https://www.gsi.de/en/researchaccelerators/fair/fair_civil_construction/the_fair_mega_construction_project
- [2] Photos and videos of the FAIR construction site, https://www.gsi.de/en/researchaccelerators/fair/fair_civil_construction/photos_and_videos
- [3] FAIR - Construction of the particle accelerator facility, <https://www.youtube.com/watch?v=gChZDR7hdoM>
- [4] FAIR Accelerator Facility - Construction April 2021, <https://www.youtube.com/watch?v=cjmUyp0My38>
- [5] W. C. Omet *et al.*, “SIS100 Tunnel Design and Status”, in *Proc. IPAC'17*, Copenhagen, Denmark, May 2017, pp. 3316-3319. doi:10.18429/JACoW-IPAC2017-WEPVA029