

# LLRF UPGRADE AT THE ARGONNE WAKEFIELD ACCELERATOR TEST FACILITY\*

W. Liu<sup>†</sup>, C. Whiteford, E. E. Wisniewski, G. Ha, J. H. Shao, J. G. Power, P. Piot, D. S. Doran  
High Energy Physics Division, Argonne National Lab  
C. Serrano, D. Filippetto, D. Li, L. Doolittle, S. Paiagua, V. K. Vytla  
Lawrence Berkeley National Laboratory

## Abstract

The Argonne Wakefiled Accelerator (AWA) Test Facility designed and operated a homemade LLRF system for the last 20 years. It is based on NI-PXI products that has now become obsolete. The AWA's LLRF cannot keep up with the increasing stability demands of AWA's upgraded facility. An overhaul of the system is strongly desired. With the support from DOE-HEP, the AWA is collaborating with Lawrence Berkeley National Laboratory (LBNL) to upgrade its LLRF system with modern instrumentation to meet the growing stability demands. An overview of AWA's current LLRF system performance is presented together with the upgrade plan and expectations.

## INTRODUCTION

The Argonne Wakefiled Accelerator (AWA) Test Facility designed and operated a homemade LLRF system for the last 20 years. As showing in Fig. 1, the LLRF system of AWA is mainly consist of commercial hardware from National Instrument [1]: one PXI crate, NI PXI-1042, with four signal generator, NI PXI-5404, and one digitizer, NI PXI5105. This LLRF system works fine except that the hardware is becoming obsolete and it may not keep up with the increasing stability demands of AWA's upgraded facility. So an overhaul of the system is strongly desired.

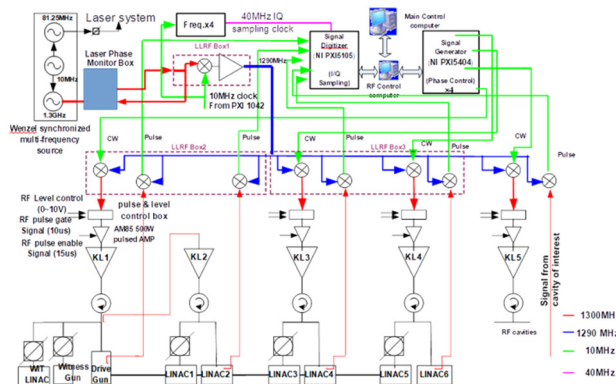

Figure 1: The Layout of AWA RF system.

## AWA LLRF SYSTEM

As showing in Fig. 1, AWA RF system has 5 RF stations, 4 of them can operate independently, except for station #2. RF station #2 is powered by a very old Litton klystron

\* Work supported by the US Department of Energy, Office of Science  
<sup>†</sup> wmliu@anl.gov

which requires about 5 kW driving power and thus it is driven by the tapping into klystron #1 output. All other klystrons are driven by a 500 W LLRF amplifier. For monitoring purpose, the klystron RF output has been picked up with directional couplers on waveguide or field pickup probes in RF cavities. All pick up signals were sent back to LLRF system for phase and magnitude measurement. The phase of high-power RF is controlled by controlling the phase of IF signal generated by NI PXI-5404. We typically operate the klystrons in saturation mode and thus we don't feedback control the magnitude of the high-power RF.

## LO Signal

The current AWA RF system has an LO frequency of 1290 MHz. This signal is generated by a 10 MHz reference signal with a 1300 MHz reference signal. The 10 MHz reference signal used to be coming from a synchronized multi-frequency source made by Wenzel [2]. It has 3 synchronized signal outputs, the 81.25 MHz for laser oscillator reference, 1300 MHz for LLRF reference and 10 MHz for LLRF reference. But analysis has shown that to the 1<sup>st</sup> order effect, the phase relation between the 10 MHz reference and 1300 MHz reference has no effect on the 1300 MHz LLRF signal and thus the 10 MHz clock signal from the PXI-1042 crate is used to simplify the connections as it is independently buffered and used to drive each peripheral slots of this PXI crate. The block diagram of the LO signal generator box is given in Fig. 2.

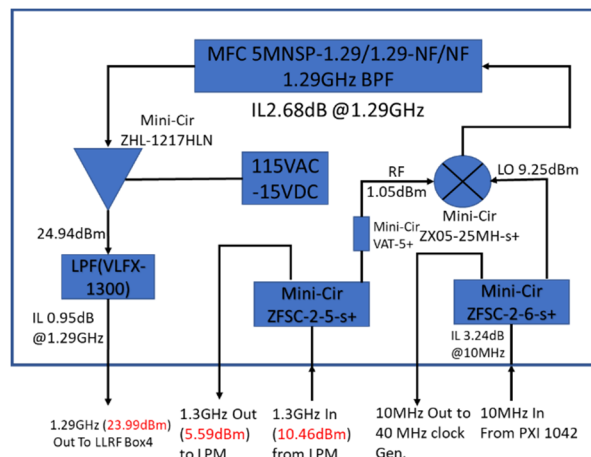

Figure 2: Block diagram of 1290MHz LO generator.

This 1290 MHz LO signal is buffered/fanned to multiple homemade transceiver/receiver boxes where the IF signals from PXI5404 up converted to 1300 MHz LLRF signals

Content from this work may be used under the terms of the CC BY 3.0 licence (© 2021). Any distribution of this work must maintain attribution to the author(s), title of the work, publisher, and DOI

and pulsed RF pickup signals are down converted into 10 MHz pulsed IF signal for measurement.

### Transceiver/Receiver Boxes

The transceiver circuit takes the phase controlled 10 MHz IF generated by PXI5404, typically at 10 dBm level, and mixed it with the buffered 12900 MHz LO signal, typically at 14 dBm level. The signal will then pass through a 1.3 GHz high Q band pass filter and then a 1.3 GHz low pass filter before sending out to gate and level control box where the signal is gated and level controlled to properly drive the 500 W pulsed LLRF amplifiers.

The receiver circuit takes the attenuated pickup signals from directional waveguide couplers or field probe in RF cavities and down convert them to 10 Hz IF. The 10 MHz IF signals are then IQ sampled by PXI-5105. The 40 MHz sampling clock is generated by frequency doubling from 10 MHz reference signal.

## LASER TO RF SYNCHRONIZATION

The laser to RF synchronization is accomplished by synchronizing the 81.25 MHz laser reference signal and the 1300 MHz LLRF reference signal. The phase relation between the laser and RF are monitored with a laser phase monitor.

As showing in Fig. 3, the laser phase monitor takes the laser photo diode signal from the laser oscillator and use high Q 1.3 GHz band pass filter to obtain a 1.3 GHz RF signal from the 81.25 MHz laser oscillator. The laser to RF phase is measured by comparing the 1.3 GHz RF signal from laser oscillator and the 1.3 GHz LLRF reference signal. To change the laser to RF phase relation, we could either change the phase of IF signals or change the delay of the 81.25 MHz reference signal.

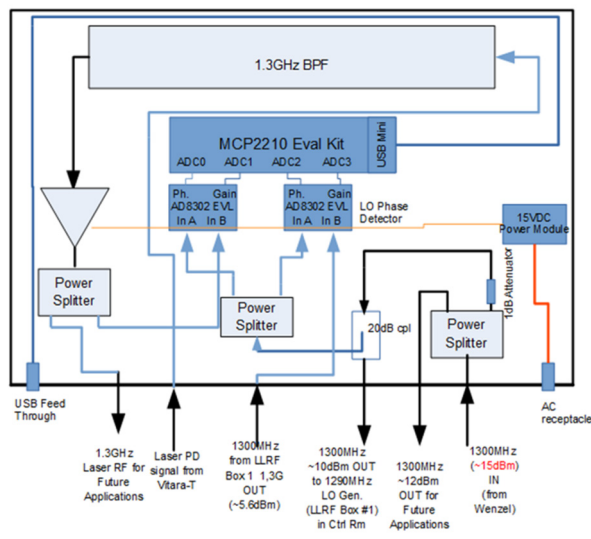

Figure 3: The block diagram of laser phase monitor.

## THE BEAM STABILITY

The existing LLRF system seems to be fine based on the measurements done with LLRF monitoring system. But we

are experiencing beam instability issue as showing in Fig. 4.

As showing in Fig. 4, the orange dots are FWHM beam spot size in x direction and the blue dots are the beam centroid in x direction. Both spot size and position are jittering while there is also a periodical swinging of beam spot size. It is clearly indicating that there is a laser to RF phase instability issue. The problem could be within LLRF, High-power RF distribution, laser to RF synchronization.

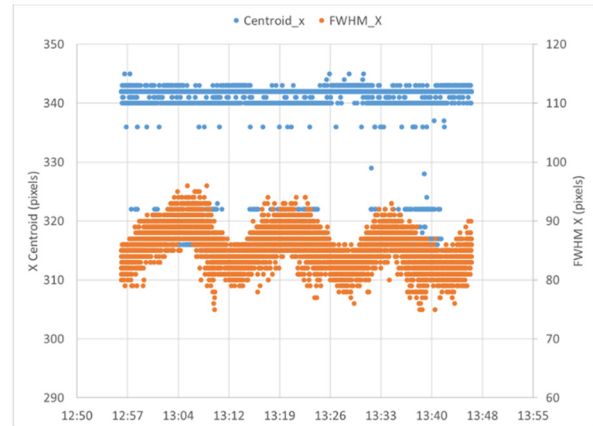

Figure 4: Electron beam spot size and position jitter on YAG screen.

## THE UPGRADE

The beam instability is a collective result of LLRF system, laser to LLRF synchronization and high-power RF distribution system. Since AWA is a small group and doesn't have the deep expertise, with the support from DOE-HEP, we are collaborating with experts from LBNL to leverage off both engineering and physics experience at LBNL in designing controls and beam measurements for LCLS-II, HiRES, PIP-II and ALS-U LLRF system.

A solid three phase plan has been developed through the collaboration and it is going on smoothly.

The LLRF upgrade will happen in the context of a larger effort, including a control system upgrade to EPICS and high-power RF upgrade. Hopefully the beam stability of AWA facility will be improved after all these upgrades.

## SUMMARY

AWA LLRF hardware is becoming obsolete while the demanding for the beam stability of AWA facility has increased as the facility grows. An overhaul of the system is strongly desired. With the support from DOE office of Science, AWA is collaborating with experts from LBNL to bringing in the state of art LLRF instrumentation and technologies by leveraging off their expertise in both engineering and physics.

## REFERENCES

- [1] National Instrument, <https://www.ni.com/en-us.html>
- [2] Wenzel Association, <https://wenzel.com>