

# OPTIMIZATION OF TWO-CELL CAVITIES FOR THE W AND H WORKING POINTS OF THE FCC-ee CONSIDERING HIGHER-ORDER MODE EFFECTS

S. Udongwo\*, S. Gorgi Zadeh†, U. van Rienen, University of Rostock, Rostock, Germany  
R. Calaga, CERN, Geneva, Switzerland

## Abstract

The lepton collider of the future circular collider (FCC-ee) aims at conducting precision measurements on the Z, W, and H bosons and the top quark. The present RF baseline considers single-cell cavities at 400 MHz for the high current Z-pole working point, four-cell 400 MHz cavities for the W and H working points, and a hybrid RF system composed of four-cell 400 MHz and five-cell 800 MHz cavities for the high energy  $\bar{t}t$  working point. A detailed study of the W working point has shown strong higher-order mode (HOM) effects in the four-cell cavities. These effects can limit the operation of the cavities in terms of HOM power and beam stability requirements. In this work, a two-cell cavity is designed as an alternative scenario for the current W- and H-RF setups. To mitigate the strong HOM effects, special attention is paid to according figures of merit when optimizing the cavity.

## INTRODUCTION

The FCC-ee aims to operate at four working points with different RF voltages and beam currents. The current baseline considers four-cell Nb/Cu 400 MHz cavities for the W and H working points. A detailed study of the W working point has shown strong HOM effects in the four-cell cavities [1]. The high beam current of 147 mA generates a high HOM power and transversal impedance, close to the beam stability threshold, in the four-cell cavities. In [2], the possibility of using a two-cell cavity for W and H working points is compared with a four-cell cavity from the RF system point of view. This paper presents some preliminary results on the design of a two-cell 400 MHz cavity as a possible alternative to the proposed four-cell cavity baseline for the W and H working points. In the design of the two-cell cavity, special attention is given to the HOMs as well as to the fundamental mode (FM) aspects of the cavity. For this purpose, a multi-objective optimization problem is formulated that takes some FM and HOM figures of merit of the cavity into account. Several geometries are then proposed, and compared with the four-cell cavity design.

## SRF CAVITY DESIGN

The performance of an accelerator cavity can be quantified by many different figures of merit such as the peak electric and magnetic fields on the surface of the cavity normalized

to the accelerating gradient, i.e.  $E_{pk}/E_{acc}$  and  $B_{pk}/E_{acc}$ , geometric shunt impedance  $R_{sh}/Q$ , longitudinal loss factor  $k_{||}$ , transversal kick factor  $k_{\perp}$ , etc. The shape of the accelerating cavity determines many of these figures of merit.

The shape of an elliptical accelerating cavity can be uniquely described by seven geometric variables  $A, B, a, b, R_i, L$  and  $R_{eq}$ , as shown in Fig. 1. Due to the strong influence of the  $R_{eq}$  on the FM frequency, this parameter is typically used for the tuning of the frequency to the desired value. For high acceleration purposes, the cavities are usually optimized to minimize  $E_{pk}/E_{acc}$  and  $B_{pk}/E_{acc}$  for the FM [3]. Low surface peak fields allow for increasing the accelerating gradient in the cavity without reaching the surface field limits.

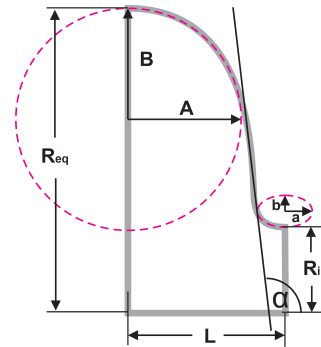

Figure 1: Geometric parameters of a half-cell elliptical cavity.

In high-current accelerators, on the other hand, the HOM effects should be considered during the design of the cavity. In order to consider both the FM and the HOM effects in the design procedure, the following optimization problem is formulated

$$\begin{aligned} \min_{R_i, L, A, B, a, b} \quad & (F_{FM}, F_{HOM}) \\ \text{subject to} \quad & f_{FM}(R_{eq}) = 400.79 \text{ MHz}, \end{aligned} \quad (1)$$

where  $F_{FM}$  takes the FM, and  $F_{HOM}$  the HOM figures of merit of the cavity into account.  $R_{eq}$  is used to tune the FM frequency ( $f_{FM}$ ). The selection of each objective function depends upon the goals of the project. The FM and HOM objective functions each include a weighted exponential sum of some figures of merit written as [4]

$$F = \left( \sum_i^m (w_i f_{i,n})^p \right)^{\frac{1}{p}}, \quad (2)$$

where  $w_i, i = 1, \dots, m$  represent the weights in case of  $m$  figures of merits  $f_i$ ,  $p$  represents the order of the chosen

\* Supported by CERN  
† Supported by BMBF

norm, and the subscript  $n$  is used to signify that the individual objective functions are normalized. All weights are set to 1, and just the 1-norm is considered in this paper. The FM objective function is defined as

$$F_{\text{FM}} = \frac{E_{\text{pk}}/E_{\text{acc}}}{2.2} + \frac{B_{\text{pk}}/E_{\text{acc}}}{5.0 \frac{\text{mT}}{\text{MV/m}}}, \quad (3)$$

where 2.2 and 5.0 mT/(MV/m) are used to normalize  $E_{\text{pk}}/E_{\text{acc}}$  and  $B_{\text{pk}}/E_{\text{acc}}$ , respectively.

Some dangerous HOMs that can be trapped in the cavity are considered in the definition of HOM objective function as follows

$$F_{\text{HOM}} = \frac{\text{Max}(\Re(Z_L))_{(f>450\text{MHz})}}{0.3 \text{ k}\Omega} + \frac{\text{Max}(|Z_T|)_{(f>650\text{MHz})}}{3 \text{ k}\Omega/\text{m}}. \quad (4)$$

In the first term, the maximum of the real part of the longitudinal impedance  $Z_L$  above the FM frequency is considered and normalized to 0.3 k $\Omega$ , considering a wavelength of 50 m. The impedance is calculated up to four times the FM frequency, i.e. 2.0 GHz. The second term considers the maximum value of the transversal impedance  $Z_T$  above 650 MHz. Since the  $\text{TE}_{111}$  and  $\text{TM}_{110}$  modes are typically trapped in the cavity and need specially designed HOM couplers for damping, the focus is given to the other high transversal impedance peaks to decrease the restrictions on designing the HOM couplers. The normalization values give an acceptable value for each objective function and are chosen based on some prior studies.

## OPTIMIZATION METHOD

To reduce the search space for our preliminary study, the ellipses on the equator and the iris of the cavity were assumed to have a circular shape, i.e.  $A = B$  and  $a = b$ . This assumption was based on the fact that parameters  $B$  and  $b$  have a small impact on the chosen objective functions. This assumption reduces the free parameters from six to four. A parameter sweep in 4D was carried out considering  $A \in [50, 110]$ ,  $a \in [20, 70]$ ,  $L \in [160, 190]$ , and  $R_i \in [150, 160]$ , where all dimensions are in mm. Large values for  $R_i$  are considered to search only among the shapes that have relatively low HOM loss factor. For each geometric configuration, first, an eigenmode simulation was carried out with SLANS [5], and an optimum  $R_{\text{eq}}$  was determined by solving a 1D optimization problem to tune the frequency. The FM figures of merit, such as the values of  $E_{\text{pk}}/E_{\text{acc}}$  and  $B_{\text{pk}}/E_{\text{acc}}$  for the tuned cavity were stored. In the next step, ABCI code [6], which is a 2D axisymmetric wakefield solver, was used to calculate the longitudinal and transversal impedance of the tuned cavity (using the optimized  $R_{\text{eq}}$ ).

## RESULTS

Figure 2 shows the two objective functions of Eq. (1) plotted with respect to each other. The Pareto optimal points, which are optimal in the sense that no objective function could be improved without making the other objective function worse, are highlighted in blue. Three geometries are

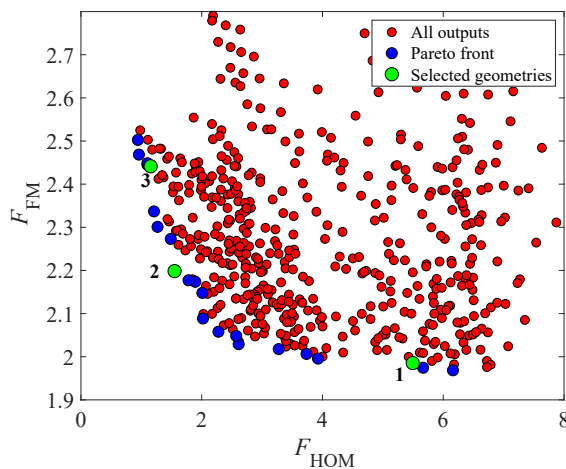

Figure 2: A Pareto distribution of the two objective functions. The Pareto front is highlighted by blue markers.

selected from the Pareto front. Geometry 1 ( $C_1$ ) favors more  $F_{\text{FM}}$ , Geometry 3 ( $C_3$ ) favors  $F_{\text{HOM}}$ , and Geometry 2 ( $C_2$ ) is an intermediate sample. The shapes of the selected cavities are shown in Fig. 3, and a summary of the figures of merit and the geometrical parameters of the selected cavities are shown in Tables 1 and 2, respectively. In Table 1, a bunch length of 6 mm, the bunch length for the W working point, was used for the calculation of the loss and kick factors and  $E_{\text{acc}}$  is calculated from  $V_{\text{acc}}$  with a length of  $n_{\text{cell}} \times 374$  mm. The variables in Table 2 with the subscript e refer to the end half-cell of the four-cell cavity. All dimensions are given in mm.

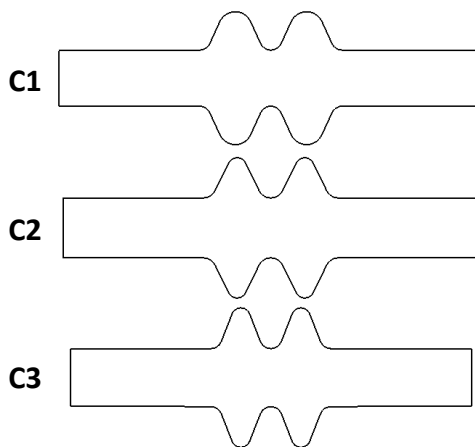

Figure 3: The shapes of the selected geometries.

The four-cell cavity is more efficient in terms of the FM figures of merit compared to the optimized two-cell cavities. This is because the middle-cells of the four-cell cavity are optimized for low surface losses with  $R_i = 120$  mm, which helps to decrease  $E_{\text{pk}}/E_{\text{acc}}$  and  $B_{\text{pk}}/E_{\text{acc}}$ . However, because of the limitations on the input power, the cavities are not planned to be operated at very large  $E_{\text{acc}}$  in the W

Table 1: Summary of Some Figures of Merit for the Selected Shapes and the Four-Cell Baseline Cavity

Parameter	$ k_{  } $ [V/pC]	$k_{\perp}$ [V/pC/m]	$f_{TE111} - f_{TM010}$ [MHz]	$R_{sh}/Q_{FM}$ [ $\Omega$ ]	$E_{pk}/E_{acc}$	$B_{pk}/E_{acc}$ [mT/(MV/m)]
$C_1$	0.3974	0.2874	66.01	165.8	2.03	5.3
$C_2$	0.3459	0.2220	60.21	147.2	2.12	6.2
$C_3$	0.3358	0.2308	80.51	144.7	2.46	6.6
$C_{baseline}$	1.078	0.8861	85.21	411.3	2.0	4.2

Table 2: Geometric Data of Selected Shapes and Baseline Four-Cell Cavity

Var	$C_1$	$C_2$	$C_3$	$C_{baseline}$
$A/A_e$	90	50	50	135.44/133
$B/B_e$	90	50	50	114.9/102
$a/a_e$	60	70	60	43.5/34
$b/b_e$	60	70	60	71.19/46
$R_i/R_{i,e}$	150	160	155	120/156
$L/L_e$	190	180	160	187/171.5
$R_{eq}$	355.042	374.924	372.642	333.182
$\alpha/\alpha_e$	114.5°	116.1°	111.3°	100°/96.9°

working point. The HOM aspects of the designed two-cell cavities outperform the four-cell cavities. Fig. 4 shows the longitudinal impedance of the selected geometries. The cavities  $C_1$  and  $C_3$  have no dangerous trapped HOM with large longitudinal impedance, while for the four-cell cavity the high impedance peaks could give rise to a significant HOM power in case of resonant excitation of such modes by the beam [1, p. 129]. The low loss factors of the two-cell cavities, compared to the four-cell cavity, can decrease the total HOM power by more than a factor two. The two-cell cavities also have fewer transversal impedance peaks, compared to the four-cell cavity as shown in Fig. 5. In addition, the damping of the trapped dipole modes is simpler in a two-cell cavity because the HOM couplers can directly couple to the field inside the cavity through the end groups, while with the conventional damping schemes there is no direct access to the field of the middle-cells of the four-cell cavity.

## CONCLUSION

In this paper, a multi-objective optimization problem was solved to design a two-cell cavity as a possible alternative to the existing four-cell cavity design for the W and H working points of the FCC-ee. The low loss factor and the low longitudinal impedance for the designed two-cell cavities significantly reduce the HOM power for the W working point, while it is in a critical range for the four-cell cavities. The damping of the trapped dipole modes with large transversal impedance is also simpler for the two-cell cavities. The price paid is in the FM figure of merit which is higher for the selected optimized two-cell cavities. The future work includes increasing the search space by assuming an elliptical shape

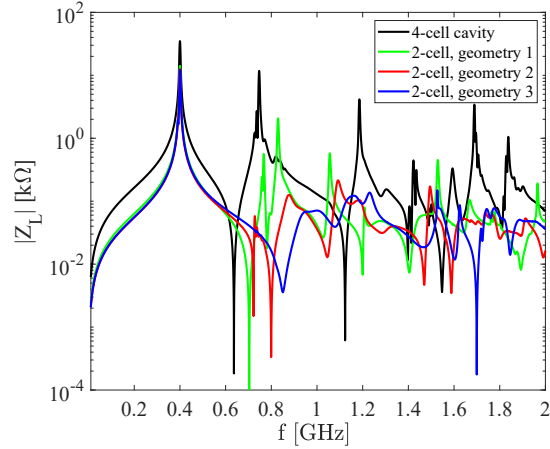

Figure 4: Longitudinal impedance of the selected cavities. The impedances are calculated from a wavelenght of 100 m for better resolution.

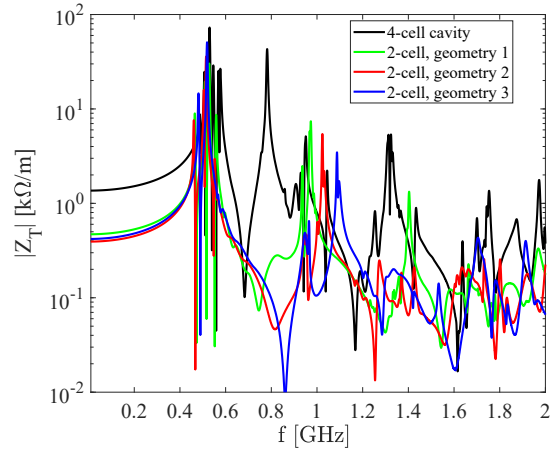

Figure 5: Transversal impedance of the selected cavities. The impedances are calculated from a wavelenght of 100 m.

for the iris and equator ellipses, i.e.  $A \neq B$  and  $a \neq b$ , with the aim to improve the FM figures of merit of the cavity.

## REFERENCES

- [1] S. G. Zadeh, "Accelerating cavity and higher-order mode coupler design for the Future Circular Collider", Ph.D. thesis, Theoretische Elektrotechnik, Universität Rostock, 2020. <http://pur1.uni-rostock.de/rosdok/id00003023>

- [2] S. G. Zadeh, U. van Rienen, R. Calaga, and F. Gerigk, “FCC-ee Hybrid RF Scheme”, in *Proc. 9th Int. Particle Accelerator Conf. (IPAC'18)*, Vancouver, Canada, Apr.-May 2018, pp. 173–175. doi:10.18429/JACoW-IPAC2018-MOPMF036
- [3] V. Shemelin, S. G. Zadeh, J. Heller, and U. van Rienen, “Systematical study on superconducting radio frequency elliptic cavity shapes applicable to future high energy accelerators and energy recovery linacs”, *Physical Review Accelerators and Beams*, vol. 19, no. 10, p. 102002, 2016. doi:10.1103/PhysRevAccelBeams.19.102002
- [4] R. T. Marler and J. S. Arora, “Survey of multi-objective optimization methods for engineering”, *Structural and multidisciplinary optimization*, vol. 26, pp. 369–395, 2004. doi:10.1007/s00158-003-0368-6
- [5] D. G. Myakishev and V. P. Yakovlev, “The New Possibilities of SuperLANS Code for Evaluation of Axisymmetric Cavities”, in *Proc. 16th Particle Accelerator Conf. (PAC'95)*, Dallas, TX, USA, May 1995, paper MPC17, pp. 2348-50. <http://epaper.kek.jp/p95/ARTICLES/MPC/MPC17.PDF>
- [6] Y. H. Chin, “User’s guide for ABCI version 8.7: Azimuthal Beam Cavity”, CERN, Geneva, Switzerland, Rep. CERN-SL-94-02-AP, Feb. 1994.