

REDESIGN OF THE JEFFERSON LAB -300 kV DC PHOTO-GUN FOR HIGH BUNCH CHARGE OPERATIONS*

S. A. K. Wijethunga[†], J. R. Delayen, G. A. Krafft¹, G. Palacios-Serrano
Old Dominion University, Norfolk, Virginia, 23529, USA

M. A. Mamun, C. Hernandez-Garcia, R. Suleiman, M. Poelker, J. Benesch
Thomas Jefferson National Accelerator Facility, Newport News, Virginia, 23606, USA

¹also at Thomas Jefferson National Accelerator Facility, Newport News, Virginia, 23606, USA

Abstract

Production of high bunch charge beams for the Electron-Ion Collider (EIC) is a challenging task. High bunch charge (a few nC) electron beam studies at Jefferson Lab using an inverted insulator DC high voltage photo-gun showed evidence of space charge limitations starting at 0.3 nC, limiting the maximum delivered bunch charge to 0.7 nC for beam at -225 kV, 75 ps (FWHM) pulse width, and 1.64 mm (rms) laser spot size. The low extracted charge is due to the modest longitudinal electric field (E_z) at the photocathode leading to beam loss at the anode and downstream beam pipe. To reach the few nC high bunch charge goal, and to correct the beam deflection exerted by the non-symmetric nature of the inverted insulator photo-gun the existing photo-gun was modified. This contribution discusses the electrostatic design of the modified photo-gun obtained using CST Studio Suite's electromagnetic field solver. Beam dynamics simulations performed using General Particle Tracer (GPT) with the resulting electrostatic field map obtained from the modified electrodes confirmed the validity of the new design.

INTRODUCTION

Delivering high bunch charge beams for the EIC cooler to meet the ion beam high luminosity specification has been a challenging task. At Jefferson Lab, we studied space charge limitations for generating electron beams using a DC high voltage photo-gun with inverted insulator geometry, biased at -225 kV, with a bialkali-antimonide photocathode and a commercial laser [1]. At -225 kV, the extracted charge at the dump was only ~ 0.3 nC. Increasing the laser power yielded ~ 0.7 nC but with significant vacuum activity in the beamline stemming from beam loss [1].

DC high voltage photo-guns have been employed in a variety of accelerator facilities to produce both polarized and non-polarized beam such as the Continuous Electron Beam Accelerator Facility (CEBAF), Free Electron Lasers (FELs), Energy Recovery Linacs (ERLs), etc. The majority of these photo-guns have a Pierce geometry at the cathode front to focus the beam [2-5]. In addition, inverted insulator geometry photo-guns like the JLab design serve to connect the high voltage cable to the cathode electrode, and have a shield to minimize the electric field at the insulator-

metal-vacuum interface known as the triple point junction [3]. However, the Pierce geometry reduces the E_z at the cathode, thus increasing space charge effects and reducing bunch charge extraction. Additionally, the inverted insulator and triple point junction shield combine to introduce asymmetric electric fields in the anode-cathode gap which then result in deflecting the beam vertically at the exit of the anode, causing difficulty in beam steering, and ultimately beam losses [2-5]. This paper presents the electrostatic design of the modified photo-gun resolving the above design issues using CST Studio Suite's electromagnetic field solver to obtain a higher E_z at the cathode while keeping the beam on-axis in comparison with the original photo-gun [6]. Further, beam simulations conducted using GPT software [7], implementing the electrostatic field map obtained from the modified electrodes will also be presented.

ORIGINAL PHOTO-GUN DESIGN

Figure 1 shows the 3D CST model of the original photo-gun design which mainly includes a 15 cm diameter spherical cathode electrode with a 25° Pierce focusing geometry. The angle terminates on a 1.2 cm diameter aperture exposing the flat photocathode. The electrically isolated anode with slightly curved front face to match to the Pierce geometry is located 9 cm downstream of the cathode front. The inverted ceramic insulator, triple point junction shield, and array of eight non-evaporable getter (NEG) pump modules complete the photo-gun assembly [2].

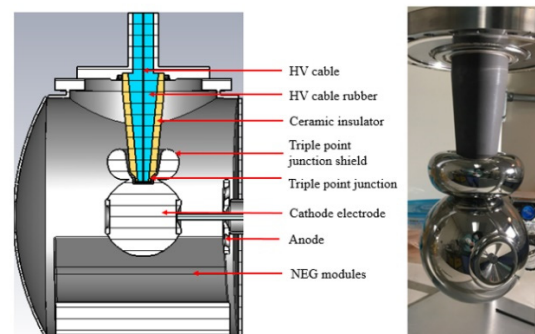

Figure 1: Left: CST model of the original gun. Right: Photograph of the cathode electrode assembly mounted to the inverted insulator. The spherical photocathode is 15 cm in diameter.

* Authored by Jefferson Science Associates, LLC under U.S. DOE Contract No. DE-AC05-06OR23177. Additional support comes from JSA initiatives fund program and Laboratory Directed Research and Development program.

[†] wwije001@odu.edu

This gun operated reliably at -300 kV high voltage and 10^{-12} Torr vacuum without field emission or high voltage breakdown.

Due to the Pierce geometry the E_z at the photocathode was 2.5 MV/m at -350 kV, which is relatively small for extracting nC bunches. Additionally, the asymmetric nature of the inverted photo-gun leads to significant beam deflection; Fig. 2 illustrates the beam trajectory obtained using GPT simulations. The left figure shows a slight beam deflection (~ 3 mm at 1 m) in x due to the asymmetry in placing NEG pumps at the bottom of the vacuum chamber. The right figure shows a significantly larger beam deflection (~ 3.3 cm at 1 m) due to the inverted insulator and triple point junction shield. Standard steering magnets placed just at the exit of the gun chamber can correct these deflections and minimize the beam loss.

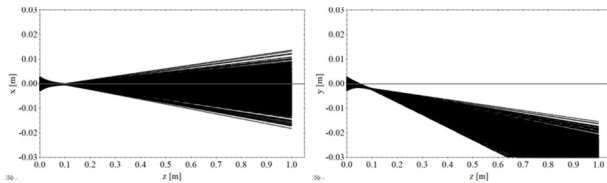

Figure 2: Beam trajectory (Left) x and (Right) y.

MODIFIED PHOTO-GUN DESIGN

The E_z at the photocathode depends on the anode-cathode gap and on the Pierce geometry. The anode-cathode gap is a trade-off between achieving sufficiently higher E_z for charge extraction but not too high to minimize the risk of field emission. Fig. 3 shows E_z variations with the anode-cathode gap from 4 cm to 9 cm without the Pierce geometry (flat cathode front and flat anode front). The cathode is placed at 0 m with applied high voltage -350 kV. According to previous experience, the field emission can be negligible (after high voltage conditioning) when the gradient is maintained below ~ 10 MV/m [3]. Hence, though the 4 cm gap gives the highest E_z at the cathode, since it approaches -10 MV/m we settled on the 5 cm gap with no Pierce geometry. It provides -7.8 MV/m E_z at the cathode.

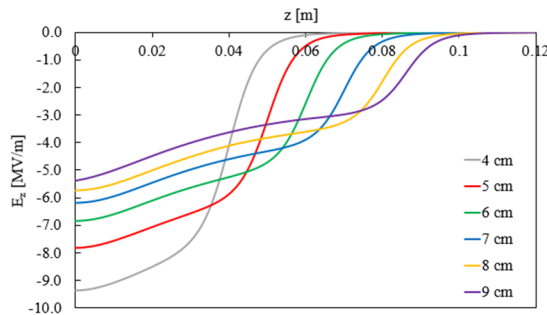

Figure 3: E_z vs z for different cathode-anode gaps.

Next, we focus on the beam deflection. The asymmetry in the x direction can be minimized by replacing the large NEG modules with NEG sheets which also helps to reduce the electric field at the bottom of the cathode electrode. The significantly large beam deflection in y cannot be removed

without risking field emission and high voltage breakdown, e.g. if we decide to remove the triple point junction shield. Instead after a thorough examination of the design we found out that it can be cancelled by lowering the anode aperture by a few mm. Fig. 4 illustrates the beam deflection variation with anode aperture shift.

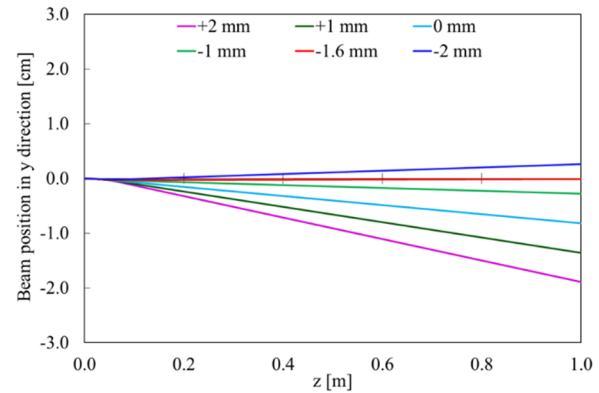

Figure 4: GPT simulations of beam deflection in y for different anode aperture shifts.

Beam deflection in y is very sensitive to the anode aperture shift. According to our simulation results the beam deflection can be completely cancelled by shifting the anode aperture 1.6 mm in the negative y direction.

Figure 5 shows the electrostatic field distribution inside the modified photo-gun at -350 kV biased cathode. The new design maintains the -10 MV/m electric field limit everywhere inside the chamber.

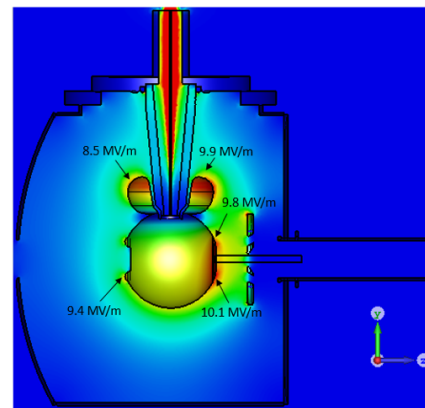

Figure 5: CST simulation results showing the electrostatic field distribution of the modified gun biased at -350 kV. The horizontal (left) and vertical (right) electric field profiles in the anode-cathode gap of the modified photo-gun design are illustrated in Fig. 6. The color map (a) shows the E_x distribution and the (b) graph shows the magnitude of E_x along each of the colored dotted lines shown on the field map. The (c) and (d) panels show the corresponding results for E_y . In both cases the vertical position of each dotted line is indicated with respect to the beam axis. According to (b) E_x is symmetric along the axis but (d) shows that E_y is distorted first due to the inverted insulator and triple point junction screening electrode and then due to the shifted anode aperture.

Content from this work may be used under the terms of the CC BY 3.0 licence (© 2021). Any distribution of this work must maintain attribution to the author(s), title of the work, publisher, and DOI

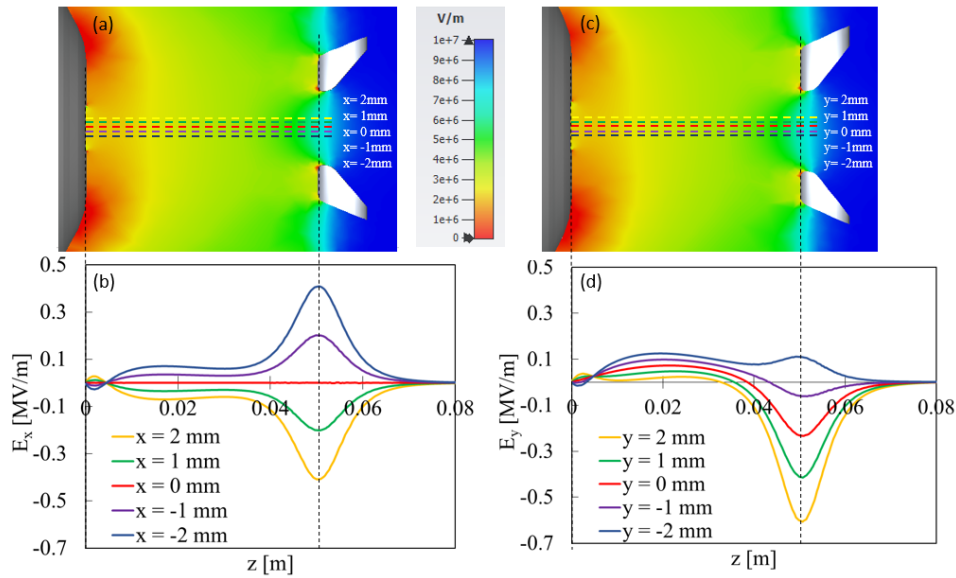

Figure 6: (a) E_x , (c) E_y variations along the dotted colored lines between the anode cathode gap when biased at -350 kV where each color line position is indicated with respect to the x axis (b) and y axis (d).

Figure 7 illustrates the GPT simulations of the beam trajectory (left) in x and (right) in y. With the shifted anode aperture, the beam is centered in both directions.

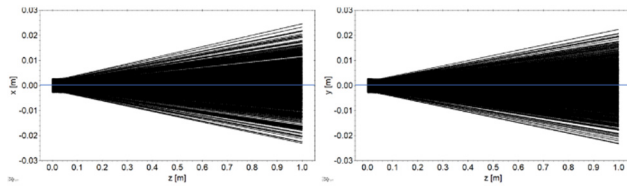

Figure 7: Beam trajectory (left) x and (right) y.

This beam deflection can also be corrected by tilting the anode and it will be discussed in comparison with the anode aperture shift in a journal publication.

Figure 8 provides charge extraction simulation results using GPT with the original and modified photo-gun electric field maps. Hence, the extracted charge at the cathode doubled with the increased E_z [1].

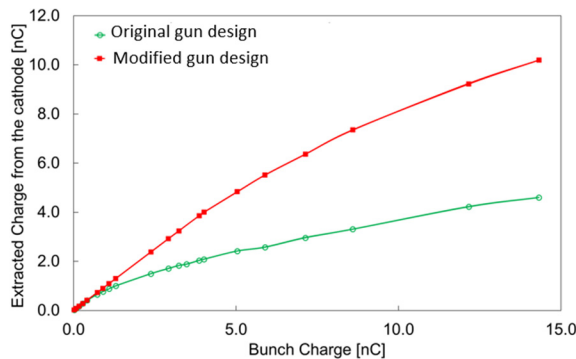

Figure 8: GPT simulations of the extracted charge at the cathode vs initial bunch charge from original and modified gun designs. (300 kV, 50 kHz, 75ps (FWHM), 1.64 mm (rms)).

CONCLUSION

Jefferson Lab's -300 kV photo-gun was re-designed using CST Studio Suite's electromagnetic field solver to obtain a higher E_z at the photocathode for high bunch charge operations and to correct beam trajectory deflections inherent to the inverted insulator geometry design. The longitudinal electric field magnitude E_z was increased from -2.5 MV/m to -7.8 MV/m by removing the Pierce geometry and decreasing the anode-cathode gap from 9 cm to 5 cm. The realization of the anode aperture shift effect on beam trajectory represents a significant advancement for photo-gun designs with inverted insulator geometry. A 1.6 mm vertical downward shift of the anode aperture is a simple design change to eliminate beam deflection. Our simulation results show that extracted bunch charge from the photocathode should increase from 4.6 nC to 10.2 nC before accounting for beam loss. Modified parts have already been built, polished and are ready for assembly and commissioning.

ACKNOWLEDGEMENT

This work is supported by the Department of Energy, under contract DE-AC05-06OR23177, JSA initiatives fund program, and the Laboratory Directed Research and Development program.

REFERENCES

- [1] S. A. K. Wijethunga *et al.*, "Space charge effect in low energy magnetized electron beam", in Proc. 12th Int. Particle Accelerator Conf. (IPAC'21), Campinas, Brazil, May 2021, paper WEPAB093, this conference.
- [2] P. Adderley *et al.*, "Load-locked dc high voltage gas photo-gun with an inverted-geometry ceramic insulator", *Phys. Rev. ST Accel. Beams*, vol. 13, p. 10101, 2010. doi:10.1103/PhysRevSTAB.13.010101

- [3] C. Hernandez-Garcia *et al.*, “Compact 300 kV DC inverted insulator photo-gun with biased anode and alkali-antimonide photocathode”, *Phy. Rev. ST Accel. Beams*, vol. 22, p. 113401, 2019. doi:10.1103/PhysRevAccelBeams.22.113401
- [4] G. Palacios-Serrano *et al.*, “Electrostatic design and conditioning of a triple point junction shield for 200 kV DC high voltage photo-gun”, *Review of scientific instruments*, vol. 89, p. 104703, 2018. doi:10.1063/1.5048700
- [5] N. Nishimori *et al.*, “Experimental investigation of an optimum configuration for a high-voltage photoemission gun for operations at > 500 kV”, *Phy. Rev. ST Accel. Beams*, vol. 17, p. 053401, 2014.
doi:10.1103/PhysRevSTAB.17.053401
- [6] CST Studio Suite’s, <http://www.cst.com>
- [7] General Particle Tracer, <http://www.pulsar.nsl/gpt>