

THE INNER TRIPLET STRING FACILITY FOR HL-LHC: DESIGN AND PLANNING

M. Bajko, S. Bertolasi, C. Bertone, S. Blanchard, D. Bozzini, O. Brüning,
P. Cruikshank, D. De Luca, N. Dos Santos, F. Dragoni, N. H. Garcia, A. Herty,
A. Kosmicki, W. Maan, A. M. Selles, P. M. Urios, S. Le Naour, P. Orlandi, A. Perin,
M. Pojer, F. R. Mateos, G. Rolando, L. Rossi, H. Thiesen, E. Todesco, E. Vergara,
D. Wollmann, S. Yammine, J. Zawilinski, M. Zerlauth
CERN, Geneva, Switzerland

Abstract

In the framework of the HL-LHC project, full-scale integration and operational tests of the superconducting magnet chain, from the inner triplet quadrupoles up to the first separation/recombination dipole, are planned in conditions as similar as possible to the final set-up in the LHC tunnel. The so-called IT String will be assembled on the surface, in CERN's SM18 Test Hall, using prototypes and first-of-series equipment. The IT String includes all of the required systems for operation at nominal conditions, such as vacuum, cryogenics, warm and cold powering equipment, and protection systems. The IT String is intended to be both an assembly, and an integration test stand, and a full rehearsal of the systems working in unison. It will, closely reproducing the mechanical, electrical, and thermo-hydraulic interfaces of the final installation, as well as allowing a full rehearsal of the systems working in unison.

This paper describes the conceptual design, the test stand's reference configuration, and the main goals. It also summarizes the status of the main activities, including the detailed design of the test infrastructure, procurement of main equipment, the baseline installation schedule, and major milestones. The first version of the experimental program and the associated planning are also presented.

THE GOAL OF THE IT STRING

In the future HL-LHC configuration, the present LHC's Inner Triplet (IT) region of the Interaction Regions IR1 and IR5 will be fully replaced. The cryo-modules will be completely different mainly due to the employment of new technology. The D1 separation dipoles will be superconducting, as opposed to those presently installed.

The IT quadrupoles of the triplet will use Nb₃Sn superconductors instead of Nb-Ti. The HL-LHC IT magnets will be powered with a higher current than the present ones. This will be achieved with a superconducting link (SC Link) based on a MgB₂ compound. Magnet protection for Nb₃Sn superconductor technology will differ greatly due to its particular characteristics at low and medium fields and the high magnetic energy stored within [1].

The main goal of the IT String is to represent, as closely as achievable in a surface building, the various operational conditions and to study and validate the collective behaviour of different equipment and systems that it consists of, before their final installation and commissioning in the LHC tunnel.

IT STRING CIRCUITS

The cryo-modules of the IT String contain several magnets either produced at CERN or in industry within the collaborations of the HL-LHC project. Table 1 summarizes the main characteristics of the IT String test stand.

Table 1: Summary of IT String Characteristics

Characteristic	Unit	Value
Number of cryo-modules	-	6
Number of magnets	-	19
Number of circuits	-	17
Number of racks		55
Length of power cables	m	800
Operating temperature	K	1.9
Max heat load dissipation	W	1250
Max stored energy	MJ	39
Max voltage to ground	kV	3
DC current rating range	kA	0.12-18

In the IT String, as in the final HL-LHC configuration, the magnets will be powered via a SC Link system composed of a MgB₂ multi-conductor cable and connected to two cryogenic feed boxes.

The first feed box (DFHX) provides the interface with the room temperature connections. It contains the High Temperature Superconductor (HTS) Current Leads (CLs). The second feed box (DFX) is the interface between the SC Link and the cryo-modules. The SC Link, the CLs and the cryogenic feed boxes compose the so-called 'cold powering' system.

On the room temperature side, the CLs are connected to the Power Converters (PCs) via normal conducting bus bars and water- or air- cooled cables. Circuit Disconnecter Boxes (CDBs) will be installed between the PC and the CLs, enabling fast and safe galvanic disconnection between the magnet circuits and the PC. Figure 1 shows the IT String circuit layout.

CRYOGENIC COOLING

As presently in the LHC, the IT String will work at a nominal operating temperature of 1.9 K, cooled with superfluid helium.

The IT String will be cooled with a dedicated cryogenic

system, composed of a valve box allowing connection to the SM18 test hall's cryogenics infrastructure, a proximity distribution system, and a transfer line (SQXL) to directly feed the cryo assemblies with superfluid He. The SC link on the magnet side will be cooled with helium gas. At the exit, the gas will be warmer, and used to thermalize the CLs. The warm He gas will then be sent back to the cryogenic infrastructure. The cryogenic system is designed to enable a test of the ultimate heat load of up to 500 W. The most demanding events for the cryogenic infrastructure will be the quenching of the quadrupole circuit, for which the estimated total energy dissipated into the He bath may be as high as 39 MJ [2].

on all quadrupole magnets in order to reduce the quench load ($\int I^2 dt$) to the circuit.

ALIGNMENT SYSTEM

An innovative full remote alignment system (FRAS) has been developed for the HL-LHC [3] and will be deployed for validation in the IT String. Micrometric monitoring and alignment of the cryo-magnets will be possible remotely through the motorized jacks during operation of the facility.

The FRAS is composed of several sub-systems. The internal system will monitor the position of the quadrupole cold masses inside the cryostat by means of 12 frequency scanning interferometry (FSI) measurement lines.

To accurately determine the positions of the cryostat with respect to each other, the system will use- 28 Wire Positioning Sensors (PS), 28 Hydrostatic Levelling Sensors (HLS), and 6 FSI sensors for the longitudinal position, together with environmental sensors - will be installed.

VACUUM SYSTEM

The overall layout of the HL-LHC insulation vacuum is different from the system currently installed in the LHC. It differs in the position and number of vacuum barriers, by-passes, and instrumentation. The IT String will validate the insulation vacuum layout configuration. However, the facility will not be equipped with a beam screen, meaning that the insulation vacuum will be common with the beam vacuum.

THE IT STRING IN THE SM18 HALL

In the past, the SM18 building had hosted the LHC String 1 [4] and String 2 [5] experiments. The HL-LHC IT String will be the third time that the hall is used to host a special test stand of this type.

The choice of location is primarily based on the readily available installations and infrastructures. A total length of 120 m is available. Both the primary and demineralized water systems have been enlarged, together with the electrical network.

The latest major upgrade concerned the cryogenic infrastructure: the production of liquid helium has been expanded from 25 g/s by additional 35 g/s, and the pumping capacity is foreseen to be increased to 18 g/s exclusively dedicated to the IT String. This configuration allows simultaneous testing of individual components for SC magnets, SC Radio Frequency Cavities, and SC link systems in the same building [6].

Due to its dimensions and complexity, the IT String will occupy a ground surface of 880 m² and it will be integrated into the SM18 test hall on two levels. The ground level hosts the cryo modules, the cryogenic-, the demineralised water-, general electrical powering- and signal- distribution equipment, alongside any control racks. On an elevated platform with limited access, the warm and cold powering with the associated EE and CDBs will be installed. This configuration allows to easily cordon off a well-defined zone, instead of having to vacate the entire IT

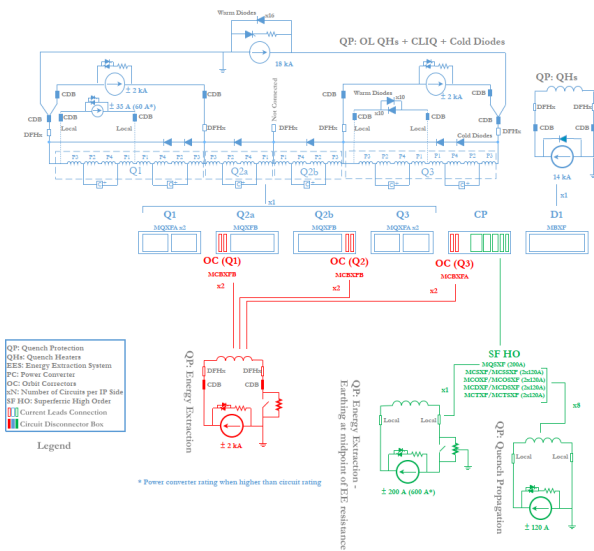

Figure 1: IT String circuit layout.

CIRCUIT PROTECTION

The IT String magnet and circuit protection scheme will mimic that of the HL-LHC. One of the main goals of the IT String test stand is to verify the efficiency of the protection system and verify the adequacy of the defined working principles for the magnet circuits.

The protection schemes include three types of hardware: energy extraction (EE) systems, quench protection with coil heating, and bypass diodes. The three types are combined as a function of each circuit's characteristics and requirements. In particular, the latter two are applied to the quadrupoles' high-current, low- β circuit.

One of the most innovative protection systems are the Coupling Loss Induced Quench (CLIQ) discharge units, which, directly connected to the magnet's conductors, allow for rapid heating of the whole coils in case of a quench. This novel system is combined with the more conventional method of protection where Quench Heater (QH) strips integrated into the magnet coils are used to enforce a more uniform dissipation of energy along the entire coil.

In the main quadrupole circuit, if any superconducting element were to quench (magnet, SC Link, CL, bus bar), the quench protection system is simultaneously activated

String area. This configuration implied the ad-hoc construction of a metallic structure in an already dense area.

INTEGRATION OF THE IT STRING

The integration of the IT String test stand in a 3-D model is shown in Fig. 2. It allows one to design and validate the infrastructures (e.g. metallic platform for the power converters) and services (e.g. cabling path), as well as position the equipment and detect any installation issues.

The equipment and control hardware of the IT String is named using functional positions (i.e. the position slot name), following the general CERN naming conventions. These unique names are used in the process diagram, cabling and layout databases, service requests, equipment documentation, and even control signals and data logging.

The validation Program of the IT String will be orchestrated from a new control room which will offer the same functionalities as the LHC control room.

The crews in the IT String control room will also validate the software that will be used for the hardware commissioning of the HL-LHC.

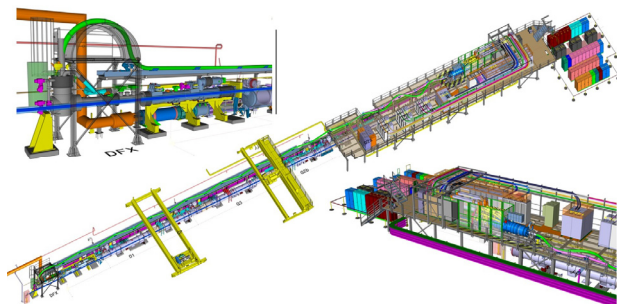

Figure 2: The IT String Integration into SM18. Details of the cold and warm powering are shown.

HANDLING AND INSTALLATION

Equipment handling in a surface building should be less difficult than in a tunnel. Nevertheless, the complex geometries and weights of the systems pose real challenges during installation. Cryo-magnets with lengths up to 11 m and weights up to 21 t will require the use of several handling tools such as overhead cranes, electrical tow tractors and a Rocla machine. The SC Link, another challenging item, with a total length of 72.5 m and a weight of 35 kg/m will be handled using two overhead cranes simultaneously. Its installation will be performed on a narrow platform, shaping 1.5 m radius waves.

PERSONNEL SAFETY

Safety-related aspects for IT String personnel are grouped in three categories: A. Safety compliance at a conceptual and design level for each equipment; B. Safety during construction and commissioning; C. Safety during operation and test program execution. Within each category, a specific methodology for the assessment of the risks and the identification of applicable mitigatory actions is defined. IT String safety applies the regulatory framework for safety within CERN [7].

For deliverables that the HL-LHC and IT String have in common, such as cryo-magnets and power converters, the safety assessment process of the HL-LHC will be applied [8].

For deliverables specific to the IT String, such as the cryogenic distribution line or the metallic structure, a dedicated IT String safety process will apply.

THE STRING VALIDATION PROGRAM

Each individual component, as well as the cryogenic system, will be tested before their installation into the IT String. Once the different components are interconnected, their collective behaviour will be validated and checked in relation to expected performance.

The main objective of the cryogenic tests is to obtain information on transient effects. The typical Electrical Quality Assurance (EIQ) [9] tests will be performed at the specified voltage levels and conditions for each circuit, allowing the adaptation of procedures for the LHC.

The powering and protection tests will form a major part of the IT String validation program and intend to validate the performance of the different components when working together as a system.

Specific tests will be performed to check the performance of the powering and protection systems. These will include tests on crosstalk between the different circuits and their protection systems. Simulating failure scenarios of a subset of the quench protection, while ensuring the proper protection of the circuits, is also considered.

SCHEDULE

The IT String is planned to be ready for cooling down in Q1 of 2023, and to be operational until the end of 2024. The installation has started with the preparation of the zone and the cryogenic system.

It will be followed by the metallic structure and services installation later in 2021. The project is on time, respecting the schedule agreed to at the 2019 HL-LHC Cost and Schedule Review.

CONCLUSION

The IT String is a major, strategic validation step prior to the operation of the LHC in Run 4, foreseen to start in 2027. The installation of the IT String has started, and is advancing according to schedule.

The IT String will test the HL-LHC IT circuits in conditions that either cannot be tested within the components acceptance and characterization program, or depend on the response of the integrated system. It is a test stand for the integration and installation procedures, as well as for the aspects related to the HL-LHC Hardware Commissioning.

REFERENCES

- [1] O. Bruning *et al.*, "High-Luminosity Large Hadron Collider (HL-LHC): Technical design report", CERN, Geneva, Switzerland, Rep. CERN-2020-010, Oct. 2020.

- [2] A. Perin, M. Sisti, S. Claudet, R. van Weelderren, M. Bajko, and F. Dhalla, “The Cryogenic System and Planned Cryogenic Tests For the Future High Luminosity LHC IT Magnet String”, *IEEE Trans. Appl. Supercond.*, vol. 29, pp. 1-4, Aug. 2019, doi:10.1109/TASC.2019.2905080
- [3] A. Herty *et al.*, “HL-LHC Full Remote Allignment Study”, *10th Int. Particle Accelerator Conf. (IPAC'19)*, Melbourne, Australia, May 2019.
doi:10.18429/JACoW-IPAC2019-THPGW057
- [4] P. Faugeras, “Assembly and Commissioning of the LHC Test String”, in *Proc. 16th Particle Accelerator Conf. (PAC'95)*, Dallas, TX, USA, May 1995 pp. 1288-1292, vol. 2, doi:10.1109/PAC.1995.505201
- [5] R. Saban *et al.*, “The preparation of the cryomagnets and the assembly of the LHC test String 2”, in *Proc. 19th Particle Accelerator Conf. (PAC'01)*, Chicago, IL, USA, Jun. 2001, pp. 3433-3435, doi:10.1109/PAC.2001.988135
- [6] M. Bajko *et al.*, “Upgrade of the CERN Superconducting Magnet Test Facility”, *IEEE Trans. Appl. Supercond.*, vol. 27, pp. 1-7, Jun. 2017. doi:10.1109/TASC.2016.2635119
- [7] The CERN Safety Policy,
<https://hse.cern/content/cern-safety-policy>
- [8] T. Otto *et al.*, “High-Luminosity Large Hadron Collider (HL-LHC): Technical design report. Chapter 19 - Safety”, CERN, Geneva, Switzerland, Rep. CERN-2020-010, Oct. 2020.
- [9] S. Russenschuck *et al.*, “Electrical Quality Assurance of the Superconducting Circuits during LHC Machine Assembly”, in *Proc. 11th European Particle Accelerator Conf. (EPAC'08)*, Genoa, Italy, Jun. 2008, paper WEPD016, pp. 2440-2442.