

# DESIGN OF THE ELECTRON ION COLLIDER ELECTRON STORAGE RING SRF CAVITY\*

J. Guo<sup>†</sup>, E. Daly, J. Henry, J. Matalevich, G.-T. Park, R. A. Rimmer, H. Wang, S. Wang  
JLAB, Newport News, VA, USA  
D. Holmes, K.S. Smith, W. Xu, A. Zaltsman, BNL, Upton, NY, USA

## Abstract

The Electron Ion Collider (EIC) under construction at Brookhaven National Laboratory is a high luminosity collider as the next major research facility for the nuclear physics community. Among the numerous RF subsystems in the EIC, the electron storage ring (ESR) fundamental RF cavities system is one of the most challenging. This system will handle a high beam current of up to 2.5 A and replenish up to 10 MW of beam power losses from synchrotron radiation (SR) and high-order modes (HOM). Variable coupling is required in the cavities due to the wide range of required total RF voltage and beam current combinations. In this paper, we will present the status of the design and future plans.

## EIC ESR CAVITY DESIGN

EIC ESR is a high current electron storage ring required to operate at various beam energy (5-18GeV) and beam current (0.23-2.5A average, with one abort gap) [1, 2]. Up to 10 MW of beam power will be provided by 17-18 SRF elliptical cavities of 591 MHz, installed in single phase. The required total cavity voltage and beam current ratio for different operation energies results in the wide range of cavity Qext (factor of ~15) if optimal coupling/detuning is desired. Even if we allow some reflected RF power for the low energy operations when extra RF power is available, a factor of 6-10 variation in the Qext is still needed for the conventional operation with all cavities in the same focusing phase.

One possibility is to operate some cavities in reversed or defocusing phase (RPO). For low energy operations, this configuration can increase the single cavity voltage while keeping the vector sum of voltage the same. Transient beamloading induced by the abort gap for low energy/high current operations can also be mitigated, in combination of a low R/Q design. This concept has been demonstrated at SuperKEKB [3], although long term operation risks need to be studied further. With RPO, it's possible to operate the ESR cavities at fixed Qext of  $\sim 3.5 \times 10^5$ , as shown in Table 1. We design the cavity with two coax fundamental power couplers (FPCs) using pringle shaped tips and nominal Qext of  $3.5 \times 10^5$  per cavity, and use external stub tuners to adjust Qext as needed.

The baseline of the cryomodule design contains a single symmetric cavity, with beampipes tapered to 75 mm radius to match the largest available gate valve possible to fit in the space available for the ESR. Two single-cavity cryomodules will be arranged in one straight between two

quadrupole magnets. The possibility to integrate two cavities in a single cryomodule is still under study, which may provide further space and cost savings.

The ESR cavity started with a symmetric design by F. Marhasuser, which is currently the baseline in the EIC CDR [1]. Recently we proposed an asymmetric design. On one side of the beampipe it has the same 137 mm radius as the symmetric design and tapers to 75 mm, and a 75 mm radius beampipe on the other side without tapering. Figure 1 compares the geometry of the two designs. The asymmetric design has similar figure of merits as the symmetric design, as shown in Table 2. The opened up 137 mm radius beampipe helps to lower the fundamental mode R/Q as well as to damp HOMs in both designs. However, the asymmetric design is obviously more compact longitudinally; it also provides more room for the coupler, which will determine the transverse size of the cryomodule.

Each ESR cavity will use two beamline absorbers (BLAs) to damp the HOM. The BLA is assumed to be a cylindrical warm SiC absorber SC35 from CoorsTek, using the shrink-fit fabrication technique, similar to the BLA used by APS-Upgrade but in a larger radius [4, 5]. In the asymmetric design, the 75 mm radius BLA is about half the length of the 137 mm BLA and provides similar or better attenuation. Figure 2 shows the CST model of an asymmetric version of the cavity with FPCs include the doorknob transitions, Qext tuning stubs, and BLAs.

The maximum voltage of each ESR cavity is 4 MV, and the gradient is 15.8 MV/m, which is reasonable for a high current SRF cavity.

Table 1: Estimate of ESR Cavity Power and Qext for Different Operation Cases, Assuming 18 Cavities in Total

Beam energy		18GeV	10GeV	5GeV
Beam current (A, exc gap)		0.271	2.841	2.841
Beam current (A, average)		0.25	2.616	2.616
Beam power/cav (kW)		501.3	597	189.8
V total (MV)		61.5	21.7	9.84
All	Vcav (MV)	3.42	1.21	0.55
	Qext per cav	3.2E5	3.3E4	2.4E5
Focus- ing	Pfwd/FPC, kW	311.7	373.1	392.7
	Vcav (MV)		3.73	3.9
Focus Cav	Qext		3.5E5	3.5E5
	Pfwd/FPC(kW)		373.8	161.8
RPO, Defocus Cav	Vcav (MV)		3.9	3.65
	Qext		3.5E5	3.5E5
	Pfwd/FPC, kW		373.1	151.6
	# of def cav		6	8

Margins added for beam current (higher than nominal)  
Beam power includes SR and HOM losses

\* Authored by Jefferson Science Associates, LLC under U.S. DOE Contract No. DE-AC05-06OR23177, with additional support from U.S. DOE Award Number DE-SC-0019287

<sup>†</sup>jguo@jlab.org

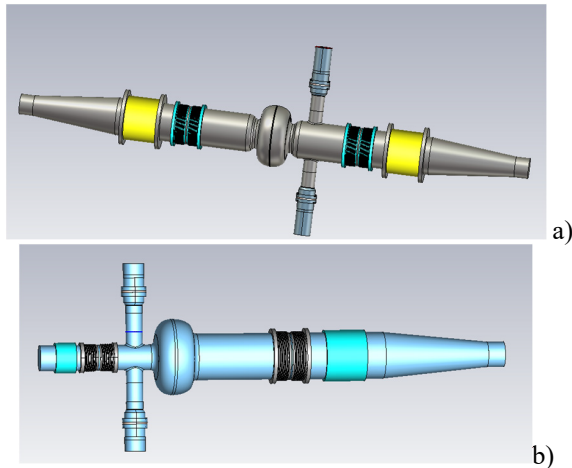

Figure 1: ESR cavity; a) symmetric, b) asymmetric.

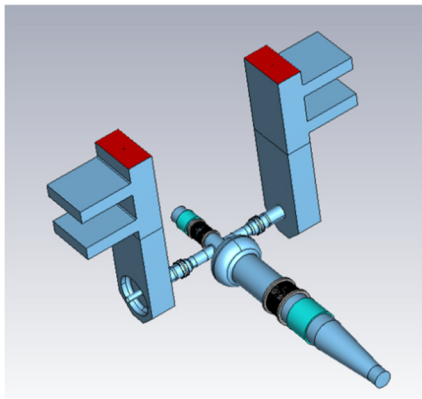

Figure 2: ESR cavity with BLA, FPC and Qext tuning stub, asymmetric design.

Table 2: Basic Parameters of the ESR Cavity Designs

Parameters	Sym	Asym
R/Q (Circ. Def) ( $\Omega$ )	37	38
Epk/Eacc	2.13	2.01
Bpk/Eacc (mT/(MV/m))	4.87	4.87
G (Ohm)	293	307
FPC tip penetration (Qext~3.5E5)	1 mm	3 mm
Approximate total length (gate valve to gate valve)	3.75 m	2.8 m

### FPC FIELD WITH BEAM LOADING

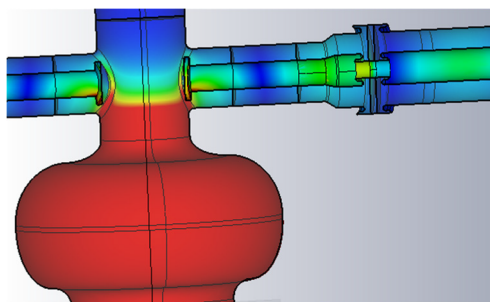

Figure 3: Surface H-field for the case of 600kW beam loading, 800kW RF forward power, and 4MV voltage, without Qext tuning (intrinsic Qext=3.5×10<sup>5</sup>), symmetric.

One FPC of the ESR cavity needs to handle up to 400 kW forward RF power and provides up to 300 kW of beam power, with some reflected power due to gap transient as well as imperfect matching. In case the cavity is operating at the nominal Qext (stub tuners not engaged), the RF field in the FPC is already high, causing heating in the FPC as well as possible breakdown. The situation will be even worse when the stub tuner is engaged, generating a standing wave which could be a few times higher than the forward power.

The FPC field can be simulated with CST frequency domain solver. Beam loading is imitated by a ring on the cavity equator with complex surface impedance. The impedance needs to be adjusted for each simulation case, so that the S11 results from the detuning scan of the cavity match the analytical solution. Figure 3 shows the case that a symmetric cavity operates at 4 MV and 600 kW beam loading, with 200 kW reflected power. Field data are imported into ANSYS for thermal simulation of the warm-to-cold transition. A few more cases with stub tuners need to be added, and a few iterations are needed to optimize the window location and warm-to cold-transition design.

## HOM ANALYSYS

### Monopole HOM Impedance and Power

The total monopole impedance budget threshold of the 18 cavities is set at  $Z \times f = 26 \text{ k}\Omega\text{-GHz}$ , and the goal is 1/10 of that. HOM impedance spectrum of the two designs is studied with CST eigenmode solver as well as long range CST wakefield simulation, and some results are confirmed with SLAC's T3P code. The spectrum is calculated from 200m and 400m wake potential, and extrapolated to wake potential of the infinite length. The results for the asymmetric design are shown in Fig. 4, with the model containing the doorknob with electric boundary. All the modes meet the impedance goal except that some resonances in the FPC are between the goal and the threshold (removed from the eigenmode results in Fig. 4). Most of those FPC modes can be better damped with more realistic boundary, and the rest of them can be optimized by fine tuning the FPC design.

Table 3: Loss Factor (V/pC) of Two ESR Cavity Designs, 20 mm Gaussian Bunch, Excluding the Fundamental Mode

Cases	Sym	Asym
bare cavity, tapered to 75mm	0.128	0.097
Bare cavity with 2 BLAs, tapered	0.276	0.238
FPC shorted, Qext=3.5E5, tapered, no BLA	0.133	0.112
Qext=3.5E5 with doorknob, tapered, 2 BLAs	0.283	0.252

Monopole HOM power is estimated from short range CST simulation. The short range loss factors of the symmetric and asymmetric designs are shown in Table 3, with various FPC and BLA setup. By eliminating one taper, the asymmetric design has better loss factor. We compared

the loss with the impedance spectrum extrapolated from long range wake. The result for the asymmetric case is slightly lower than the short range result, implying that the impedance peaks avoided the major excitation lines.

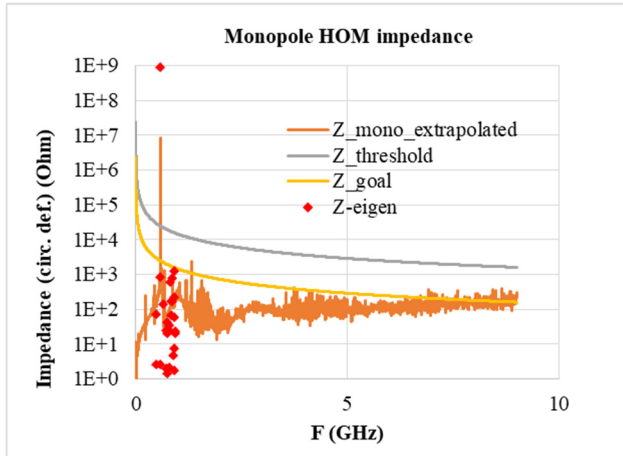

Figure 4: Monopole HOM impedance of the EIC ESR cavity asymmetric design.

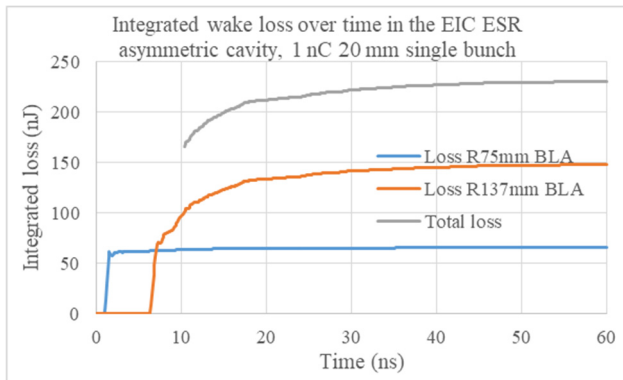

Figure 5: Single bunch HOM loss time integral in BLAs of the asymmetric cavity.

With the 27.6 nC per bunch and 2.5 A beam current, we can estimate that the total HOM power for the 20 mm bunch length in the tapered asymmetric cavity with BLAs and FPCs will be 17.4 kW, using the loss factor from the CST short range wake simulation. The worst case of 7 mm bunch length will be simulated in the future, but the loss is expected to double the number from the case of 20 mm, to around 35 kW.

We also made a CST wake simulation monitoring the power flow into the BLAs and beampipes in the asymmetric cavity, as shown in Fig. 5. The length of the simulation is limited to 60 ns due to storage space usage of the simulation. The total loss in the BLA and beampipes integrated over the 60 ns is about 91% of the HOM loss factor, which is sufficient to estimate the total HOM power going into different destinations. With the 20 mm bunch length, on the cavity's large beampipe side, about 11.1 kW will be absorbed by the BLA, 1.1 kW will leak through the gate valve and mostly absorbed by the BLA of the next cavity; on the cavity's smaller side, 4.9 kW will be absorbed by the BLA, 0.2 kW will leak out to the next cavity or the rest of the storage ring. The total heat

load of the large BLA is only slightly higher than the symmetric cavity case (9.8 kW under the same beam parameters). The 7 mm bunch will increase the large BLA heat load to ~20 kW level. Further optimization of the BLAs is also planned.

### Dipole Impedance

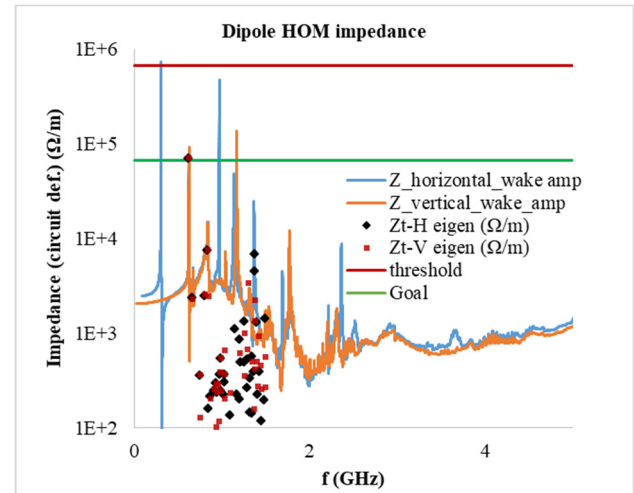

Figure 6: Dipole HOM impedance of the EIC ESR cavity asymmetric design.

Similar to the monopole impedance, we estimated the dipole impedance of the asymmetric cavity with both eigenmode solvers and the long range wakefield solutions, as shown in Fig. 6. The total impedance threshold for all 18 cavities is 12 MΩ/m. We used a simplified model without the doorknobs and the windows in this simulation to reduce the meshing, generating stronger FPC modes, which are also removed manually from the eigenmode results. The realistic boundary should be able to bring down those high impedance FPC modes. There is only one cavity dipole mode close to the impedance goal, and the other cavity dipole modes are all well damped.

## CONCLUSION

We have made extensive simulation studies on the EIC ESR cavities, especially with two versions of designs, one symmetric and one asymmetric. The cavity parameters and HOM study results of both designs so far meet the design requirements. The two designs have similar performance, while the asymmetric design is obviously more compact. A few more tasks such as the multipacting study are still pending before the downselect of the cavity shape, planned to be completed soon. The optimization in the BLAs and FPCs can continue while the prototype cavity body is being fabricated. The option of double cavity cryomodule also needs to be explored.

## REFERENCES

[1] F. Willeke *et al.*, "Electron Ion Collider Conceptual Design Report", 2021, <https://doi.org/10.2172/1765663>  
 [2] C. Montag *et al.*, "Electron-Ion Collider Design Status", presented at IPAC'22, Bangkok, Thailand, Jun. 2022, WEPOPT044, this conference.

- [3] Y. Morita, “Reverse phase operation”, presented at EIC Workshop – Promoting Collaboration on the Electron-Ion Collider, Cockcroft Institute, Oct. 2020, Cockcroft Institute of Accelerator Science and Technology, UK, <https://indico.cern.ch/event/949203/>
- [4] D. Holmes, “R&D Toward High Power Warm SiC Beam Line HOM Absorbers”, presented at TTC 2020, Feb. 2020, CERN. <https://indico.cern.ch/event/817780/>
- [5] S. Kim, “HOM Damping in Superconducting Harmonic Cavity for Advanced Photon Source Upgrade”, presented at HOMSC’16, Warnemünde, Germany, 2016. <https://indico.cern.ch/event/465683/>