

3.5MEV INJECTOR FOR AN INDUCTION LINAC

Zhang Kaizhi, Wen Long, Li Hong, Li Jin, Dai Zhiyong, Zhang Wenwei, Xie Yutong, Wang Meng, Wang Huacen, Dai Guangsen, Zhang Linwen, Deng Jianjun, Ding Bonan
Institute of Fluid Physics, CAEP, P.O.Box 919-106, Mianyang, P.R.China

Abstract

High quality injected beam is fundamental for an induction linac. A 3.5MeV injector to produce 3.0 kA high brightness electron beam is introduced in this paper. 7 induction accelerating cavities on the side of cathode and 5 cavities on the side of anode are added together to provide 3.5 MV high voltage pulse across the diode, with pulse length of 90ns. The electron beam source is a 7cm diameter velvet cathode. 1.4m diameter radial insulators with liquid resistor are used to keep cathode stem and anode stem along center axis of the injector, and oppress flashover electric field at the same time. Solenoid coils are placed inside cathode stalk and anode stalk which work together with Solenoid coils in accelerating cavities to lead emitted beam transport through anode pipe. Measured extracted beam parameters are described in the end of the paper.

Key word: LIA, injector, diode, radial insulator, accelerating cavity

about 20kV/cm. And emitted electrons are evenly distributed all over the emission surface.

Foil diode is widely used before because it is beneficial for field distribution across diode. But collision between particles and foil will degrade beam quality, and the life time limitation prevent foil from spreading further as well.

The simulation using PIC code demonstrates that under proper magnetic field, more than 3.75kA beam current can be extracted, and the normalized emittance is 0.15cm-rad.

1 INTRODUCTION

Linear induction accelerator is widely used in hydrodynamic radiograph. As for this application the beam spot size focused on the target is of high importance. The final spot size depends heavily on beam quality. It is one of the most important measures taken to achieve high quality beam to build a high performance injector.

Because beam quality is heavily affected by beam breakup instability and corkscrew during transportation, it is the main objective to extract high brightness beam with energy spread and centroid offset as small as possible from the newly built injector.

2 CATHODE AND ANODE

The geometry of diode is the vital point of injector. Electric field must be controlled under the threshold of emission of metallic material, and at the same time, the field around the emission material, for example, velvet, should be evenly distributed.

Simulation is used to optimize the diode geometry to keep cathode and anode from breakdown. Figure 1 shows the schematics of cathode and anode, and the calculated electric field distribution. The maximum field strength on the cathode surface is 276kV/cm, and the field on velvet surface is 226kV/cm when operating at 3.5MV.

Velvet is adopted as the best field emission material. Its electric field threshold for electron emission is lower,

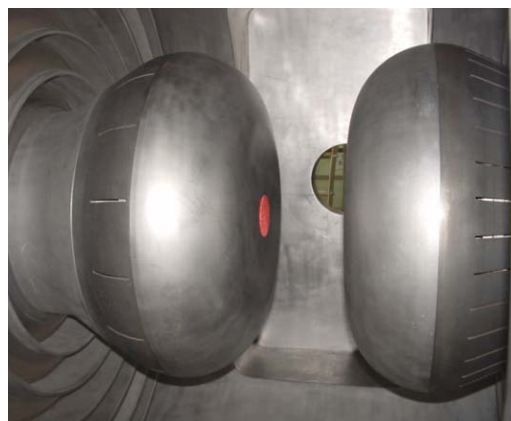

Figure 1: Schematics of cathode and anode, and the calculated electric field distribution

3 ACCELERATING CAVITY

12 induction accelerating cavities, 7 on the side of cathode, 5 of anode side, each provide a 300kV high voltage pulse are stacked together by cathode stem and anode pipe respectively. 13 ferrite toroids are installed inside each cavity. Flux swing is about 0.7T of the ferrite toroid with OD=800, ID=510 and thickness of 23mm. Large diameter toroids are demanded in case of breakdown between cathode stem and inner wall of cavities. In addition, accelerating gap is optimized and enlarged to 38cm, and cavities are filled with oil. Simulation result shows that the maximum field stress is less than 200kV/cm on the outer surface of cavity pipe, just 201kV/cm along cathode stem.



Figure 2: 3D view of induction accelerating cavity for injector

4 MAGNETIC FIELD

Magnetic field distribution among injector includes two parts, diode magnets and those inside accelerating cavities. Three diode magnets are placed inside cathode, anode and anode pipe respectively. And the magnets conducting cords go out through cathode stem and anode pipe, wires inside anode pipe are distributed circumference symmetrically not to introduce additional transverse magnetic field. During the period of injector installation, magnetic field distribution was measured and dipolar coils was used to try to correct solenoid error field. Laser tracker was used to align the whole system, and the offset among magnetic axis, beam axis and geometry axis was controlled less than 0.07mm, and tilt angle of cathode surface from the above axis less than 1mrad.

5 RADIAL INSULATOR

Radial insulators help to align cathode and anode in the center of injector while operated at high voltage of 3.5MV, at the same time, they must separate vacuum, liquid and oil effectively from each other. It is the core of the theory that liquid resistor linearly distributed helps to homogenize electric field along radius. The best of models ever simulated shows a highest field of 54kV/cm at tripoint under 3.5MV. Before formally fabrication, a smaller insulator worked at lower voltage is manufactured to verify the theory and simulation.

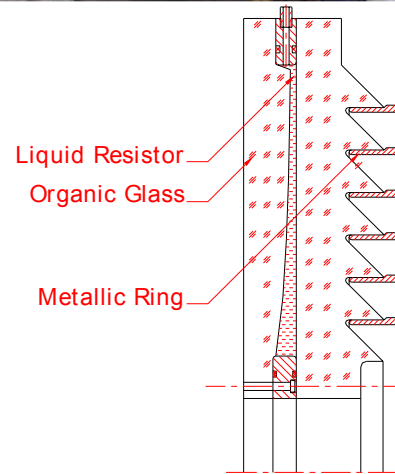

Figure 3: Photo(upper) and schematics(lower) of Radial Insulator

6 CONCLUSION

The pulsed power system includes mainly 2 Marx generators and 12 blumleins, it generates about 250kV, 90ns high voltage pulses to the accelerating cavities. Changing the value of matching resistor 3.2 MV high voltage was loaded across the gap of 16cm between cathode and anode. 74ns, more than 3kA beam current was extracted from the end of injector with beam centroid displacement of 0.7mm from the magnetic axis. Almost all beam current was transported to the end of the accelerator, but beam breakup instability came into being.

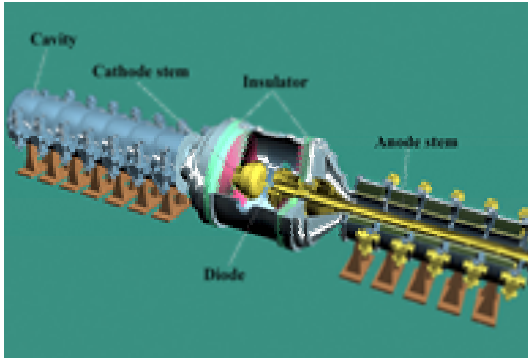

Figure 4: Overview of 3.5MeV injector

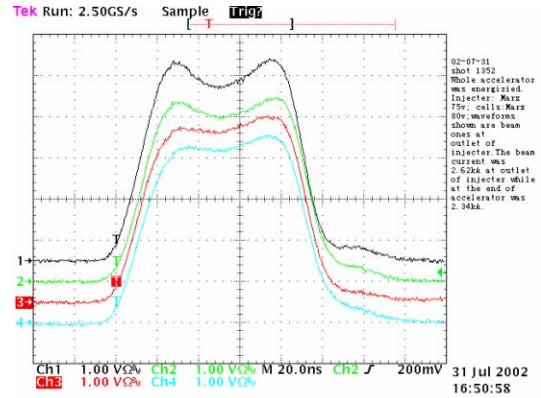

Figure 6: Extracted beam current from injector

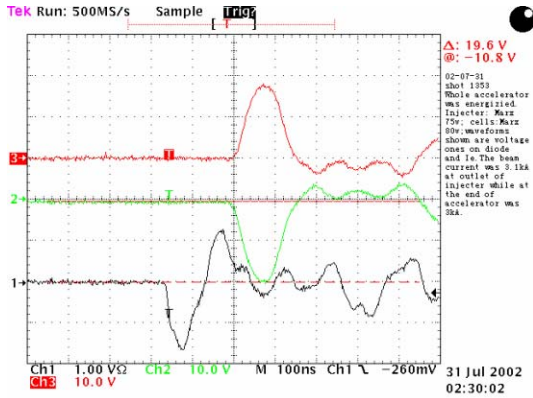

Figure 5: Anode voltage(upper) and cathode voltage(middle)

7 ACKNOWLEDGEMENTS

From the beginning of this project, Prof. Shi Jinshui and colleagues from Accelerator Lab. Join our team and give us much good advice. Prof. Wang wendou and his group undertook most of the simulation. Prof. Cao Kefeng and his group provide us power source for solenoid. The author gratefully acknowledges help from persons mentioned above.

8 REFERENCE

- [1] G.J.Caporaso and A.G.Cole, "High Current Electron Transport", AIP 1992
- [2] M.G.Mazarakis, etc, "Low Emittance Immersed and Non-Immersed Foilless Diodes for High Current Electron Linacs", PAC'89, P1002
- [3] Ding Bonan, "Advices on Injector", internal material, 1999